

191144, Санкт-Петербург, ул. Моисеенко, д. 5
Телефон: (812) 335-21-16, (812) 335-21-17
Почта: mail@mirposudy.ru
www.mirposudy.ru

GESAMTPROGRAMM

Complete Range

2013 | 2014

PROFESSIONAL
HOTEL
EQUIPMENT



Inhalt

contents



Besteck flatware

I

Besteckmodelle
flatware collections

Besteck Ergänzungsteile
neutral serving pieces

Kinderbestecke
childrens flatware



Table Top table top

II

Getränke heiß & kalt
beverages hot & cold

- KaffeeKultur / coffeeCulture
- Tee & Kaffee / tea & coffee
- Wein/ wine
- Wasser / water

Servieren
serving

- Platzteller & Clochen / plate trays & covers
- Serviergeräte / serving utensils
- Tisch Accessoires / table accessories
- Körbe & Schalen / baskets & bowls

Tischdekoration
table decoration

- Kerzen & Leuchter / candles & lamps
- Vasen / vases
- Tischnummern / table numbers

Würzen
spice it up

- Mühlen & Menagen / grinding & condiment sets



Buffet buffet

III

combiNation Buffet
combiNation buffet

Warmhalten
keeping warm

- Chafing Dishes Induktion / chafing dishes induction
- Chafing Dishes / chafing dishes
- Chafing Dish Zubehör / chafing dish accessory
- Coffee Urns / coffee urns

Dosieren
portioning

- Dispenser / dispenser

Präsentieren
presenting

- Étagères / étagères
- Platten & Tablett / platters & trays
- Finger food / finger food
- Körbe & Schalen / baskets & bowls



Bar & smoke
bar & smoke

IV

Besteck
flatware

Table Top
table top

Buffet
buffet



Trends & Themen
trends & topics

V

Hotelzimmer
rooms

Apartments
apartments

Glas
glass

Servierwagen
serving trolleys

Küche
kitchen

Kaffeemaschinen
coffeemachines

Bar & smoke
bar & smoke

Trends & Themen
trends & topics



Pflege & Reparatur
maintenance & repair

VI

Material
material

Aufarbeitung & Reparatur
refurbishment & repair

Pflege-Tipps
maintenance

Pflegemittel
cleaning aids

Pflege & Reparatur
maintenance & repair

A - Z

A-Z

Gesamt-Inhaltsverzeichnis
alphabetical index

VII

Kompetenz Expertise

Bereits seit 1853 beschäftigt sich die Württembergische Metallwarenfabrik AG mit Produkten rund um die gepflegte Gastlichkeit. Diese langjährige Erfahrung ist sicherlich ein Faktor für unsere Fachkompetenz und Basis für den renommierten Namen, den die WMF weltweit in der Gastronomie genießt.

Auch in Zukunft werden wir alles daran setzen, diesen guten Ruf zu bestätigen und weiter auszubauen. Kundenfreundliche Komplettlösungen aus einer Hand bieten zu können ist eine unserer größten Stärken. So ist es uns möglich, auch den individuellen Anforderungen Ihres Betriebes gerecht zu werden.

Dieser Katalog zeigt Ihnen die Bandbreite unserer WMF Hotel Produktpalette. Produkte, gestaltet von international anerkannten Designern, hergestellt mit modernsten umweltfreundlichen Fertigungstechniken in denkbar bester Qualität.

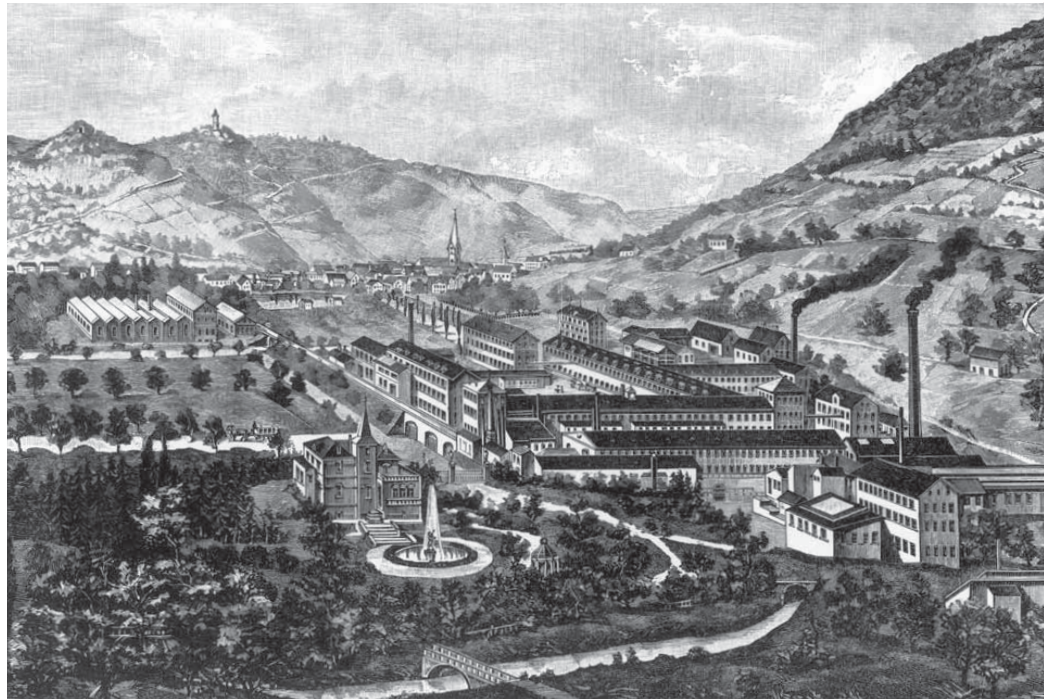

Since as long ago as 1853 Württembergische Metallwarenfabrik AG has been involved in the manufacture of products covering all aspects of hospitality. This long experience is without doubt a factor in our specialised expertise and is the basis for the excellent reputation that WMF enjoys in the hotel and catering industry throughout the world.

Our objective for the future is to maintain and enhance our good name. WMF Hotel can provide customer-orientated all-in-one solutions from a single source to satisfy the particular requirements of your business.

This combined catalogue shows you the range of our varied WMF Hotel product line. Products created by internationally renowned designers and produced by the very latest in environmentally-friendly manufacturing methods of the highest possible quality.





Karl Wagenfeld



Ron Arad photographed by John Davis



Zaha Hadid photographed by Steve Double

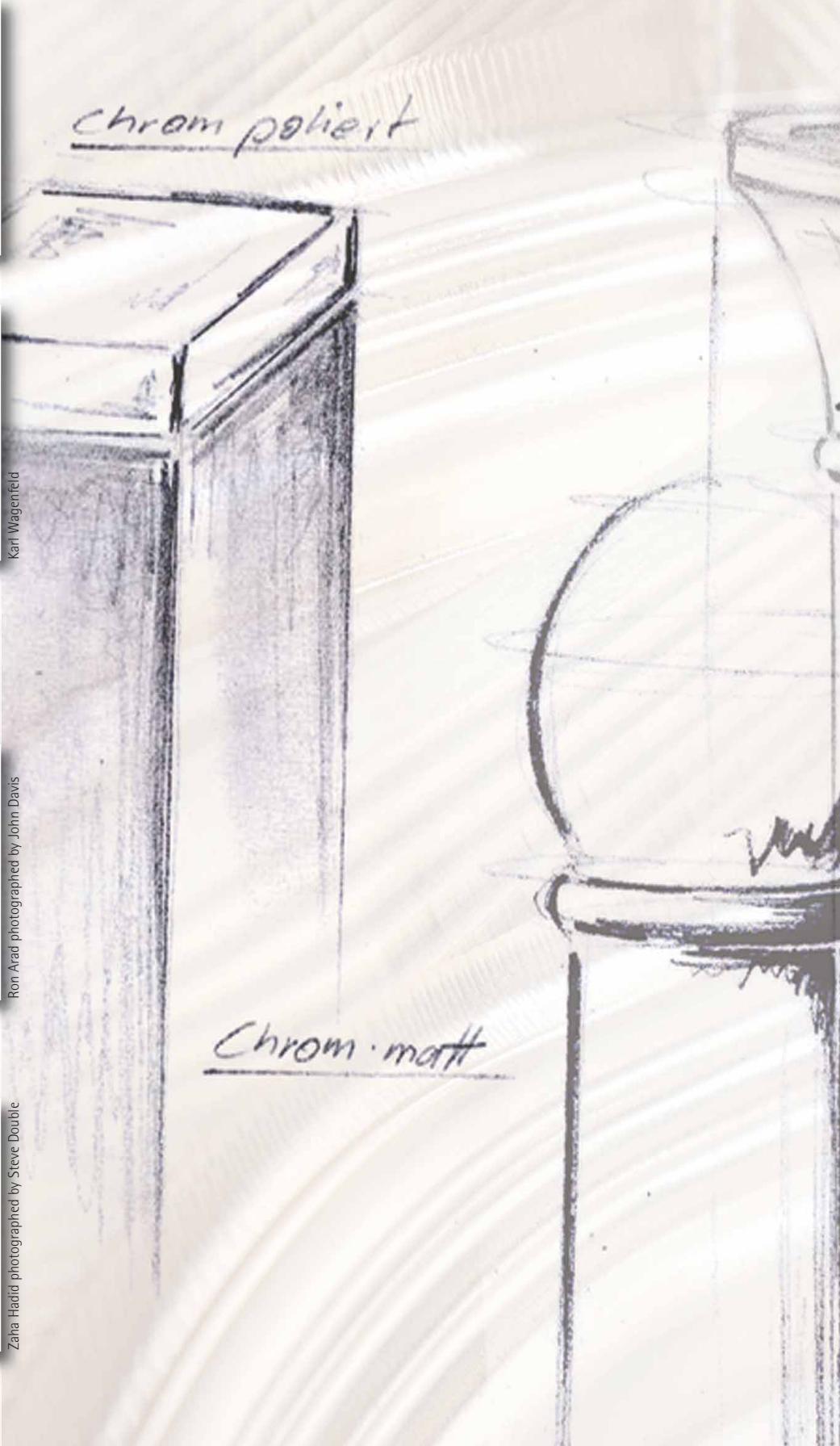



Innovation Innovation

Wir investieren in Ideen.
Eine Innovation ist die Verwirklichung einer guten Idee. Wir stellen im Interesse unserer Kunden die Ressourcen in Forschung, Entwicklung, Design und Management bereit, die aus Gedanken Entwürfe und aus Entwürfen neue Produkte entstehen lassen.

We invest in ideas.
An innovation is the realization of a good idea. In the interest of our customers, we provide the resources in research, development, design and management that it takes to turn ideas into designs and designs into new products.

Entwicklung Development

Ein Maßstab bei der Entwicklung unserer Produkte ist Ihr harter gastronomischer Alltag. Dieser stellt an Verarbeitung und Anwenderfreundlichkeit die höchsten Anforderungen.

One criterion in the development of our products is the stress of daily catering use. That means workmanship and user-friendliness have to meet the highest standards.



Stilbewusstsein Sense of style

Das Zubereiten, Anrichten und Servieren von Speisen und Getränken ist eine Kunst. Wir unterstützen Sie dabei mit einer Bandbreite von Produkten, die ihresgleichen sucht.

The preparation, presentation and serving of food and drink is an art. We can assist you with an unrivalled range of products.

Produktvielfalt Product diversity

Ob stilvoll, modern, jung oder sachlich ... bei WMF Hotel finden Sie genau die Produkte, die Ihrem persönlichen Einrichtungsstil gerecht werden.

Stylish, modern, young or down-to-earth ... in WMF Hotel you will find just the right products to suit your individual equipment style.



Qualität quality



Perfekte Versilberung /
perfectly silver-plating



Silberauflage in
Hotelqualität /
hotel grade silver
plating



Individualisierung,
z. B. durch Gravur oder
Stempelung /
customisation, e.g. by
engraving or stamping



Gabelzinken innen
bearbeitet /
inside-machined
fork prongs



Ausgewogene Balance
jedes Besteckteils /
each piece of cutlery
perfectly balanced



Klingen der Hohlheftmesser
aus geschmiedetem
Spezial-Klingenstahl /
blades of hollow handle
knives made from
special blade steel



WMF Hotel ist nach DIN EN ISO 9001 - 2008 zertifiziert und garantiert Ihnen ein Höchstmaß an Zuverlässigkeit und Kundenorientierung /
 WMF Hotel is certified in accordance with DIN EN ISO 9001 - 2008. This guarantees the highest level of reliability and customer satisfaction



Cromargan®: Edelstahl Rostfrei 18/10 - korrosionsbeständig, unempfindlich /
 Cromargan®: stainless steel 18/10 - corrosion-resistant, non-sensitive



Spülmaschinenfest / dishwasher safe



Gastronomiegerechte Materialstärke / correct material thickness for the catering industry



Tropffreie Kannen / non drip jugs



Kondenswasserrücklauf / condensation return



Hitzeisolierte Griffe / insulated handles



Hitzebeständige Griffe / heat resistant handles

bis/up to 600°C/1112°F



Reparatur-Service & Aufarbeiten / repair service & refurbishment



BESTECK flatware



Besteckmodelle
flatware collections

Besteck Ergänzungsteile
neutral serving pieces

Kinderbestecke
childrens flatware

BESTECK FLATWARE

MODELLE COLLECTIONS

NEU | NEW



TELOS 1800 ■ ■



EPOS 1600



CASINO 9000



SIGNUM 1900



UNIC 5300



NORDIC 7200



SOLID 7900



CONTOUR 0200



CLUB 4700



BISTRO 0400



BAGUETTE 0100



BASE 2300



CLASSIC 3400



RESIDENCE 4800



METROPOLITAN 5400



GASTRO 0800



BAROCK 3200



FLAIR 1100



MONDIAL 6200



GASTROLINE 0000

- 54.7201.6030
- 54.7201.6040

Menuelöffel

230 mm/9 in.
table spoon
cuiller de table
cuchara mesa
cucchiaio tavola



- 54.7235.6030
- 54.7235.6040

Fischgabel

203 mm/8 in.
fish fork
fourchette à poisson
tenedor pescado
forchetta pesce



- 54.7202.6030
- 54.7202.6040

Menuegabel

228 mm/9 in.
table fork
fourchette de table
tenedor mesa
forchetta tavola



- 54.7236.6030
- 54.7236.6040

Fischmesser

226 mm/9 in.
fish knife
couteau à poisson
cuchillo pescado
coltello pesce



- 54.7203.6039
- 54.7203.6049

Menuemesser**

246 mm/9 3/4 in.
table knife**
couteau de table**
cuchillo mesa**
coltello tavola cutinato**



- 54.7240.6030
- 54.7240.6040

Austerngabel

149 mm/5 7/8 in.
oyster fork
fourchette à huîtres
tenedor ostras
forchetta per ostriche



- 54.7204.6030
- 54.7204.6040

Vorspeisenlöffel

212 mm/8 1/2 in.
dessert spoon
cuiller à dessert
cuchara postre
cucchiaio frutta



- 54.7264.6030
- 54.7264.6040

Kuchengabel

164 mm/6 1/2 in.
cake fork
fourchette à gâteau
tenedor lunch
forchetta per dolce



- 54.7205.6030
- 54.7205.6040

Vorspeisengabel

210 mm/8 1/4 in.
dessert fork
fourchette à dessert
tenedor postre
forchetta frutta



- 54.7266.6039
- 54.7266.6049

**Brot- /
Buttermesser****

170 mm/6 3/4 in.
bread/butter knife**
couteau de table**
cuchillo mesa**
coltello per dolce**



- 54.7206.6039
- 54.7206.6049

**Vorspeisen-
messer****

226 mm/9 in.
dessert knife**
cuiller à dessert**
cuchara postre**
cucchiaio frutta**



- 54.7272.6030
- 54.7272.6040

Limolöffel

220 mm/8 3/4 in.
iced tea spoon
cuiller à soda
cuchara refresco
cucchiaio bibita



- 54.7207.6030
- 54.7207.6040

Kaffeelöffel

140 mm/5 1/2 in.
tea/coffee spoon
cuiller à café
cuchara café
cucchiaio caffè/té



- 54.7278.6039
- 54.7278.6049

Steakmesser**

248 mm/9 3/4 in.
steak knife**
couteau à steak**
cuchillo steak**
coltello da bistecca**



- 54.7209.6030
- 54.7209.6040

**Espresso- /
Mokkalöffel**

110 mm/4 1/4 in.
demi-tasse spoon
cuiller à mocca
cuchara moca
cucchiaio moca



- 54.7289.6030
- 54.7289.6040

Tassenlöffel

181 mm/7 1/4 in.
round bowl soup spoon
cuiller à bouillon
cuchara sopa
cucchiaio da brodo



- 54.7210.6030
- 54.7210.6040

**Vorspeisen- /
Dessertlöffel**

163 mm/6 1/2 in.
coffee/tea spoon, large
cuiller à café/thé, grande
cuchara à café/té, grande
cucchiaio caffè/té, grande



- 54.7211.6030
- 54.7211.6040

Gourmetlöffel

203 mm/8 in.
gourmet spoon
cuiller à sauce
cuchara salsa
cucchiaio gourmet



■ perfekte Versilberung /
perfectly silverplated

■ Cromargan®, poliert /
stainless 18/10, polished

** Klingenstahl mit Wellenschliff /
monobloc with serrated edge



NORDIC 7200

■ 54 7200 6030

perfekt versilbert
perfectly silverplated
chromage parfait
plateado perfecto
perfetta placcatura in argento

■ 54 7200 6040

Cromargan®, poliert
Cromargan®, polished
Cromargan®, poli
Cromargan®, pulido
Cromargan®, lucido

■ 54.1601.6030

■ 54.1601.6040



Menuelöffel

213 mm/8½ in.
table spoon
cuiller de table
cuchara mesa
cucchiaio tavola

■ 54.1602.6030

■ 54.1602.6040



Menuegabel

211 mm/8¼ in.
table fork
fourchette de table
tenedor mesa
forchetta tavola

■ 54.1603.6037

■ 54.1603.6047



Menuemesser*

236 mm/9¼ in.
table knife*
couteau de table*
cuchillo mesa*
coltello tavola cutinato*

■ 54.1603.6039

■ 54.1603.6049



Menuemesser***

236 mm/9¼ in.
table knife***
couteau de table***
cuchillo mesa***
coltello tavola cutinato***

■ 54.1604.6030

■ 54.1604.6040



Vorspeisenlöffel

196 mm/7¾ in.
dessert spoon
cuiller à dessert
cuchara postre
cucchiaio frutta

■ 54.1605.6030

■ 54.1605.6040



Vorspeisengabel

195 mm/7¾ in.
dessert fork
fourchette à dessert
tenedor postre
forchetta frutta

■ 54.1606.6037

■ 54.1606.6047



**Vorspeisen-
messer***

217 mm/8½ in.
dessert knife*
couteau à dessert*
cuchillo postre*
coltello frutta*

■ 54.1606.6039

■ 54.1606.6049



**Vorspeisen-
messer*****

217 mm/8½ in.
dessert knife***
couteau à dessert***
cuchillo postre***
coltello frutta***

■ 54.1607.6030

■ 54.1607.6040



Kaffeelöffel

136 mm/5¼ in.
tea/coffee spoon
cuiller à café
cuchara café
cucchiaio caffè/té

■ 54.1609.6030

■ 54.1609.6040



**Espresso- /
Mokkalöffel**

108 mm/4¼ in.
demi-tasse spoon
cuiller à moca
cuchara moca
cucchiaio moca

■ 54.1610.6030

■ 54.1610.6040



**Vorspeisen- /
Dessertlöffel**

156 mm/6¼ in.
coffee/tea spoon, large
cuiller à café/thé, grande
cuchara à café/té, grande
cucchiaio caffè/té, grande

■ 54.1611.6030

■ 54.1611.6040



Gourmetlöffel

196 mm/7¾ in.
gourmet spoon
cuiller à sauce
cuchara gourmet
cucchiaio gourmet

■ 54.1635.6030

■ 54.1635.6040



Fischgabel

190 mm/7½ in.
fish fork
fourchette à poisson
tenedor pescado
forchetta pesce

■ 54.1636.6030

■ 54.1636.6040



Fischmesser

214 mm/8½ in.
fish knife
couteau à poisson
cuchillo pescado
coltello pesce

■ 54.1640.6030

■ 54.1640.6040



Austerngabel

149 mm/5¾ in.
oyster fork
fourchette à huîtres
tenedor ostras
forchetta per ostriche

■ 54.1664.6030

■ 54.1664.6040



Kuchengabel

157 mm/6¼ in.
cake fork
fourchette à gâteau
tenedor lunch
forchetta per dolce

■ 54.1666.6039

■ 54.1666.6049



**Brot- /
Buttermesser****

170 mm/6¾ in.
bread/butter knife**
couteau de table**
cuchillo lunch**
coltello per dolce**

■ 54.1672.6030

■ 54.1672.6040



Limolöffel

220 mm/8½ in.
iced tea spoon
cuiller à soda
cuchara refresco
cucchiaio bibita

■ 54.1678.6039

■ 54.1678.6049



Steakmesser**

239 mm/9½ in.
steak knife**
couteau à steak**
cuchillo steak**
coltello da bistecca**

■ 54.1689.6030

■ 54.1689.6040



Tassenlöffel

174 mm/6¾ in.
round bowl soup spoon
cuiller à bouillon
cuchara sopa
cucchiaio da brodo

■ perfekte Versilberung /
perfectly silverplated

■ Cromargan®, poliert /
stainless 18/10, polished

* Hohlheft mit Wellenschliff,
steht auch auf Klinge /
hollow-handle with serrated edge,
standing on blade optional

** Klingenstahl mit Wellenschliff /
monobloc with serrated edge

*** Klingenstahl mit Wellenschliff,
steht auch auf Klinge /
monobloc with serrated edge,
standing on blade optional



EPOS 1600

■ 54 1600 6030

perfekt versilbert
 perfectly silverplated
 chromage parfait
 plateado perfecto
 perfetta placcatura in argento

■ 54 1600 6040

Cromargan®, poliert
 Cromargan®, polished
 Cromargan®, poli
 Cromargan®, pulido
 Cromargan®, lucido

■ 54.9001.6030

■ 54.9001.6040

**Menuelöffel**210 mm/8¹/₄ in.
table spoon
cuiller de table
cuchara mesa
cucchiaio tavola

■ 54.9035.6030

■ 54.9035.6040

**Fischgabel**179 mm/7 in.
fish fork
fourchette à poisson
tenedor pescado
forchetta pesce

■ 54.9002.6030

■ 54.9002.6040

**Menuegabel**208 mm/8¹/₄ in.
table fork
fourchette de table
tenedor mesa
forchetta tavola

■ 54.9036.6030

■ 54.9036.6040

**Fischmesser**201 mm/8 in.
fish knife
couteau à poisson
cuchillo pescado
coltello pesce

■ 54.9003.6039

■ 54.9003.6049

**Menuemesser****234 mm/9¹/₄ in.
table knife**
couteau de table**
cuchillo mesa**
coltello tavola cutinato**

■ 54.9040.6030

■ 54.9040.6040

**Austerngabel**149 mm/5⁷/₈ in.
oyster fork
fourchette à huîtres
tenedor ostras
forchetta per ostriche

■ 54.9004.6030

■ 54.9004.6040

**Vorspeisenlöffel**190 mm/7¹/₂ in.
dessert spoon
cuiller à dessert
cuchara postre
cucchiaio frutta

■ 54.9064.6030

■ 54.9064.6040

**Kuchengabel**158 mm/6¹/₄ in.
cake fork
fourchette à gâteau
tenedor lunch
forchetta per dolce

■ 54.9005.6030

■ 54.9005.6040

**Vorspeisengabel**188 mm/7¹/₂ in.
dessert fork
fourchette à dessert
tenedor postre
forchetta frutta

■ 54.9066.6039

■ 54.9066.6049

**Brot- /
Buttermesser****170 mm/6³/₄ in.
bread/butter knife**
couteau de table**
cuchillo lunch**
coltello per dolce**

■ 54.9006.6039

■ 54.9006.6049

**Vorspeisen-
messer****212 mm/8¹/₄ in.
dessert knife**
couteau à dessert**
cuchillo postre**
coltello frutta**

■ 54.9072.6030

■ 54.9072.6040

**Limolöffel**220 mm/8³/₄ in.
iced tea spoon
cuiller à soda
cuchara refresco
cucchiaio bibita

■ 54.9007.6030

■ 54.9007.6040

**Kaffeelöffel**134 mm/5¹/₄ in.
tea/coffee spoon
cuiller à café
cuchara café
cucchiaio caffè/té

■ 54.9078.6039

■ 54.9078.6049

**Steakmesser****234 mm/9¹/₄ in.
steak knife**
couteau à steak**
cuchillo steak**
coltello da bistecca**

■ 54.9009.6030

■ 54.9009.6040

**Espresso- /
Mokkalöffel**108 mm/4¹/₄ in.
demi-tasse spoon
cuiller à moca
cuchara moca
cucchiaio moca

■ 54.9089.6030

■ 54.9089.6040

**Tassenlöffel**168 mm/6¹/₂ in.
round bowl soup spoon
cuiller à bouillon
cuchara sopa
cucchiaio da brodo

■ 54.9010.6030

■ 54.9010.6040

**Vorspeisen- /
Dessertlöffel**159 mm/6¹/₄ in.
coffee/tea spoon, large
cuiller à café/thé, grande
cuchara à café/té, grande
cucchiaio caffè/té, grande

■ 54.9011.6030

■ 54.9011.6040

**Gourmetlöffel**190 mm/7¹/₂ in.
gourmet spoon
cuiller à sauce
cuchara gourmet
cucchiaio gourmet■ perfekte Versilberung /
perfectly silverplated■ Cromargan®, poliert /
stainless 18/10, polished** Klingenstahl mit Wellenschliff /
monobloc with serrated edge



CASINO 9000

■ 54 9000 6030

perfekt versilbert
perfectly silverplated
chromage parfait
plateado perfecto
perfetta placcatura in argento

■ 54 9000 6040

Cromargan®, poliert
Cromargan®, polished
Cromargan®, poli
Cromargan®, pulido
Cromargan®, lucido

■ 10.7901.6060
■ 12.7901.6040

Menuelöffel

212 mm/8¹/₄ in.
table spoon
cuiller de table
cuchara mesa
cucchiaio tavola



■ 10.7902.6060
■ 12.7902.6040

Menuegabel

210 mm/8¹/₄ in.
table fork
fourchette de table
tenedor mesa
forchetta tavola



■ 10.7903.6067
■ 12.7903.6047

Menuemesser*

246 mm/9³/₄ in.
table knife*
couteau de table*
cuchillo mesa*
coltello tavola cutinato*



■ 10.7903.6069
■ 12.7903.6049

Menuemesser**

239 mm/9¹/₂ in.
table knife**
couteau de table**
cuchillo mesa**
coltello tavola cutinato**



■ 10.7910.6060
■ 12.7910.6040

**Vorspeisen- /
Dessertlöffel**

159 mm/6¹/₄ in.
coffee/tea spoon, large
cuiller à café/thé, grande
cuchara à café/té, grande
cucchiaio caffè/té, grande



■ 10.7911.6060
■ 12.7911.6040

Gourmetlöffel

190 mm/7¹/₂ in.
gourmet spoon
cuiller à sauce
cuchara gourmet
cucchiaio gourmet



■ 10.7935.6062
■ 12.7935.6042

Fischgabel

188 mm/7¹/₂ in.
fish fork
fourchette à poisson
tenedor pescado
forchetta pesce



■ 10.7935.6063
■ 12.7935.6043

Fischmesser

209 mm/8¹/₄ in.
fish knife
couteau à poisson
cuchillo pescado
coltello pesce



■ 10.7904.6060
■ 12.7904.6040

Vorspeisenlöffel

190 mm/7¹/₂ in.
dessert spoon
cuiller à dessert
cuchara postre
cucchiaio frutta



■ 10.7940.6060
■ 12.7940.6040

Austerngabel

149 mm/5³/₄ in.
oyster fork
fourchette à huîtres
tenedor ostras
forchetta per ostriche



■ 10.7905.6060
■ 12.7905.6040

Vorspeisengabel

188 mm/7¹/₂ in.
dessert fork
fourchette à dessert
tenedor postre
forchetta frutta



■ 10.7964.6060
■ 12.7964.6040

Kuchengabel

160 mm/6¹/₄ in.
cake fork
fourchette à gâteau
tenedor lunch
forchetta per dolce



■ 10.7906.6067
■ 12.7906.6047

**Vorspeisen-
messer***

220 mm/8³/₄ in.
dessert knife*
couteau à dessert*
cuchillo postre*
coltello frutta*



■ 10.7966.6069
■ 12.7966.6049

**Brot- /
Buttermesser****

170 mm/6²/₄ in.
bread/butter knife**
couteau de table**
cuchillo lunch**
coltello per dolce**



■ 10.7906.6069
■ 12.7906.6049

**Vorspeisen-
messer****

214 mm/8¹/₂ in.
dessert knife**
couteau à dessert**
cuchillo postre**
coltello frutta**



■ 10.7972.6060
■ 12.7972.6040

Limolöffel

220 mm/8³/₄ in.
iced tea spoon
cuiller à soda
cuchara refresco
cucchiaio bibita



■ 10.7907.6060
■ 12.7907.6040

Kaffeelöffel

136 mm/5¹/₄ in.
tea/coffee spoon
cuiller à café
cuchara café
cucchiaio caffè/té



■ 10.7978.6069
■ 12.7978.6049

Steakmesser**

235 mm/9¹/₄ in.
steak knife**
couteau à steak**
cuchillo steak**
coltello da bistecca**



■ 10.7909.6060
■ 12.7909.6040

**Espresso- /
Mokkalöffel**

108 mm/4¹/₄ in.
demi-tasse spoon
cuiller à moca
cuchara moca
cucchiaio moca



■ 10.7989.6060
■ 12.7989.6040

Tassenlöffel

170 mm/6²/₄ in.
round bowl soup spoon
cuiller à bouillon
cuchara sopa
cucchiaio da brodo



■ perfekte Versilberung /
perfectly silverplated

■ Cromargan®, poliert /
stainless 18/10, polished

* Hohlheft mit Wellenschliff /
hollow-handled with serrated edge

** Klingenstahl mit Wellenschliff /
monobloc with serrated edge



SOLID 7900

■ 10 7900 6060

perfekt versilbert
perfectly silverplated
chromage parfait
plateado perfecto
perfetta placcatura in argento

■ 12 7900 6040

Cromargan®, poliert
Cromargan®, polished
Cromargan®, poli
Cromargan®, pulido
Cromargan®, lucido

■ 01.0401.6060
 ■ 11.0401.6040
Menuelöffel
 203 mm/8 in.
 table spoon
 cuiller de table
 cuchara mesa
 cucchiaio tavola



■ 01.0402.6060
 ■ 11.0402.6040
Menuegabel
 201 mm/8 in.
 table fork
 fourchette de table
 tenedor mesa
 forchetta tavola



■ 01.0403.6067
 ■ 11.0403.6047
Menuemesser*
 230 mm/9 in.
 table knife*
 couteau de table*
 cuchillo mesa*
 coltello tavola cutinato*



■ 01.0403.6069
 ■ 11.0403.6049
Menuemesser**
 227 mm/9 in.
 table knife**
 couteau de table**
 cuchillo mesa**
 coltello tavola cutinato**



■ 01.0410.6060
 ■ 11.0410.6040
**Vorspeisen- /
 Dessertlöffel**
 156 mm/6 1/4 in.
 coffee/tea spoon, large
 cuiller à café/thé, grande
 cuchara à café/té, grande
 cucchiaio caffè/té grande



■ 01.0411.6060
 ■ 11.0411.6040
Gourmetlöffel
 190 mm/7 1/2 in.
 gourmet spoon
 cuiller à sauce
 cuchara gourmet
 cucchiaio gourmet



■ 01.0435.6062
 ■ 11.0435.6042
Fischgabel
 183 mm/7 1/4 in.
 fish fork
 fourchette à poisson
 tenedor pescado
 forchetta pesce



■ 01.0435.6063
 ■ 11.0435.6043
Fischmesser
 206 mm/8 in.
 fish knife
 couteau à poisson
 cuchillo pescado
 coltello pesce



■ 01.0404.6060
 ■ 11.0404.6040
Vorspeisenlöffel
 183 mm/7 1/4 in.
 dessert spoon
 cuiller à dessert
 cuchara postre
 cucchiaio frutta



■ 01.0440.6060
 ■ 11.0440.6040
Austerngabel
 145 mm/5 3/4 in.
 oyster fork
 fourchette à huîtres
 tenedor ostras
 forchetta per ostriche



■ 01.0405.6060
 ■ 11.0405.6040
Vorspeisengabel
 181 mm/7 in.
 dessert fork
 fourchette à dessert
 tenedor postre
 forchetta frutta



■ 01.0464.6060
 ■ 11.0464.6040
Kuchengabel
 157 mm/6 1/4 in.
 cake fork
 fourchette à gâteau
 tenedor lunch
 forchetta per dolce



■ 01.0406.6067
 ■ 11.0406.6047
**Vorspeisen-
 messer***
 209 mm/8 1/4 in.
 dessert knife*
 couteau à dessert*
 cuchillo postre*
 coltello frutta*



■ 01.0466.6069
 ■ 11.0466.6049
**Brot- /
 Buttermesser****
 170 mm/6 3/4 in.
 bread/butter knife**
 couteau de table**
 cuchillo lunch**
 coltello per dolce**



■ 01.0406.6069
 ■ 11.0406.6049
**Vorspeisen-
 messer****
 205 mm/8 in.
 dessert knife**
 couteau à dessert**
 cuchillo postre**
 coltello frutta**



■ 01.0472.6060
 ■ 11.0472.6040
Limolöffel
 220 mm/8 3/4 in.
 iced tea spoon
 cuiller à soda
 cuchara refresco
 cucchiaio bibita



■ 01.0407.6060
 ■ 11.0407.6040
Kaffeelöffel
 132 mm/5 1/4 in.
 tea/coffee spoon
 cuiller à café
 cuchara café
 cucchiaio caffè/té



■ 01.0478.6069
 ■ 11.0478.6049
Steakmesser**
 230 mm/9 in.
 steak knife**
 couteau à steak**
 cuchillo steak**
 coltello da bistecca**



■ 01.0409.6060
 ■ 11.0409.6040
**Espresso- /
 Mokkalöffel**
 108 mm/4 1/4 in.
 demi-tasse spoon
 cuiller à moca
 cuchara moca
 cucchiaio moca



■ 01.0489.6060
 ■ 11.0489.6040
Tassenlöffel
 166 mm/6 1/2 in.
 round bowl soup spoon
 cuiller à bouillon
 cuchara sopa
 cucchiaio da brodo



■ perfekte Versilberung /
 perfectly silverplated

■ Cromargan®, poliert /
 stainless 18/10, polished

* Hohlheft mit Wellenschliff /
 hollow-handled with serrated edge

** Klingenstahl mit Wellenschliff /
 monobloc with serrated edge



BISTRO 0400

■ 01 0400 6060

perfekt versilbert
 perfectly silverplated
 chromage parfait
 plateado perfecto
 perfetta placcatura in argento

■ 11 0400 6040

Cromargan®, poliert
 Cromargan®, polished
 Cromargan®, poli
 Cromargan®, pulido
 Cromargan®, lucido

■ 10.1901.6060

■ 12.1901.6040



Menuelöffel

212 mm/8 1/4 in.
table spoon
cuiller de table
cuchara mesa
cucchiaio tavola

■ 10.1902.6060

■ 12.1902.6040



Menuegabel

210 mm/8 1/4 in.
table fork
fourchette de table
tenedor mesa
forchetta tavola

■ 10.1903.6067

■ 12.1903.6047



Menuemesser*

239 mm/9 1/2 in.
table knife*
couteau de table*
cuchillo mesa*
coltello tavola cutinato*

■ 10.1903.6069

■ 12.1903.6049



Menuemesser**

238 mm/9 1/2 in.
table knife**
couteau de table**
cuchillo mesa**
coltello tavola cutinato**

■ 10.1904.6060

■ 12.1904.6040



Vorspeisenlöffel

190 mm/7 1/2 in.
dessert spoon
cuiller à dessert
cuchara postre
cucchiaio frutta

■ 10.1905.6060

■ 12.1905.6040



Vorspeisengabel

188 mm/7 1/2 in.
dessert fork
fourchette à dessert
tenedor postre
forchetta frutta

■ 10.1906.6067

■ 12.1906.6047



Vorspeisenmesser*

214 mm/8 1/2 in.
dessert knife*
couteau à dessert*
cuchillo postre*
coltello frutta*

■ 10.1906.6069

■ 12.1906.6049



Vorspeisenmesser**

213 mm/8 1/2 in.
dessert knife**
couteau à dessert**
cuchillo postre**
coltello frutta**

■ 10.1907.6060

■ 12.1907.6040



Kaffeelöffel

136 mm/5 1/2 in.
tea/coffee spoon
cuiller à café
cuchara café
cucchiaio caffè/té

■ 10.1909.6060

■ 12.1909.6040



Espresso- / Mokkalöffel

108 mm/4 1/4 in.
demi-tasse spoon
cuiller à mocca
cuchara moca
cucchiaio moca

■ 10.1910.6060

■ 12.1910.6040



Vorspeisen- / Dessertlöffel

156 mm/6 1/4 in.
coffee/tea spoon, large
cuiller à café/thé grande
cuchara à café/té, grande
cucchiaio caffè/té, grande

■ 10.1911.6060

■ 12.1911.6040



Gourmetlöffel

190 mm/7 1/2 in.
gourmet spoon
cuiller à sauce
cuchara gourmet
cucchiaio gourmet

■ 10.1916.6060

■ 12.1916.6040



Gemüselöffel

237 mm/9 1/4 in.
vegetable serving spoon
cuiller à légumes
cucharón legumbres
cucchiaione servire

■ 10.1935.6062

■ 12.1935.6042



Fischgabel

184 mm/7 1/4 in.
fish fork
fourchette à poisson
tenedor pescado
forchetta pesce

■ 10.1935.6063

■ 12.1935.6043



Fischmesser

206 mm/8 in.
fish knife
couteau à poisson
cuchillo pescado
coltello pesce

■ 10.1940.6060

■ 12.1940.6040



Austergabel

149 mm/5 7/8 in.
oyster fork
fourchette à huîtres
tenedor ostras
forchetta per ostriche

■ 10.1964.6060

■ 12.1964.6040



Kuchengabel

157 mm/6 1/4 in.
cake fork
fourchette à gâteau
tenedor lunch
forchetta per dolce

■ 10.1966.6069

■ 12.1966.6049



Brot- / Buttermesser**

170 mm/6 5/8 in.
bread/butter knife**
couteau de table**
cuchillo mesa**
coltello per dolce**

■ 10.1972.6060

■ 12.1972.6040



Limolöffel

220 mm/8 3/4 in.
iced tea spoon
cuiller à soda
cuchara refresco
cucchiaio bibita

■ 10.1978.6069

■ 12.1978.6049



Steakmesser**

239 mm/9 1/2 in.
steak knife**
couteau à steak**
cuchillo steak**
coltello da bistecca**

■ 10.1989.6060

■ 12.1989.6040



Tassenlöffel

170 mm/6 3/4 in.
round bowl soup spoon
cuiller à bouillon
cuchara sopa
cucchiaio da brodo

■ perfekte Versilberung / perfectly silverplated

■ Cromargan®, poliert / stainless 18/10, polished

* Hohlheft mit Wellenschliff / hollow-handled with serrated edge

** Klingenstahl mit Wellenschliff / monobloc with serrated edge



SIGNUM 1900

■ 10 1900 6060

perfekt versilbert
perfectly silverplated
chromage parfait
plateado perfecto
perfetta placcatura in argento

■ 12 1900 6040

Cromargan®, poliert
Cromargan®, polished
Cromargan®, poli
Cromargan®, pulido
Cromargan®, lucido

■ 10.5301.6060
■ 12.5301.6040

Menuelöffel
215 mm/8½ in.
table spoon
cuiller de table
cuchara mesa
cucchiaio tavola



■ 10.5302.6060
■ 12.5302.6040

Menuegabel
214 mm/8¼ in.
table fork
fourchette de table
tenedor mesa
forchetta tavola



■ 10.5303.6061
■ 12.5303.6041

Menuemesser***
237 mm/9½ in.
table knife***
couteau de table***
cuchillo mesa***
coltello tavola***



■ 10.5303.6067
■ 12.5303.6047

Menuemesser*
233 mm/9¼ in.
table knife*
couteau de table*
cuchillo mesa*
coltello tavola cutinato*



■ 10.5303.6069
■ 12.5303.6049

Menuemesser**
236 mm/9¼ in.
table knife**
couteau de table**
cuchillo mesa**
coltello tavola**



■ 10.5304.6060
■ 12.5304.6040

Vorspeisenlöffel
196 mm/7¾ in.
dessert spoon
cuiller à dessert
cuchara postre
cucchiaio frutta



■ 10.5305.6060
■ 12.5305.6040

Vorspeisengabel
195 mm/7¾ in.
dessert fork
fourchette à dessert
tenedor postre
forchetta frutta



■ 10.5306.6061
■ 12.5306.6041

Vorspeisenmesser****
216 mm/8½ in.
dessert knife***
couteau à dessert***
cuchillo postre***
coltello frutta***



■ 10.5306.6067
■ 12.5306.6047

Vorspeisenmesser*
212 mm/8¼ in.
dessert knife*
couteau à dessert*
cuchillo postre*
coltello frutta*



■ 10.5306.6069
■ 12.5306.6049

Vorspeisenmesser**
215 mm/8½ in.
dessert knife**
couteau à dessert**
cuchillo postre**
coltello frutta**



■ 10.5307.6060
■ 12.5307.6040

Kaffeelöffel
136 mm/5¼ in.
tea/coffee spoon
cuiller à café
cuchara café
cucchiaio caffè/té



■ 10.5309.6060
■ 12.5309.6040

Espresso- / Mokkalöffel
108 mm/4¼ in.
demi-tasse spoon
cuiller à moca
cuchara moca
cucchiaio moca



■ 10.5310.6060
■ 12.5310.6040

Vorspeisen- / Dessertlöffel
156 mm/6¼ in.
coffee/tea spoon, large
cuiller à café/thé, grande
cuchara à café/té, grande
cucchiaio caffè/té, grande



■ 10.5311.6060
■ 12.5311.6040

Gourmetlöffel
196 mm/7¾ in.
gourmet spoon
cuiller à sauce
cuchara gourmet
cucchiaio gourmet



■ 10.5335.6061
■ 12.5335.6041

Fischmesser****
216 mm/8½ in.
fish knife****
couteau à poisson****
cuchillo pescado****
coltello pesce****



■ 10.5335.6062
■ 12.5335.6042

Fischgabel
190 mm/7½ in.
fish fork
fourchette à poisson
tenedor pescado
forchetta pesce



■ 10.5335.6063
■ 12.5335.6043

Fischmesser
215 mm/8½ in.
fish knife
couteau à poisson
cuchillo pescado
coltello pesce



■ 10.5340.6060
■ 12.5340.6040

Austerngabel
149 mm/5¾ in.
oyster fork
fourchette à huîtres
tenedor ostras
forchetta per ostriche



■ 10.5364.6060
■ 12.5364.6040

Kuchengabel
157 mm/6¼ in.
cake fork
fourchette à gâteau
tenedor lunch
forchetta per dolce



■ 10.5366.6061
■ 12.5366.6041

Brot- / Buttermesser***
170 mm/6¾ in.
bread/butter knife***
couteau de table***
cuchillo lunch***
coltello per dolce***



■ 10.5366.6069
■ 12.5366.6049

Brot- / Buttermesser**
170 mm/6¾ in.
bread/butter knife**
couteau de table**
cuchillo mesa**
coltello per dolce**



■ 10.5372.6060
■ 12.5372.6040

Limolöffel
220 mm/8½ in.
iced tea spoon
cuiller à soda
cuchara refresco
cucchiaio bibita



■ 10.5378.6069
■ 12.5378.6049

Steakmesser**
239 mm/9½ in.
steak knife**
couteau à steak**
cuchillo steak**
coltello da bistecca**



■ 10.5389.6060
■ 12.5389.6040

Tassenlöffel
174 mm/6¾ in.
round bowl soup spoon
cuiller à bouillon
cuchara sopa
cucchiaio da brodo



- perfekte Versilberung / perfectly silverplated
- Cromargan®, poliert / stainless 18/10, polished
- * Hohlheft mit Wellenschliff / hollow-handled with serrated edge
- ** Klingenstahl mit Wellenschliff / monobloc with serrated edge
- *** Klingenstahl mit Wellenschliff, steht auch auf Klinge / monobloc with serrated edge, standing on blade optional
- **** Klingenstahl, steht auf Klinge / monobloc, standing on blade optional



UNIC 5300

■ 10 5300 6060

perfekt versilbert
 perfectly silverplated
 chromage parfait
 plateado perfecto
 perfetta placcatura in argento

■ 12 5300 6040

Cromargan®, poliert
 Cromargan®, polished
 Cromargan®, poli
 Cromargan®, pulido
 Cromargan®, lucido

■ 01.3401.6060
■ 11.3401.6040

Menuelöffel

204 mm/8 in.
table spoon
cuiller de table
cuchara mesa
cucchiaio tavola



■ 01.3402.6060
■ 11.3402.6040

Menuegabel

201 mm/8 in.
table fork
fourchette de table
tenedor mesa
forchetta tavola



■ 01.3403.6067
■ 11.3403.6047

Menuemesser*

232 mm/9 in.
table knife*
couteau de table*
cuchillo mesa*
coltello tavola cutinato*



■ 01.3403.6069
■ 11.3403.6049

Menuemesser**

230 mm/9 in.
table knife**
couteau de table**
cuchillo mesa**
coltello tavola cutinato**



■ 01.3404.6060
■ 11.3404.6040

Vorspeisenlöffel

183 mm/7 1/4 in.
dessert spoon
cuiller à dessert
cuchara postre
cucchiaio frutta



■ 01.3405.6060
■ 11.3405.6040

Vorspeisengabel

181 mm/7 in.
dessert fork
fourchette à dessert
tenedor postre
forchetta frutta



■ 01.3406.6067
■ 11.3406.6047

**Vorspeisen-
messer***

208 mm/8 1/4 in.
dessert knife*
couteau à dessert*
cuchillo postre*
coltello frutta*



■ 01.3406.6069
■ 11.3406.6049

**Vorspeisen-
messer****

208 mm/8 1/4 in.
dessert knife**
couteau à dessert**
cuchillo postre**
coltello frutta**



■ 01.3407.6060
■ 11.3407.6040

Kaffeelöffel

132 mm/5 1/4 in.
tea/coffee spoon
cuiller à café
cuchara café
cucchiaio caffè/té



■ 01.3409.6060
■ 11.3409.6040

**Espresso- /
Mokkalöffel**

107 mm/4 1/4 in.
demi-tasse spoon
cuiller à mocca
cuchara moca
cucchiaio moca



■ 01.3410.6060
■ 11.3410.6040

**Vorspeisen- /
Dessertlöffel**

156 mm/6 1/4 in.
coffee/tea spoon, large
cuiller à café/té, grande
cuchara à café/té, grande
cucchiaio caffè/té, grande



■ 01.3411.6060
■ 11.3411.6040

Gourmetlöffel

186 mm/7 1/4 in.
gourmet spoon
cuiller à sauce
cuchara gourmet
cucchiaio gourmet



■ 01.3435.6062
■ 11.3435.6042

Fischgabel

183 mm/7 1/4 in.
fish fork
fourchette à poisson
tenedor pescado
forchetta pesce



■ 01.3435.6063
■ 11.3435.6043

Fischmesser

206 mm/8 in.
fish knife
couteau à poisson
cuchillo pescado
coltello pesce



■ 01.3440.6060
■ 11.3440.6040

Austerngabel

145 mm/5 3/4 in.
oyster fork
fourchette à huîtres
tenedor ostras
forchetta per ostriche



■ 01.3464.6060
■ 11.3464.6040

Kuchengabel

157 mm/6 1/4 in.
cake fork
fourchette à gâteau
tenedor lunch
forchetta per dolce



■ 01.3466.6069
■ 11.3466.6049

**Brot- /
Buttermesser****

170 mm/6 2/4 in.
bread/butter knife**
couteau de table**
cuchillo lunch**
coltello per dolce**



■ 01.3472.6060
■ 11.3472.6040

Limolöffel

220 mm/8 3/4 in.
iced tea spoon
cuiller à soda
cuchara refresco
cucchiaio bibita



■ 11.3478.6049

Steakmesser**

226 mm/9 in.
steak knife**
couteau à steak**
cuchillo steak**
coltello da bistecca**



■ 01.3489.6060
■ 11.3489.6040

Tassenlöffel

165 mm/6 1/2 in.
round bowl soup spoon
cuiller à bouillon
cuchara sopa
cucchiaio da brodo



■ perfekte Versilberung /
perfectly silverplated

■ Cromargan®, poliert /
stainless 18/10, polished

* Hohlheft mit Wellenschliff /
hollow-handled with serrated edge

** Klingenstahl mit Wellenschliff /
monobloc with serrated edge



CLASSIC 3400

■ 01 3400 6060

perfekt versilbert
perfectly silverplated
chromage parfait
plateado perfecto
perfetta placcatura in argento

■ 11 3400 6040

Cromargan®, poliert
Cromargan®, polished
Cromargan®, poli
Cromargan®, pulido
Cromargan®, lucido

■ 01.3201.6061
■ 11.3201.6041

Menüelöffel

198 mm/7⁷/₈ in.
table spoon
cuiller de table
cuchara mesa
cucchiaio tavola



■ 01.3202.6061
■ 11.3202.6041

Menuegabel

198 mm/7⁷/₈ in.
table fork
fourchette de table
tenedor mesa
forchetta tavola



■ 11.3202.6042

Menuegabel, lang

210 mm/8¹/₂ in.
table fork, long
fourchette de table, longue
tenedor mesa, de largo
forchetta tavola, lungo



■ 01.3203.6067
■ 11.3203.6047

Menuemesser*

218 mm/8⁵/₈ in.
table knife*
couteau de table*
cuchillo mesa*
coltello tavola cutinato*



■ 01.3203.6069
■ 11.3203.6049

Menuemesser**

217 mm/8⁵/₈ in.
table knife**
couteau de table**
cuchillo mesa**
coltello tavola cutinato**



■ 11.3233.6049

Menuemesser, lang**

240 mm/9¹/₂ in.
table knife**, long
couteau de table**, long
cuchillo mesa**, de largo
coltello tavola**, lungo



■ 01.3204.6061
■ 11.3204.6041

Vorspeisenlöffel

188 mm/7¹/₂ in.
dessert spoon
cuiller à dessert
cuchara postre
cucchiaio frutta



■ 01.3205.6061
■ 11.3205.6041

Vorspeisengabel

186 mm/7³/₈ in.
dessert fork
fourchette à dessert
tenedor postre
forchetta frutta



■ 01.3206.6067
■ 11.3206.6047

Vorspeisenmesser*

205 mm/8 in.
dessert knife*
couteau à dessert*
cuchillo postre*
coltello frutta*



■ 01.3206.6069
■ 11.3206.6049

Vorspeisenmesser**

198 mm/7⁷/₈ in.
dessert knife**
couteau à dessert**
cuchillo postre**
coltello frutta**



■ 01.3207.6061
■ 11.3207.6041

Kaffeelöffel

138 mm/5¹/₂ in.
tea/coffee spoon
cuiller à café
cuchara café
cucchiaio caffè/té



■ 01.3209.6061
■ 11.3209.6041

Espresso- / Mokkalöffel

108 mm/4¹/₄ in.
demi-tasse spoon
cuiller à moca
cuchara moca
cucchiaio moca



■ 01.3210.6061
■ 11.3210.6041

Vorspeisen- / Dessertlöffel

157 mm/6¹/₄ in.
coffee/tea spoon, large
cuiller à café/té, grande
cuchara à café/té, grande
cucchiaio caffè/té, grande



■ 01.3211.6061
■ 11.3211.6041

Gourmetlöffel

188 mm/7¹/₂ in.
gourmet spoon
cuiller à sauce
cuchara gourmet
cucchiaio gourmet



■ 01.3218.6061

Saucenlöffel

175 mm/7 in.
gravy ladle
cuiller à sauce
cazo salsa
mestolino salsa



■ 01.3235.6068

Fischgabel

180 mm/7 in.
fish fork
fourchette à poisson
tenedor pescado
forchetta pesce



■ 11.3235.6048

■ 01.3235.6069

Fischmesser

210 mm/8¹/₄ in.
fish knife
couteau à poisson
cuchillo pescado
coltello pesce



■ 11.3235.6049

■ 01.3264.6061

Kuchengabel

157 mm/6¹/₄ in.
cake fork
fourchette à gâteau
tenedor lunch
forchetta per dolce



■ 11.3264.6041

■ 01.3266.6069

Brot- / Buttermesser**

177 mm/7 in.
bread/butter knife**
couteau de table**
cuchillo lunch**
coltello per dolce**



■ 11.3266.6049

■ 01.3272.6061

Limolöffel

220 mm/8⁵/₈ in.
iced tea spoon
cuiller à soda
cuchara refresco
cucchiaio bibita



■ 11.3272.6041

■ 01.3289.6061
■ 11.3289.6041

Tassenlöffel

167 mm/6⁵/₈ in.
round bowl soup spoon
cuiller à bouillon
cuchara sopa
cucchiaio da brodo



■ perfekte Versilberung / perfectly silverplated

■ Cromargan®, poliert / stainless 18/10, polished

* Hohlheft mit Wellenschliff / hollow-handled with serrated edge

** Klingenstahl mit Wellenschliff / monobloc with serrated edge



BAROCK 3200

■ 01 3200 6061

perfekt versilbert
perfectly silverplated
chromage parfait
plateado perfecto
perfetta placcatura in argento

■ 11 3200 6041

Cromargan®, poliert
Cromargan®, polished
Cromargan®, poli
Cromargan®, pulido
Cromargan®, lucido

- 10.6201.6060 **Menuelöffel**
 12.6201.6040
 203 mm/8 in.
 table spoon
 cuiller de table
 cuchara mesa
 cucchiaio tavola



- 10.6202.6060 **Menuegabel**
 12.6202.6040
 201 mm/8 in.
 table fork
 fourchette de table
 tenedor mesa
 forchetta tavola



- 12.6202.6042 **Menuegabel, lang**
 210 mm/8 1/2 in.
 table fork, long
 fourchette de table, longue
 tenedor mesa, largo
 forchetta tavola, lungo



- 10.6203.6067 **Menuemesser***
 12.6203.6047
 232 mm/9 1/4 in.
 table knife*
 couteau de table*
 cuchillo mesa*
 coltello tavola cutinato*



- 10.6203.6069 **Menuemesser****
 12.6203.6049
 229 mm/9 in.
 table knife**
 couteau de table**
 cuchillo mesa**
 coltello tavola cutinato**



- 12.6233.6049 **Menuemesser**, lang**
 240 mm/9 1/2 in.
 table knife**, long
 couteau de table**, long
 cuchillo mesa**, largo
 coltello tavola**, lungo



- 10.6204.6060 **Vorspeisenlöffel**
 12.6204.6040
 187 mm/7 1/2 in.
 dessert spoon
 cuiller à dessert
 cuchara postre
 cucchiaio frutta



- 10.6205.6060 **Vorspeisengabel**
 12.6205.6040
 185 mm/7 1/4 in.
 dessert fork
 fourchette à dessert
 tenedor postre
 forchetta frutta



- 10.6206.6067 **Vorspeisenmesser***
 12.6206.6047
 213 mm/8 1/2 in.
 dessert knife*
 couteau à dessert*
 cuchillo postre*
 coltello frutta*



- 10.6206.6069 **Vorspeisenmesser****
 12.6206.6049
 213 mm/8 1/2 in.
 dessert knife**
 couteau à dessert**
 cuchillo postre**
 coltello frutta**



- 10.6207.6060 **Kaffeelöffel**
 12.6207.6040
 132 mm/5 1/4 in.
 tea/coffee spoon
 cuiller à café
 cuchara café
 cucchiaio caffè/té



- 10.6209.6060 **Espresso- / Mokkalöffel**
 12.6209.6040
 108 mm/4 1/4 in.
 demi-tasse spoon
 cuiller à moca
 cuchara moca
 cucchiaio moca



- 10.6210.6060 **Vorspeisen- / Dessertlöffel**
 12.6210.6040
 156 mm/6 1/4 in.
 coffee/tea spoon, large
 cuiller à café/té, grande
 cuchara à café/té, grande
 cucchiaio caffè/té, grande



- 10.6211.6060 **Gourmetlöffel**
 12.6211.6040
 186 mm/7 3/8 in.
 gourmet spoon
 cuiller à sauce
 cuchara gourmet
 cucchiaio gourmet



- 12.6216.6040 **Gemüselöffel/ Salatlöffel**
 237 mm/9 1/2 in.
 vegetable serving spoon
 cuiller à légumes
 cucharón legumbres
 cucchiaione servire



- 12.6221.6042 **Salatgabel**
 235 mm/9 1/4 in.
 salad fork
 fourchette à salade
 tenedor ensalada
 forchetta servire



- 10.6235.6062 **Fischgabel**
 12.6235.6042
 183 mm/7 1/4 in.
 fish fork
 fourchette à poisson
 tenedor pescado
 forchetta pesce



- 10.6235.6063 **Fischmesser**
 12.6235.6043
 206 mm/8 in.
 fish knife
 couteau à poisson
 cuchillo pescado
 coltello pesce



- 10.6240.6060 **Austerngabel**
 12.6240.6040
 138 mm/5 1/2 in.
 oyster fork
 fourchette à huîtres
 tenedor ostras
 forchetta per ostriche



- 10.6264.6060 **Kuchengabel**
 12.6264.6040
 157 mm/6 1/4 in.
 cake fork
 fourchette à gâteau
 tenedor lunch
 forchetta per dolce

- 10.6266.6069 **Brot- / Buttermesser****
 12.6266.6049
 170 mm/6 3/4 in.
 bread/butter knife**
 couteau de table**
 cuchillo lunch**
 coltello per dolce**

- 10.6272.6060 **Limolöffel**
 12.6272.6040
 220 mm/8 3/4 in.
 iced tea spoon
 cuiller à soda
 cuchara refresco
 cucchiaio bibita

- 10.6278.6069 **Steakmesser****
 12.6278.6049
 229 mm/9 in.
 steak knife**
 couteau à steak**
 cuchillo steak**
 coltello da bistecca**

- 10.6289.6060 **Tassenlöffel**
 12.6289.6040
 166 mm/6 1/2 in.
 round bowl soup spoon
 cuiller à bouillon
 cuchara sopa
 cucchiaio da brodo



■ perfekte Versilberung / perfectly silverplated
 ■ Cromargan®, poliert / stainless 18/10, polished
 * Hohlheft mit Wellenschliff / hollow-handled with serrated edge
 ** Klingenstahl mit Wellenschliff / monobloc with serrated edge



MONDIAL 6200

■ 10 6200 6060

perfekt versilbert
perfectly silverplated
chromage parfait
plateado perfecto
perfetta placcatura in argento

■ 12 6200 6040

Cromargan®, poliert
Cromargan®, polished
Cromargan®, poli
Cromargan®, pulido
Cromargan®, lucido

■ 01.0101.6060
■ 11.0101.6040

Menuelöffel

211 mm/8¹/₂ in.
table spoon
cuiller de table
cuchara mesa
cucchiaio tavola



■ 01.0102.6060
■ 11.0102.6040

Menuegabel

211 mm/8¹/₂ in.
table fork
fourchette de table
tenedor mesa
forchetta tavola



■ 01.0115.6061
■ 11.0115.6041

Menuelöffel, klein

196 mm/7³/₄ in.
tasting spoon, small
cuiller de table, petit
cuchara menu, pequeño
cucchiaio menu, piccolo



■ 01.0115.6062
■ 11.0115.6042

Menuegabel, klein

196 mm/7³/₄ in.
tasting fork, small
fourchette de table, petite
tenedor menu, pequeño
forchetta menu, piccolo



■ 01.0103.6067
■ 11.0103.6047

Menuemesser*

231 mm/9 in.
table knife*
couteau de table*
cuchillo mesa*
coltello tavola cutinato*



■ 01.0103.6069
■ 11.0103.6049

Menuemesser**

231 mm/9 in.
table knife**
couteau de table**
cuchillo mesa**
coltello tavola cutinato**



■ 11.0133.6049

Menuemesser, lang**

240 mm/9¹/₂ in.
table knife**, long
couteau de table**, long
cuchillo mesa**
coltello tavola**, lungo



■ 01.0104.6060
■ 11.0104.6040

Vorspeisenlöffel

183 mm/7¹/₄ in.
dessert spoon
cuiller à dessert
cuchara postre
cucchiaio frutta



■ 01.0105.6060
■ 11.0105.6040

Vorspeisengabel

179 mm/7 in.
dessert fork
fourchette à dessert
tenedor postre
forchetta frutta



■ 01.0106.6067
■ 11.0106.6047

Vorspeisenmesser*

214 mm/8¹/₂ in.
dessert knife*
couteau à dessert*
cuchillo postre*
coltello frutta*



■ 01.0106.6069
■ 11.0106.6049

Vorspeisenmesser**

214 mm/8¹/₂ in.
dessert knife**
couteau à dessert**
cuchillo postre**
coltello frutta**



■ 01.0107.6060
■ 11.0107.6040

Kaffeelöffel

147 mm/5³/₄ in.
tea/coffee spoon
cuiller à café
cuchara café
cucchiaio caffè/tè



■ 01.0109.6060
■ 11.0109.6040

Espresso- / Mokkalöffel

114 mm/4¹/₂ in.
demi-tasse spoon
cuiller à mocca
cuchara mocha
cucchiaio mocha



■ 01.0110.6060
■ 11.0110.6040

Vorspeisen- / Dessertlöffel

165 mm/6¹/₂ in.
coffee/tea spoon, large
cuiller à café/tè, grande
cuchara à café/tè, grande
cucchiaio caffè/tè, grande



■ 01.0111.6060
■ 11.0111.6040

Gourmetlöffel

186 mm/7¹/₄ in.
gourmet spoon
cuiller à sauce
cuchara gourmet
cucchiaio gourmet



■ 01.0135.6062
■ 11.0135.6042

Fischgabel

179 mm/7 in.
fish fork
fourchette à poisson
tenedor pescado
forchetta pesce



■ 01.0135.6063
■ 11.0135.6043

Fischmesser

215 mm/8¹/₂ in.
fish knife
couteau à poisson
cuchillo pescado
coltello pesce



■ 01.0140.6060
■ 11.0140.6040

Austerngabel

141 mm/5¹/₂ in.
oyster fork
fourchette à huîtres
tenedor ostras
forchetta per ostriche



■ 01.0164.6060
■ 11.0164.6040

Kuchengabel

163 mm/6¹/₂ in.
cake fork
fourchette à gâteau
tenedor lunch
forchetta per dolce



■ 01.0166.6069
■ 11.0166.6049

Brot- / Buttermesser**

170 mm/6³/₄ in.
bread/butter knife**
couteau de table**
cuchillo lunch**
coltello per dolce**



■ 01.0172.6060
■ 11.0172.6040

Limolöffel

220 mm/8³/₄ in.
iced tea spoon
cuiller à soda
cuchara refresco
cucchiaio bibita



■ 01.0178.6067
■ 11.0178.6047

Steakmesser*

220 mm/8³/₄ in.
steak knife*
couteau à steak*
cuchillo steak*
coltello da bistecca



■ 11.0178.6049

Steakmesser**

220 mm/8³/₄ in.
steak knife**
couteau à steak**
cuchillo steak**
coltello da bistecca**



■ 01.0189.6060
■ 11.0189.6040

Tassenlöffel

168 mm/6³/₄ in.
round bowl soup spoon
cuiller à bouillon
cuchara sopa
cucchiaio da brodo



■ perfekte Versilberung / perfectly silverplated

■ Cromargan®, poliert / stainless 18/10, polished

* Hohlheft mit Wellenschliff / hollow-handled with serrated edge

** Klingenstahl mit Wellenschliff / monobloc with serrated edge



BAGUETTE 0100

■ 01 0100 6060

perfekt versilbert
perfectly silverplated
chromage parfait
plateado perfecto
perfetta placcatura in argento

■ 11 0100 6040

Cromargan®, poliert
Cromargan®, polished
Cromargan®, poli
Cromargan®, pulido
Cromargan®, lucido

- 10.0201.6060 **Menuelöffel**
 12.0201.6040
 200 mm/8 in.
 table spoon
 cuillère de table
 cuchara mesa
 cucchiaio tavola



- 10.0202.6060 **Menuegabel**
 12.0202.6040
 203 mm/8 in.
 table fork
 fourchette de table
 tenedor mesa
 forchetta tavola



- 12.0202.6042 **Menuegabel, lang**
 210 mm/8 1/4 in.
 table fork, long
 fourchette de table, longue
 tenedor mesa, de largo
 forchetta tavola, lungo



- 10.0203.6067 **Menuemesser***
 12.0203.6047
 225 mm/8 3/4 in.
 table knife*
 couteau de table*
 cuchillo mesa*
 coltello tavola cutinato*



- 10.0203.6069 **Menuemesser****
 12.0203.6049
 225 mm/8 3/4 in.
 table knife**
 couteau de table**
 cuchillo mesa**
 coltello tavola**



- 12.0233.6049 **Menuemesser**, lang**
 240 mm/9 1/2 in.
 table knife**, long
 couteau de table**, long
 cuchillo mesa**, de largo
 coltello tavola**, lungo



- 10.0204.6060 **Vorspeisenlöffel**
 12.0204.6040
 182 mm/7 1/4 in.
 dessert spoon
 cuiller à dessert
 cuchara postre
 cucchiaio frutta



- 10.0205.6060 **Vorspeisengabel**
 12.0205.6040
 185 mm/7 1/4 in.
 dessert fork
 fourchette à dessert
 tenedor postre
 forchetta frutta



- 10.0206.6067 **Vorspeisenmesser***
 12.0206.6047
 211 mm/8 3/4 in.
 dessert knife*
 couteau à dessert*
 cuchillo postre*
 coltello frutta*



- 10.0206.6069 **Vorspeisenmesser****
 12.0206.6049
 211 mm/8 3/4 in.
 dessert knife**
 couteau à dessert**
 cuchillo postre**
 coltello frutta**



- 10.0207.6060 **Kaffeelöffel**
 12.0207.6040
 132 mm/5 1/4 in.
 tea/coffee spoon
 cuiller à café
 cuchara café
 cucchiaio caffè/té



- 10.0209.6060 **Espresso- / Mokkalöffel**
 12.0209.6040
 108 mm/4 1/4 in.
 demi-tasse spoon
 cuiller à moca
 cuchara moca
 cucchiaio moca



- 10.0210.6060 **Vorspeisen- / Dessertlöffel**
 12.0210.6040
 148 mm/5 3/4 in.
 coffee/tea spoon, large
 cuiller à café/thé, grande
 cuchara à café/té, grande
 cucchiaio caffè/té, grande



- 10.0211.6060 **Gourmetlöffel**
 12.0211.6040
 190 mm/7 1/2 in.
 gourmet spoon
 cuiller à sauce
 cuchara gourmet
 cucchiaio gourmet



- 10.0235.6062 **Fischgabel**
 12.0235.6042
 174 mm/6 3/4 in.
 fish fork
 fourchette à poisson
 tenedor pescado
 forchetta pesce



- 10.0235.6063 **Fischmesser**
 12.0235.6043
 204 mm/8 in.
 fish knife
 couteau à poisson
 cuchillo pescado
 coltello pesce



- 10.0240.6060 **Austerngabel**
 12.0240.6040
 136 mm/5 1/4 in.
 oyster fork
 fourchette à huîtres
 tenedor ostras
 forchetta per ostriche



- 10.0264.6060 **Kuchengabel**
 12.0264.6040
 152 mm/6 in.
 cake fork
 fourchette à gâteau
 tenedor lunch
 forchetta per dolce

- 10.0266.6069 **Brot- / Buttermesser****
 12.0266.6049
 170 mm/6 3/4 in.
 bread/butter knife**
 couteau de table**
 cuchillo lunch**
 coltello per dolce**

- 10.0272.6060 **Limolöffel**
 12.0272.6040
 220 mm/8 3/4 in.
 iced tea spoon
 cuiller à soda
 cuchara refresco
 cucchiaio bibita

- 12.0278.6049 **Steakmesser****
 225 mm/8 3/4 in.
 steak knife**
 couteau à steak**
 cuchillo steak**
 coltello da bistecca**

- 10.0289.6060 **Tassenlöffel**
 12.0289.6040
 169 mm/6 3/4 in.
 round bowl soup spoon
 cuiller à bouillon
 cuchara sopa
 cucchiaio da brodo



■ perfekte Versilberung / perfectly silverplated
 ■ Cromargan®, poliert / stainless 18/10, polished
 * Hohlheft mit Wellenschliff / hollow-handled with serrated edge
 ** Klingenstahl mit Wellenschliff / monobloc with serrated edge



CONTOUR 0200

■ 10 0200 6060

perfekt versilbert
perfectly silverplated
chromage parfait
plateado perfecto
perfetta placcatura in argento

■ 12 0200 6040

Cromargan®, poliert
Cromargan®, polished
Cromargan®, poli
Cromargan®, pulido
Cromargan®, lucido

■ 10.4801.6060

Menuelöffel

■ 12.4801.6040

204 mm/8 in.
table spoon
cuiller de table
cuchara mesa
cucchiaio tavola

■ 10.4802.6060

Menuegabel

■ 12.4802.6040

202 mm/8 in.
table fork
fourchette de table
tenedor mesa
forchetta tavola

■ 12.4802.6042

**Menuegabel,
lang**210 mm/8 1/2 in.
table fork, long
fourchette de table, longue
tenedor mesa, largo
forchetta tavola, lungo

■ 10.4803.6067

Menuemesser*

■ 12.4803.6047

226 mm/9 in.
table knife*
couteau de table*
cuchillo mesa*
coltello tavola cutinato*

■ 10.4803.6069

Menuemesser**

■ 12.4803.6049

227 mm/9 in.
table knife**
couteau de table**
cuchillo mesa**
coltello tavola cutinato**

■ 12.4833.6049

Menuemesser,
lang**240 mm/9 1/2 in.
table knife**, long
couteau de table**, long
cuchillo mesa**, largo
coltello tavola**, lungo

■ 10.4804.6060

Vorspeisenlöffel

■ 12.4804.6040

187 mm/7 1/2 in.
dessert spoon
cuiller à dessert
cuchara postre
cucchiaio frutta

■ 10.4805.6060

Vorspeisengabel

■ 12.4805.6040

186 mm/7 1/4 in.
dessert fork
fourchette à dessert
tenedor postre
forchetta frutta

■ 10.4806.6067

**Vorspeisen-
messer***

■ 12.4806.6047

212 mm/8 1/2 in.
dessert knife*
couteau à dessert*
cuchillo lunch*
coltello frutta*

■ 10.4806.6069

**Vorspeisen-
messer****

■ 12.4806.6049

212 mm/8 1/2 in.
dessert knife**
couteau à dessert**
cuchillo postre**
coltello frutta**

■ 10.4807.6060

Kaffeelöffel

■ 12.4807.6040

132 mm/5 1/4 in.
tea/coffee spoon
cuiller à café
cuchara café
cucchiaio caffè/té

■ 10.4809.6060

**Espresso- /
Mokkalöffel**

■ 12.4809.6040

108 mm/4 1/4 in.
demi-tasse spoon
cuiller à moca
cuchara moca
cucchiaio moca

■ 10.4810.6060

**Vorspeisen- /
Dessertlöffel**

■ 12.4810.6040

157 mm/6 1/4 in.
coffee/tea spoon, large
cuiller à café/té, grande
cuchara à café/té, grande
cucchiaio caffè/té, grande

■ 10.4811.6060

Gourmetlöffel

■ 12.4811.6040

186 mm/7 3/4 in.
gourmet spoon
cuiller à sauce
cuchara gourmet
cucchiaio gourmet

■ 10.4835.6062

Fischgabel

■ 12.4835.6042

176 mm/7 in.
fish fork
fourchette à poisson
tenedor pescado
forchetta pesce

■ 10.4835.6063

Fischmesser

■ 12.4835.6043

198 mm/7 3/4 in.
fish knife
couteau à poisson
cuchillo pescado
coltello pesce

■ 10.4840.6060

Austerngabel

■ 12.4840.6040

140 mm/5 1/2 in.
oyster fork
fourchette à huîtres
tenedor ostras
forchetta per ostriche

■ 10.4864.6060

Kuchengabel

■ 12.4864.6040

157 mm/6 1/4 in.
cake fork
fourchette à gâteau
tenedor lunch
forchetta per dolce

■ 10.4866.6069

**Brot- /
Buttermesser****

■ 12.4866.6049

170 mm/6 3/4 in.
bread/butter knife**
couteau de table**
cuchillo lunch**
coltello per dolce**

■ 10.4872.6060

Limolöffel

■ 12.4872.6040

220 mm/8 3/4 in.
iced tea spoon
cuiller à soda
cuchara refresco
cucchiaio bibita

■ 12.4878.6047

Steakmesser*220 mm/8 3/4 in.
steak knife*
couteau à steak*
cuchillo steak*
coltello da bistecca*

■ 12.4878.6049

Steakmesser**228 mm/9 in.
steak knife**
couteau à steak**
cuchillo steak**
coltello da bistecca**

■ 10.4889.6060

Tassenlöffel

■ 12.4889.6040

166 mm/6 1/2 in.
round bowl soup spoon
cuiller à bouillon
cuchara sopa
cucchiaio da brodo■ perfekte Versilberung /
perfectly silverplated■ Cromargan®, poliert /
stainless 18/10, polished* Hohlheft mit Wellenschliff /
hollow-handled with serrated edge** Klingenstahl mit Wellenschliff /
monobloc with serrated edge



RESIDENCE 4800

■ 10 4800 6060

perfekt versilbert
perfectly silverplated
chromage parfait
plateado perfecto
perfetta placcatura in argento

■ 12 4800 6040

Cromargan®, poliert
Cromargan®, polished
Cromargan®, poli
Cromargan®, pulido
Cromargan®, lucido

■ 10.5401.6060
■ 12.5401.6040

Menuelöffel

199 mm/8 in.
table spoon
cuiller de table
cuchara mesa
cucchiaio tavola



■ 10.5402.6060
■ 12.5402.6040

Menuegabel

197 mm/7 1/2 in.
table fork
fourchette de table
tenedor mesa
forchetta tavola



■ 12.5402.6042

Menuegabel, lang

210 mm/8 1/2 in.
table fork, long
fourchette de table, longue
tenedor mesa, largo
forchetta tavola, lungo



■ 10.5403.6067
■ 12.5403.6047

Menuemesser*

216 mm/8 1/2 in.
table knife*
couteau de table*
cuchillo mesa*
coltello tavola cutinato*



■ 10.5403.6069
■ 12.5403.6049

Menuemesser**

215 mm/8 1/2 in.
table knife**
couteau de table**
cuchillo mesa**
coltello tavola cutinato**



■ 12.5433.6049

Menuemesser, lang**

240 mm/9 1/2 in.
table knife**, long
couteau de table**, long
cuchillo mesa**, largo
coltello tavola**, lungo



■ 10.5404.6060
■ 12.5404.6040

Vorspeisenlöffel

187 mm/7 1/2 in.
dessert spoon
cuiller à dessert
cuchara postre
cucchiaio frutta



■ 10.5405.6060
■ 12.5405.6040

Vorspeisengabel

185 mm/7 1/4 in.
dessert fork
fourchette à dessert
tenedor postre
forchetta frutta



■ 10.5406.6067
■ 12.5406.6047

Vorspeisenmesser*

205 mm/8 in.
dessert knife*
couteau à dessert*
cuchillo postre*
coltello frutta*



■ 10.5406.6069
■ 12.5406.6049

Vorspeisenmesser**

205 mm/8 in.
dessert knife**
couteau à dessert**
cuchillo postre**
coltello frutta**



■ 10.5407.6060
■ 12.5407.6040

Kaffeelöffel

132 mm/5 1/4 in.
tea/coffee spoon
cuiller à café
cuchara café
cucchiaio caffè/té



■ 10.5409.6060
■ 12.5409.6040

Espresso- / Mokkalöffel

108 mm/4 1/4 in.
demi-tasse spoon
cuiller à moca
cuchara moca
cucchiaio moca



■ 10.5410.6060
■ 12.5410.6040

Vorspeisen- / Dessertlöffel

156 mm/6 1/4 in.
coffee/tea spoon, large
cuiller à café/té, grande
cuchara à café/té, grande
cucchiaio caffè/té, grande



■ 10.5411.6060
■ 12.5411.6040

Gourmetlöffel

191 mm/7 1/2 in.
gourmet spoon
cuiller à sauce
cuchara gourmet
cucchiaio gourmet



■ 10.5435.6062
■ 12.5435.6042

Fischgabel

177 mm/7 in.
fish fork
fourchette à poisson
tenedor pescado
forchetta pesce



■ 10.5435.6063
■ 12.5435.6043

Fischmesser

199 mm/8 in.
fish knife
couteau à poisson
cuchillo pescado
coltello pesce



■ 10.5440.6060
■ 12.5440.6040

Austerngabel

141 mm/5 1/2 in.
oyster fork
fourchette à huîtres
tenedor ostras
forchetta per ostriche



■ 10.5464.6060
■ 12.5464.6040

Kuchengabel

157 mm/6 1/4 in.
cake fork
fourchette à gâteau
tenedor lunch
forchetta per dolce



■ 10.5466.6069
■ 12.5466.6049

Brot- / Buttermesser**

170 mm/6 3/4 in.
bread/butter knife**
couteau de table**
cuchillo lunch**
coltello per dolce**



■ 10.5472.6060
■ 12.5472.6040

Limolöffel

220 mm/8 3/4 in.
iced tea spoon
cuiller à soda
cuchara refresco
cucchiaio bibita



■ 12.5478.6047

Steakmesser*

222 mm/8 3/4 in.
steak knife*
couteau à steak*
cuchillo steak*
coltello da bistecca*



■ 12.5478.6049

Steakmesser**

229 mm/9 in.
steak knife**
couteau à steak**
cuchillo steak**
coltello da bistecca**



■ 10.5489.6060
■ 12.5489.6040

Tassenlöffel

166 mm/6 1/2 in.
round bowl soup spoon
cuiller à bouillon
cuchara sopa
cucchiaio da brodo



■ perfekte Versilberung / perfectly silverplated

■ Cromargan®, poliert / stainless 18/10, polished

* Hohlheft mit Wellenschliff / hollow-handled with serrated edge

** Klingenstahl mit Wellenschliff / monobloc with serrated edge



METROPOLITAN 5400

■ 10 5400 6060

perfekt versilbert
perfectly silverplated
chromage parfait
plateado perfecto
perfetta placcatura in argento

■ 12 5400 6040

Cromargan®, poliert
Cromargan®, polished
Cromargan®, poli
Cromargan®, pulido
Cromargan®, lucido

■ 10.1101.6060
 ■ 12.1101.6040
Menuelöffel
 207 mm/8¹/₄ in.
 table spoon
 cuiller de table
 cuchara mesa
 cucchiaio tavola



■ 10.1102.6060
 ■ 12.1102.6040
Menuegabel
 205 mm/8 in.
 table fork
 fourchette de table
 tenedor mesa
 forchetta tavola



■ 10.1103.6067
 ■ 12.1103.6047
Menuemesser*
 237 mm/9¹/₄ in.
 table knife*
 couteau de table*
 cuchillo mesa*
 coltello tavola cutinato*



■ 10.1103.6069
 ■ 12.1103.6049
Menuemesser**
 230 mm/9 in.
 table knife**
 couteau de table**
 cuchillo mesa**
 coltello tavola cutinato**



■ 10.1104.6060
 ■ 12.1104.6040
Vorspeisenlöffel
 183 mm/7¹/₄ in.
 dessert spoon
 cuiller à dessert
 cuchara postre
 cucchiaio frutta



■ 10.1105.6060
 ■ 12.1105.6040
Vorspeisengabel
 181 mm/7 in.
 dessert fork
 fourchette à dessert
 tenedor postre
 forchetta frutta



■ 10.1106.6067
 ■ 12.1106.6047
**Vorspeisen-
 messer***
 214 mm/8¹/₂ in.
 dessert knife*
 couteau à dessert*
 cuchillo postre*
 coltello frutta*



■ 10.1106.6069
 ■ 12.1106.6049
**Vorspeisen-
 messer****
 207 mm/8¹/₄ in.
 dessert knife**
 couteau à dessert**
 cuchillo postre**
 coltello frutta**



■ 10.1107.6060
 ■ 12.1107.6040
Kaffeelöffel
 132 mm/5¹/₄ in.
 tea/coffee spoon
 cuiller à café
 cuchara café
 cucchiaio caffè/té



■ 10.1109.6060
 ■ 12.1109.6040
**Espresso- /
 Mokkalöffel**
 108 mm/4¹/₄ in.
 demi-tasse spoon
 cuiller à mocca
 cuchara moca
 cucchiaio moca



■ 10.1110.6060
 ■ 12.1110.6040
**Vorspeisen- /
 Dessertlöffel**
 156 mm/6 in.
 coffee/tea spoon, large
 cuiller à café/té, grande
 cuchara à café/té, grande
 cucchiaio caffè/té, grande



■ 10.1111.6060
 ■ 12.1111.6040
Gourmetlöffel
 190 mm/7¹/₂ in.
 gourmet spoon
 cuiller à sauce
 cuchara gourmet
 cucchiaio gourmet



■ 10.1135.6062
 ■ 12.1135.6042
Fischgabel
 183 mm/7¹/₄ in.
 fish fork
 fourchette à poisson
 tenedor pescado
 forchetta pesce



■ 10.1135.6063
 ■ 12.1135.6043
Fischmesser
 206 mm/8 in.
 fish knife
 couteau à poisson
 cuchillo pescado
 coltello pesce



■ 10.1140.6060
 ■ 12.1140.6040
Austerngabel
 149 mm/5⁷/₈ in.
 oyster fork
 fourchette à huîtres
 tenedor ostras
 forchetta per ostriche



■ 10.1164.6060
 ■ 12.1164.6040
Kuchengabel
 157 mm/6¹/₄ in.
 cake fork
 fourchette à gâteau
 tenedor lunch
 forchetta per dolce



■ 10.1166.6069
 ■ 12.1166.6049
**Brot- /
 Buttermesser****
 170 mm/6⁷/₈ in.
 bread/butter knife**
 couteau de table**
 cuchillo lunch**
 coltello per dolce**



■ 10.1172.6060
 ■ 12.1172.6040
Limolöffel
 220 mm/8³/₄ in.
 iced tea spoon
 cuiller à soda
 cuchara refresco
 cucchiaio bibita



■ 10.1178.6069
 ■ 12.1178.6049
Steakmesser**
 226 mm/9 in.
 steak knife**
 couteau à steak**
 cuchillo steak**
 coltello da bistecca**



■ 10.1189.6060
 ■ 12.1189.6040
Tassenlöffel
 166 mm/6¹/₂ in.
 round bowl soup spoon
 cuiller à bouillon
 cuchara sopa
 cucchiaio da brodo



■ perfekte Versilberung /
 perfectly silverplated

■ Cromargan®, poliert /
 stainless 18/10, polished

* Hohlheft mit Wellenschliff /
 hollow-handled with serrated edge

** Klingenstahl mit Wellenschliff /
 monobloc with serrated edge



FLAIR 1100

■ 10 1100 6060

perfekt versilbert
perfectly silverplated
chromage parfait
plateado perfecto
perfetta placcatura in argento

■ 12 1100 6040

Cromargan®, poliert
Cromargan®, polished
Cromargan®, poli
Cromargan®, pulido
Cromargan®, lucido

■ 11.4701.6040

Menuelöffel

199 mm/8 in.
table spoon
cuiller de table
cuchara mesa
cucchiaio tavola



■ 11.4702.6040

Menuegabel

197 mm/7 7/8 in.
table fork
fourchette de table
tenedor mesa
forchetta tavola



■ 11.4703.6047

Menuemesser*

217 mm/8 1/2 in.
table knife*
couteau de table*
cuchillo mesa*
coltello tavola cutinato*



■ 11.4703.6049

Menuemesser**

215 mm/8 1/2 in.
table knife**
couteau de table**
cuchillo mesa**
coltello tavola cutinato**



■ 11.4733.6049

Menuemesser, lang**

240 mm/9 1/2 in.
table knife**, long
couteau de table**, long
cuchillo mesa**, largo
coltello tavola**, lungo



■ 11.4704.6040

Vorspeisenlöffel

183 mm/7 1/4 in.
dessert spoon
cuiller à dessert
cuchara postre
cucchiaio frutta



■ 11.4705.6040

Vorspeisengabel

181 mm/7 1/4 in.
dessert fork
fourchette à dessert
tenedor postre
forchetta frutta



■ 11.4706.6047

**Vorspeisen-
messer***

201 mm/8 in.
dessert knife*
couteau à dessert*
cuchillo postre*
coltello frutta*



■ 11.4706.6049

**Vorspeisen-
messer****

197 mm/7 7/8 in.
dessert knife**
couteau à dessert**
cuchillo postre**
coltello frutta**



■ 11.4707.6040

Kaffeelöffel

132 mm/5 1/4 in.
tea/coffee spoon
cuiller à café
cuchara café
cucchiaio caffè/té



■ 11.4709.6040

**Espresso- /
Mokkalöffel**

108 mm/4 1/4 in.
demi-tasse spoon
cuiller à moca
cuchara moca
cucchiaio moca



■ 11.4710.6040

**Vorspeisen- /
Dessertlöffel**

156 mm/6 1/4 in.
coffee/tea spoon, large
cuiller à café/té, grande
cuchara lunch
cucchiaio caffè/té, grande



■ 11.4711.6040

Gourmetlöffel

186 mm/7 3/8 in.
gourmet spoon
cuiller à sauce
cuchara gourmet
cucchiaio gourmet



■ 11.4735.6042

Fischgabel

183 mm/7 1/4 in.
fish fork
fourchette à poisson
tenedor pescado
forchetta pesce



■ 11.4735.6043

Fischmesser

206 mm/8 in.
fish knife
couteau à poisson
cuchillo pescado
coltello pesce



■ 11.4740.6040

Austerngabel

146 mm/5 3/4 in.
oyster fork
fourchette à huîtres
tenedor ostras
forchetta per ostriche



■ 11.4764.6040

Kuchengabel

157 mm/6 1/4 in.
cake fork
fourchette à gâteau
tenedor lunch
forchetta per dolce



■ 11.4766.6049

**Brot- /
Buttermesser****

170 mm/6 3/4 in.
bread/butter knife**
couteau de table**
cuchillo lunch**
coltello per dolce**



■ 11.4772.6040

Limolöffel

220 mm/8 3/4 in.
iced tea spoon
cuiller à soda
cuchara refresco
cucchiaio bibita



■ 11.4778.6049

Steakmesser**

219 mm/8 3/4 in.
steak knife**
couteau à steak**
cuchillo steak**
coltello da bistecca**



■ 11.4789.6040

Tassenlöffel

166 mm/6 1/2 in.
round bowl soup spoon
cuiller à bouillon
cuchara sopa
cucchiaio da brodo



- Cromargan®, poliert / stainless 18/10, polished
- * Hohlheft mit Wellenschliff / hollow-handled with serrated edge
- ** Klingenstahl mit Wellenschliff / monobloc with serrated edge



CLUB 4700

■ 11 4700 6040

Cromargan®, poliert
Cromargan®, polished
Cromargan®, poli
Cromargan®, pulido
Cromargan®, lucido

■ 54.1801.6040

Menuelöffel

212 mm/8¹/₄ in.
table spoon
cuiller de table
cuchara mesa
cucchiaio tavola



■ 54.1864.6040

Kuchengabel

159 mm/6¹/₄ in.
cake fork
fourchette à gâteau
tenedor lunch
forchetta per dolce



■ 54.1802.6040

Menuegabel

211 mm/8¹/₄ in.
table fork
fourchette de table
tenedor mesa
forchetta tavola



■ 54.1866.6049

**Brot- /
Buttermesser****

180 mm/7 in.
bread/butter knife**
couteau de table**
cuchillo lunch**
coltello per dolce**



■ 54.1803.6049

Menuemesser**

234 mm/9¹/₄ in.
table knife**
couteau de table**
cuchillo mesa**
coltello tavola cutinato**



■ 54.1889.6040

Tassenlöffel

170 mm/6³/₄ in.
round bowl soup spoon
cuiller à bouillon
cuchara sopa
cucchiaio da brodo



■ 54.1804.6040

Vorspeisenlöffel

190 mm/7¹/₂ in.
dessert spoon
cuiller à dessert
cuchara postre
cucchiaio frutta



■ 54.1805.6040

Vorspeisengabel

189 mm/7¹/₂ in.
dessert fork
fourchette à dessert
tenedor postre
forchetta frutta



■ 54.1806.6049

**Vorspeisen-
messer****

210 mm/8¹/₄ in.
dessert knife**
couteau à dessert**
cuchillo postre**
coltello frutta**



■ 54.1807.6040

Kaffeelöffel

136 mm/5¹/₄ in.
tea/coffee spoon
cuiller à café
cuchara café
cucchiaio caffè/té



■ 54.1809.6040

**Espresso- /
Mokkalöffel**

108 mm/4¹/₄ in.
demi-tasse spoon
cuiller à mocca
cuchara moca
cucchiaio moca



■ 54.1810.6040

**Vorspeisen- /
Dessertlöffel**

158 mm/6¹/₄ in.
coffee/tea spoon, large
cuiller à café/thé, grande
cuchara à café/té, grande
cucchiaio caffè/té, grande



■ 54.1836.6040

Fischmesser

208 mm/8¹/₄ in.
fish knife
couteau à poisson
cuchillo pescado
coltello pesce



■ Cromargan®, poliert /
stainless 18/10, polished

** Klingenstahl mit Wellenschliff /
monobloc with serrated edge



TELOS 1800

■ 54 1800 6040

Cromargan®, poliert
Cromargan®, polished
Cromargan®, poli
Cromargan®, pulido
Cromargan®, lucido

■ 12.2301.6040

Menuelöffel

199 mm/7⁷/₈ in.
table spoon
cuiller de table
cuchara mesa
cucchiaio tavola



■ 12.2364.6040

Kuchengabel

157 mm/6¹/₄ in.
cake fork
fourchette à gâteau
tenedor lunch
forchetta per dolce



■ 12.2302.6040

Menuegabel

197 mm/7⁷/₈ in.
table fork
fourchette de table
tenedor mesa
forchetta tavola



■ 12.2366.6049

**Brot- /
Buttermesser****

177 mm/7 in.
bread/butter knife**
couteau de table**
cuchillo lunch**
coltello per dolce**



■ 12.2303.6049

Menuemesser**

226 mm/9 in.
table knife**
couteau de table**
cuchillo mesa**
coltello tavola cutinato**



■ 12.2389.6040

Tassenlöffel

166 mm/6¹/₂ in.
round bowl soup spoon
cuiller à bouillon
cuchara sopa
cucchiaio da brodo



■ 12.2304.6040

Vorspeisenlöffel

187 mm/7¹/₄ in.
dessert spoon
cuiller à dessert
cuchara postre
cucchiaio frutta



■ 12.2305.6040

Vorspeisengabel

185 mm/7³/₈ in.
dessert fork
fourchette à dessert
tenedor postre
forchetta frutta



■ 12.2306.6049

**Vorspeisen-
messer****

213 mm/8¹/₂ in.
dessert knife**
couteau à dessert**
cuchillo postre**
coltello frutta**



■ 12.2307.6040

Kaffeelöffel

132 mm/5¹/₄ in.
tea/coffee spoon
cuiller à café
cuchara café
cucchiaio caffè/té



■ 12.2309.6040

**Espresso- /
Mokkalöffel**

108 mm/4¹/₄ in.
demi-tasse spoon
cuiller à mocca
cuchara moca
cucchiaio moca



■ 12.2310.6040

**Vorspeisen- /
Dessertlöffel**

156 mm/6¹/₄ in.
coffee/tea spoon, large
cuiller à café/thé, grande
cuchara à café/té, grande
cucchiaio caffè/té, grande



■ 12.2335.6043

Fischmesser

199 mm/7⁷/₈ in.
fish knife
couteau à poisson
cuchillo pescado
coltello pesce



■ Cromargan® /
stainless 18/10

** Klingenstahl mit Wellenschliff /
monobloc with serrated edge



BASE 2300

■ 12 2300 6040

Cromargan®, poliert
Cromargan®, polished
Cromargan®, poli
Cromargan®, pulido
Cromargan®, lucido

■ 12.0801.6040

Menuelöffel

195 mm/7³/₄ in.
table spoon
cuiller de table
cuchara mesa
cucchiaio tavola



■ 12.0802.6040

Menuegabel

193 mm/7¹/₂ in.
table fork
fourchette de table
tenedor mesa
forchetta tavola



■ 12.0803.6047

Menuemesser*

209 mm/8¹/₄ in.
table knife*
couteau de table*
cuchillo mesa*
coltello tavola cutinato*



■ 12.0803.6049

Menuemesser**

209 mm/8¹/₄ in.
table knife**
couteau de table**
cuchillo mesa**
coltello tavola cutinato**



■ 12.0804.6040

Vorspeisenlöffel

182 mm/7¹/₄ in.
dessert spoon
cuiller à dessert
cuchara postre
cucchiaio frutta



■ 12.0805.6040

Vorspeisengabel

180 mm/7 in.
dessert fork
fourchette à dessert
tenedor postre
forchetta frutta



■ 12.0806.6047

**Vorspeisen-
messer***

195 mm/7³/₄ in.
dessert knife*
couteau à dessert*
cuchillo postre*
coltello frutta*



■ 12.0806.6049

**Vorspeisen-
messer****

195 mm/7³/₄ in.
dessert knife**
couteau à dessert**
cuchillo postre**
coltello frutta**



■ 12.0807.6040

Kaffeelöffel

132 mm/5¹/₄ in.
tea/coffee spoon
cuiller à café
cuchara café
cucchiaio caffè/té



■ 12.0809.6040

**Espresso- /
Mokkalöffel**

108 mm/4¹/₄ in.
demi-tasse spoon
cuiller à mocca
cuchara moca
cucchiaio moca



■ 12.0810.6040

**Vorspeisen- /
Dessertlöffel**

156 mm/6¹/₄ in.
coffee/tea spoon, large
cuiller à café/thé, grande
cuchara lunch
cucchiaio caffè/té grande



■ 12.0811.6040

Gourmetlöffel

190 mm/7¹/₂ in.
gourmet spoon
cuiller à sauce
cuchara gourmet
cucchiaio gourmet



■ 12.0835.6042

Fischgabel

178 mm/7 in.
fish fork
fourchette à poisson
tenedor pescado
forchetta pesce



■ 12.0835.6043

Fischmesser

205 mm/8 in.
fish knife
couteau à poisson
cuchillo pescado
coltello pesce



■ 12.0864.6040

Kuchengabel

157 mm/6¹/₄ in.
cake fork
fourchette à gâteau
tenedor lunch
forchetta per dolce



■ 12.0866.6049

**Brot- /
Buttermesser****

168 mm/6¹/₂ in.
bread/butter knife**
couteau de table**
cuchillo lunch**
coltello per dolce**



■ 12.0872.6040

Limolöffel

220 mm/8³/₄ in.
iced tea spoon
cuiller à soda
cuchara refresco
cucchiaio bibita



■ 12.0878.6047

Steakmesser*

232 mm/9¹/₄ in.
steak knife*
couteau à steak*
cuchillo steak*
coltello da bistecca*



■ 12.0878.6049

Steakmesser**

232 mm/9¹/₄ in.
steak knife**
couteau à steak**
cuchillo steak**
coltello da bistecca**



■ 12.0889.6040

Tassenlöffel

168 mm/6¹/₂ in.
round bowl soup spoon
cuiller à bouillon
cuchara sopa
cucchiaio da brodo



■ Cromargan®, poliert /
stainless 18/10, polished
* Hohlheft mit Wellenschliff /
hollow-handled with serrated edge
** Klingenstahl mit Wellenschliff /
monobloc with serrated edge



GASTRO 0800

■ 12 0800 6040

Cromargan®, poliert
 Cromargan®, polished
 Cromargan®, poli
 Cromargan®, pulido
 Cromargan®, lucido

■ 11.0001.6030

Menuelöffel

190 mm/7 1/2 in.



table spoon
cuiller de table
cuchara mesa
cucchiaio tavola

■ 11.0002.6030

Menuegabel

190 mm/7 1/2 in.



table fork
fourchette de table
tenedor mesa
forchetta tavola

■ 11.0003.6037

Menuemesser*

208 mm/8 1/4 in.



table knife*
couteau de table*
cuchillo mesa*
coltello tavola cutinato*

■ 11.0003.6039

Menuemesser**

208 mm/8 1/4 in.



table knife**
couteau de table**
cuchillo mesa**
coltello tavola cutinato**

■ 11.0007.6030

Kaffeelöffel

132 mm/5 1/4 in.



tea/coffee spoon
cuiller à café
cuchara café
cucchiaio caffè/té

■ 11.0010.6030

**Vorspeisen- /
Dessertlöffel**

156 mm/6 1/4 in.



coffee/tea spoon, large
cuiller à café/té, grande
cuchara à café/té, grande
cucchiaio caffè/té, grande

■ 11.0035.6033

Fischmesser

199 mm/8 in.



fish knife
couteau à poisson
cuchillo pescado
coltello pesce

■ 11.0064.6030

Kuchengabel

157 mm/6 1/4 in.



cake fork
fourchette à gâteau
tenedor lunch
forchetta per dolce

■ 11.0066.6039

**Brot- /
Buttermesser****

168 mm/6 3/4 in.



bread/butter knife**
couteau de table**
cuchillo lunch**
coltello per dolce**

- Chromstahl, matt /
chrome steel, satin finished
- * Hohlheft mit Wellenschliff /
hollow-handled with serrated edge
- ** Klingenstahl mit Wellenschliff /
monobloc with serrated edge



GASTROLIN 0000

■ 11 0000 6030

Chromstahl, matt
 Chrome steel, satin
 Acier chrome, mat
 Acciaio al cromo, mate
 Acciaio al cromo, satinato

Chafing Dish - Besteck

chafing dish serving set
service pour chafing dish
cubierto servir chafing dish
posate chafing dish

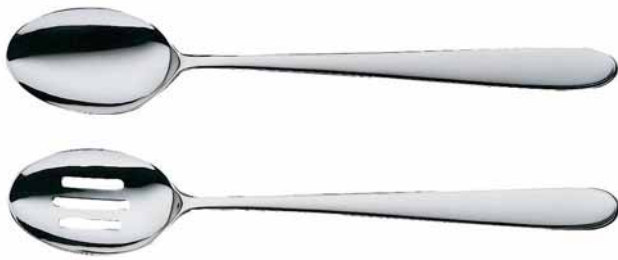

	Länge cm	length in.	Cromargan® stainless 18/10	versilbert silverplated
Chafing Dish Löffel / chafing dish spoon	39	15 1/4	12.8387.6041	10.8387.6061
Chafing Dish Gabel / chafing dish fork	39	15 1/4	12.8387.6042	10.8387.6062

Salat-/Vorlegebesteck

salad/buffet serving set
couvert à salade/servir
cubierto ensalada/servir
posate servire insalata



	Länge cm	length in.	Cromargan® stainless 18/10	versilbert silverplated
Chafing Dish Löffel / chafing dish spoon	26	10 1/4	12.8386.6041	10.8386.6061
Chafing Dish Gabel / chafing dish fork	26	10 1/4	12.8386.6042	
Chafing Dish Gabel / chafing dish fork	26	10 1/4	12.8249.6040	10.8249.6060
Salatgabel / salad fork	26	10 1/4	12.8343.6042	10.8343.6062

Chafing Dish - Besteck

chafing dish serving set
service pour chafing dish
cubierto servir chafing dish
posate chafing dish



Hohlheftgriff /
hollow-handled

Cromargan® / stainless 18/10

	Länge cm	length in.	
Chafing Dish Löffel / chafing dish spoon	32,5	12 3/4	12.8381.6041
Chafing Dish Gabel / chafing dish fork	32,5	12 3/4	12.8381.6042

Fleischgabel

serving fork
fourchette à viande
tenedor carne
forchetta da antipasto



Hohlheftgriff /
hollow-handled

Cromargan® / stainless 18/10

Länge cm	length in.	
32,5	12 3/4	12.8382.6040



Nudellöffel

pasta serving spoon
cuillère à spaghetti
cuchara pasta
cuchiao per pasta

Hohlheftgriff /
hollow-handled

Cromargan® / stainless 18/10

Länge	length
cm	in.
31,5	12 ¹ / ₂

12.8383.6040



Parmesanreibe mit Behälter

parmesan grater with storage box
râpe à parmesan avec boîte fraîcheur
rallador queso
grattuggia formaggio con contenitore

Cromargan® / stainless 18/10

Länge	length
cm	in.
14	5 ¹ / ₂

06.0559.6030



Salatzange

salad serving tongs
pince à salade
pinza para ensalada
pinza servire insalata

Länge	length
cm	in.
31	12 ¹ / ₄

Cromargan®	versilbert
stainless 18/10	silverplated
12.8341.6040	10.8341.6060



Salatzange

salad serving tongs
pince à salade
pinza para ensalada
pinza servire insalata

Cromargan® / stainless 18/10

Länge	length
cm	in.
30,5	12

12.8306.6040



**Universalzange
Prof. Wagenfeld**
pastry serving tongs
pince à gâteau
pinza pasteles
pinza universale

Länge	length
cm	in.
20,5	8

Cromargan® mattiert stainless 18/10, satin finished	versilbert silverplated
12.8246.6030	10.8246.6060



Universalzange
pastry serving tongs
pince à gâteau
pinza pasteles
pinza universale

Cromargan® / stainless 18/10

Länge	length
cm	in.
23	9

12.8945.6040



Eiszange

ice tongs
pince à glace
pinza hielo
pinza per ghiaccio

Länge	length
cm	in.
17,3	6¾

Cromargan® stainless 18/10	versilbert silverplated
12.8307.6040	10.8307.6060



Gebäck- und Servierzange

pastry serving tongs
pince à gâteau
pinza pasteles
pinza servire per dolci

Cromargan® teilmattiert / stainless 18/10 partly satin finished

Länge	length
cm	in.
17	6¾

12.8362.6040



Zuckerzange

sugar tongs
pince à sucre
pinza de azucar
pinza per zucchero

Länge	length
cm	in.
10,7	4 ¹ / ₄

Cromargan®	versilbert
stainless 18/10	silverplated
12.8342.6040	10.8342.6060



Hummergabel

lobster fork
fourchette à homard
tenedor bogavante
forchetta aragosta

Länge	length
cm	in.
23,5	9 ¹ / ₄

Cromargan®	versilbert
stainless 18/10	silverplated
12.8336.6040	10.8336.6060



Hummerzange

lobster-crack
pince à homard
pinza para langostas
pinza per aragoste

Chromstahl / chrome steel

Länge	length
cm	in.
19,8	7 ³ / ₄

12.8410.6040



Schneckengabel

snail fork
fourchette à escargots
tenedor caracoles
forchetta per lumache

Länge	length
cm	in.
14,5	5 ³ / ₄

Cromargan®	versilbert
stainless 18/10	silverplated
12.8335.6040	10.8335.6060



Schneckenzange

snail tweezer
pince à escargots
pinza caracoles
pinza per lumache

Cromargan® / stainless 18/10

Länge	length
cm	in.
15	6

12.8291.6040



Dressinglöffel

dressing ladle
cuiller à sauce
cazo salsa
mestolino salsa

Cromargan® / stainless 18/10

Länge	length	Inhalt	cap.	Ø	Ø
cm	in.	Ltr.	oz.	cm	in.
26	10 ¹ / ₄	0,03	1,05	6,5	2 ¹ / ₂

12.8207.6040



Bowlenlöffel

punch bowl ladle
cuiller à punch
cazo ponche
cucchiaio per bowl

Cromargan® / stainless 18/10

Länge	length	Inhalt	cap.
cm	in.	Ltr.	oz.
40	15 ³ / ₄	0,08	2,70

12.8344.6040



Saucenlöffel

gravy ladle
cuiller à sauce
cazo salsa
mestolino salsa

Cromargan® / stainless 18/10

Länge	length	Inhalt	cap.
cm	in.	Ltr.	oz.
18	7	0,03	1,05

12.8395.6040



Portionsschöpfer

soup ladle, medium
louche, medium
cazo porciones
ramaiolo, medio

Cromargan® / stainless 18/10

Länge	length	Inhalt	cap.
cm	in.	Ltr.	oz.
26,4	10½	0,06	2,03

12.8423.6040



Suppenschöpfer

soup ladle
louche à potage
cazo sopa
ramaiolo

Cromargan® / stainless 18/10

Länge	length	Inhalt	cap.
cm	in.	Ltr.	oz.
29,5	11½	0,11	3,72

54.9904.6040



Kartoffellöffel

potato spoon
cuiller à pommes de terre
cucharon patatas
cucchiaio per patate

Cromargan® / stainless 18/10

Länge	length
cm	in.
21,5	8½

12.8394.6040



Eisschaufel

ice-shovel
cuiller à glace
pala para hielo
cucchianino per gelato

Cromargan® / stainless 18/10

Länge	length
cm	in.
13,8	5½

12.8057.6040



Eierlöffel

egg spoon
cuiller à oeuf
cuchara huevos
cucchiaio per uovo

Cromargan® / stainless 18/10

Länge	length
cm	in.
13	5

12.9008.6040



Vorlege-/ Aufschnittgabel

serving fork
fourchette à viande
tenedor carne
forchetta da antipasto

Cromargan® / stainless 18/10

Länge	length
cm	in.
19	7½

12.8393.6040



Brotmesser

GRAND GOURMET

bread knife
couteau à pain
cuchillo pan
coltello pane

Spezialklingenstahl, Cromargan® /
special blade steel, stainless 18/10

Länge	length
cm	in.
32	12½

18.8950.6030



Brotmesser

SPITZENKLASSE PLUS

bread knife
couteau à pain
cuchillo pan
coltello pane

Spezialklingenstahl, Cromargan® /
special blade steel, stainless 18/10

Länge	length
cm	in.
31,5	12½

18.9576.6031



**Tranchiermesser
GRAND GOURMET**

carving knife
couteau à viande
cuchillo carne
coltello carne

Spezialklingenstahl, Cromargan® /
special blade steel, stainless 18/10

Gesamtlänge cm	total length in.	Klingenlänge cm	length of blade in.
32,5	12 ³ / ₄	20	8

18.8948.6030



**Tranchiergabel
GRAND GOURMET**

meat fork
fourchette à viande
tenedor carne
forchettone

Cromargan® / stainless 18/10

Gesamtlänge cm	total length in.	Klingenlänge cm	length of blade in.
29	11 ¹ / ₂	14	5 ¹ / ₂

18.8957.6030



**Tranchiermesser
SPITZENKLASSE PLUS**

carving knife
couteau à viande
cuchillo carne
coltello carne

Spezialklingenstahl, Cromargan® /
special blade steel, stainless 18/10

Gesamtlänge cm	total length in.	Klingenlänge cm	length of blade in.
32	12 ¹ / ₂	20	8

18.9582.6031



**Tranchiergabel
SPITZENKLASSE PLUS**

meat fork
fourchette à viande
tenedor carne
forchettone

Spezialklingenstahl, Cromargan® /
special blade steel, stainless 18/10

Gesamtlänge cm	total length in.	Klingenlänge cm	length of blade in.
27	10 ³ / ₄	12	4 ³ / ₄

18.9588.6031



Steakbesteck SOLID

steak fork and knife SOLID
 couvert à steak SOLID
 cubierto steak SOLID
 posate da bistecca SOLID

Cromargan® / stainless 18/10

	Länge cm	length in.	
Steakgabel SOLID / steak fork SOLID	21	8 ¹ / ₄	12.9013.6040
Steakmesser SOLID* / steak knife SOLID*	24,4	9 ³ / ₄	12.9014.6040*

* Hohlheft mit Wellenschliff / hollow-handled with serrated edge



Steakbesteck

steak flatware
 couvert à steak
 cubierto steak
 posate da bistecca

Cromargan® / stainless 18/10

	Länge cm	length in.	
Steakgabel / steak fork	21	8 ¹ / ₄	12.8960.6042
Steakmesser / steak knife	23,1	9	12.8960.6049



Steakmesser

steak knife
 couteau à steak
 cuchillo steak
 coltello da bistecca

Cromargan® / stainless 18/10

Länge cm	length in.	
20	8	12.8705.6047



Steakmesser*

steak knife*
 couteau à steak*
 cuchillo steak*
 coltello da bistecca*

Cromargan®, poliert / stainless 18/10, polished

Länge mm	length in.	
220	8 ³ / ₄	11.0178.6047

* Hohlheft mit Wellenschliff / hollow-handled with serrated edge



Fischservierbesteck

fish servers
 couvert à servir le poisson
 cubierto servir pescado
 posate servire pesce

Cromargan® / stainless 18/10

Länge	length
cm	in.
23	9

12.8859.6040



Kaviarlöffel

caviar spoon
 cuiller à caviar
 cuchara caviar
 cucchiaio per caviale

versilbert / silverplated

Länge	length
cm	in.
20	8

01.0195.6062



Kaviarmesser

caviar knife
 couteau à caviar
 cuchillo caviar
 coltellino per caviale

versilbert / silverplated

Länge	length
cm	in.
21	8 ¹ / ₄

01.0195.6063



Happy Spoon

happy spoon
 happy spoon
 happy spoon
 happy spoon

in Menue- und Vorspeisengröße! /
 in size table and dessert spoon!

Cromargan® / stainless 18/10

	Länge	length	
	cm	in.	
Happy Spoon	12,5	5	12.8993.6040
Happy Spoon S	11,5	4 ¹ / ₂	12.8345.6040



Tortenheber

pie server, large
pelle à gâteau, grande
pala tarta, grande
pala da torta, grande

Länge	length
cm	in.
26	10 ¹ / ₄

Cromargan®	versilbert
stainless 18/10	silverplated
12.8424.6040	10.8424.6060



Käsemesser

cheese knife
couteau à fromage
cuchillo queso
coltello formaggio

Cromargan® / stainless 18/10

Länge	length
cm	in.
22	8 ³ / ₄

12.8861.6040



„4 for you“ - Löffel

„4 for you“ spoon
cuiller „4 for you“
cuchara „4 for you“
cucchiaio „4 for you“

Chromstahl / chrome steel

	Länge	length	
	cm	in.	
Gewürzlöffel / spicy spoon	7	2 ³ / ₄	54.9184.6040
Espressolöffel / demi-tasse spoon	10,5	4 ¹ / ₄	12.9185.6040
Kaffeelöffel / coffee spoon	13,5	5 ¹ / ₄	12.9186.6040
Muglöffel / mug spoon	15,5	6	12.9187.6040
Eiskaffeelöffel / iced tea spoon	19,5	7 ¹ / ₂	12.9188.6040



Löffel „KaffeeKultur“

spoons „KaffeeKultur“
cuillers „KaffeeKultur“
cucharas „KaffeeKultur“
cucchiai „KaffeeKultur“

Cromargan® / stainless 18/10

Länge	length
mm	in.
110	4 ¹ / ₄
136	5 ¹ / ₄
157	6 ¹ / ₄

54.9901.6040
54.9902.6040
54.9903.6040

**Eislöffel XL**

ice spoon XL

cuiller à glace XL

pala para hielo XL

cucchianino per gelato XL

Cromargan® / stainless 18/10

Länge	length
mm	in.
180	7

54.9905.6040



Kinderset, 4 tlg., LILLEBI

4-pc. child's set, LILLEBI
couvert enfant, 4 parties, LILLEBI
cubierto niño, 4 pzas, LILLEBI
set per bambini, LILLEBI, 4 pz.

Cromargan® / stainless 18/10

12.9200.6040



Kinderset, 4 tlg., SAFARI

4-pc. child's set, SAFARI
couvert enfant, 4 parties, SAFARI
cubierto niño, 4 pzas, SAFARI
set per bambini, SAFARI, 4 pz.

Cromargan® / stainless 18/10

12.8002.6040

TABLE TOP

Getränke heiß & kalt

beverages hot & cold

Servieren

serving

Tischdekoration

table decoration

Würzen

spice it up





Latte Macchiato-Set

KaffeeKultur

latte macchiato set
kit latte-macchiato
juego latte macchiato
set latte-macchiato

bestehend aus: 6 Unterteller, 6 Gläser L bedruckt mit „Latte Macchiato“,
6 Ringe L, 6 Muglöffel /
consisting of: 6 serving trays, 6 glasses L printed with „Latte
Macchiato“, 6 rings L, 6 mug spoons

Cromargan®, Glas / stainless 18/10, glass

06.2516.6040



Milchkaffee-Set

KaffeeKultur

caffè Latte set
kit café au lait
juego café con leche
set café latte

bestehend aus: 6 Unterteller, 6 Gläser L unbedruckt, 6 Griffe L,
6 Muglöffel /
consisting of: 6 serving trays, 6 glasses L unprinted, 6 handles L,
6 mug spoons

Cromargan®, Glas / stainless 18/10, glass

06.2519.6040



Espresso-Set

KaffeeKultur

espresso set
kit espresso
juego espresso
set da café espresso

bestehend aus: 6 Unterteller, 6 Porzellantassen S, 6 Griffe S, 6 Gläser S,
6 Ringe S, 6 Löffel S /
consisting of: 6 serving trays, 6 porcelain cups S, 6 handles S,
6 glasses S, 6 rings S, 6 spoons S

Cromargan®, Glas, Porzellan /
stainless 18/10, glass, porcelain

06.2518.6040



Café Crème-Set

KaffeeKultur

café crème set
kit café crème
juego café-crème
set café crème

bestehend aus: 6 Unterteller, 6 Porzellantassen M, 6 Griffe M,
6 Gläser S, 6 Ringe S, 6 Löffel M /
consisting of: 6 serving trays, 6 porcelain cups M, 6 handles M,
6 glasses S, 6 rings S, 6 spoons M

Cromargan®, Glas, Porzellan /
stainless 18/10, glass, porcelain

06.2517.6040



Café au Lait-Set KaffeeKultur

café au lait set
kit café au lait
juego café con leche
set café au lait

bestehend aus: 6 Unterteller, 6 Milchkaffeeschalen, 6 Ringe XL,
6 Muglöffel /
consisting of: 6 serving trays, 6 milk coffee pots, 6 rings XL, 6 mug
spoons

Cromargan®, Porzellan / stainless 18/10, porcelain **06.2527.6040**



Doppel-Espresso-Set KaffeeKultur

espresso double set
kit espresso double
juego espresso doble
set café espresso doppio

bestehend aus: 6 Unterteller, 6 Doppel-Espresso-Tassen, 6 Griffe S,
6 Gläser S, 6 Ringe S, 6 Espressolöffel /
consisting of: 6 serving trays, 6 cups Espresso double, 6 handles S,
6 glasses S, 6 rings S, 6 demi-tasse spoons

Cromargan®, Glas, Porzellan /
stainless 18/10, glass, porcelain

55.0043.6040



Allround „KaffeeKultur-Set“ (über 100 Teile!)

all-round „KaffeeKultur Set“, (over 100 pieces!)
„kit KaffeeKultur“ polyvalent, (plus de 100 pièces!)
juego universal para el „KaffeeKultur“, (más de 100 piezas!)
set „KaffeeKultur“ completo

Das Allround-Set umfasst alles, was Sie für eine Belegung des Kaffeeumsatzes benötigen. Bestehend aus den unten aufgeführten Produkten.

The all-round set includes everything you need to boost your coffee sales. Consisting of the below listed items.

Cromargan®, Glas, Porzellan /
stainless 18/10, glass, porcelain

06.2520.6040

12 Unterteller	12 serving trays
6 Gläser L (bedruckt)	6 glasses L (printed)
6 Gläser L (unbedruckt)	6 glasses L (unprinted)
12 Gläser S	12 glasses S
6 Porzellantassen M	6 porcelain cups M
6 Porzellantassen S	6 porcelain cups S
6 Ringe L	6 rings L
12 Ringe S	12 rings S
6 Griffe L	6 handles L
6 Griffe M	6 handles M
6 Griffe S	6 handles S
6 Muglöffel	6 mug spoons
6 Kaffeelöffel	6 tea/coffee spoons
6 Espressolöffel	6 demi-tasse spoons



①



②



③



④



⑤



⑥



⑦



⑧



⑨



⑩



⑪



⑫



⑬



⑭



⑮



⑯



⑰



⑱

Einzelartikel „KaffeeKultur“

single items „KaffeeKultur“
articles isolés „KaffeeKultur“
artículos diversos „KaffeeKultur“
singolo articolo „KaffeeKultur“

Cromargan®, Glas, Porzellan / stainless 18/10, glass, porcelain

① Unterteller / serving tray

Größe	size	
cm	in.	
18,8 x 12 x 2	7 1/2 x 4 3/4 x 3/4	

06.2500.6040

② Glas L bedruckt / glass L printed

Höhe	height	Inhalt	cap.
cm	in.	Ltr.	oz.
11,6	4 1/2	0,32	11,2

60.2505.9990

③ Glas L unbedruckt / glass L unprinted

Höhe	height	Inhalt	cap.
cm	in.	Ltr.	oz.
11,6	4 1/2	0,32	11,2

60.2505.9991

④ Glas S / glass S

Höhe	height	Inhalt	cap.
cm	in.	Ltr.	oz.
7,4	3	0,09	3,2

60.2506.9990

⑤ Milchkaffeeschale / milk coffee pot

Höhe	height	Inhalt	cap.
cm	in.	Ltr.	oz.
9,6	3 3/4	0,35	12,25

60.2526.9990

⑥ Porzellantasse M / porcelain cup M

Höhe	height	Inhalt	cap.
cm	in.	Ltr.	oz.
9,6	3 3/4	0,25	8,45

60.2507.9990

⑦ Doppel-Espressotasse / Espresso cup double

Höhe	height	Inhalt	cap.	Ø	Ø
cm	in.	Ltr.	oz.	cm	in.
8,4	3 1/4	0,1	3,38	6,2	2 1/2

60.2541.9990

⑧ Porzellantasse S / porcelain cup S

Höhe	height	Inhalt	cap.
cm	in.	Ltr.	oz.
7,4	3	0,09	3,2

60.2508.9990

⑨ Ring XL / ring XL

passend auf Milchkaffeeschale /
fitting on milk coffee pot

06.2525.6040

⑩ Ring L / ring L

passend auf Glas L / fitting on glass L

06.2501.6040

⑪ Ring S / ring S

passend auf Glas S, Tasse S, Doppel-Espresso-Tasse
und Sahnekännchen von KaffeeKultur /
fitting on glass S, cup S, Espresso double cup and
creamer of CoffeeCulture

06.2502.6040

⑫ Griff L / handle L

passend auf Glas L / fitting on glass L

06.2503.6040

⑬ Griff M / handle M

passend auf Porzellantasse M /
fitting on porcelain cup M

06.2504.6040

⑭ Griff S / handle S

passend auf Glas S, Porzellantasse S, Doppel-
Espressotasse und Sahnekännchen von KaffeeKultur /
fitting on glass S, porcelain cup S, Espresso cup
double and creamer of CoffeeCulture

06.2509.6040

⑮ Muglöffel / mug spoon

Länge	length
mm	in.
157	6 1/4

54.9903.6040

⑯ Kaffeelöffel / tea/coffee spoon

Länge	length
mm	in.
136	5 1/4

54.9902.6040

⑰ Espresso-/Mokkalöffel / demi-tasse spoon

Länge	length
mm	in.
110	4 1/4

54.9901.6040

⑱ Sahnegießer / creamer

Mindestabnahme 6 Stück oder Vielfache /
minimum size of order 6 pieces or multiples

Höhe	height	Inhalt	cap.
cm	in.	Ltr.	oz.
3,4	1 1/4	0,02	0,7

06.3294.6040



**Sahne-/Zucker-Set
KaffeeKultur**

sugar and milk set
service pots à lait / sucriers
juego azucarero / cremera
set lattiera zuccheriera

bestehend aus: Tablett, Sahnekännchen und Zuckerbehälter /
consisting of: serving tray, creamer and sugar bowl

Cromargan®, Porzellan / stainless 18/10, porcelain

Unterteller / serving tray

Größe cm	size in.	
18,8 x 12 x 2	7 1/2 x 4 3/4 x 3/4	06.2500.6040

Sahnekännchen / creamer

Höhe cm	height in.	Inhalt Ltr.	cap. oz.	
7	2 3/4	0,08	2,7	55.0033.9990

Griff S / handle S **06.2509.6040**

Porzellantasse S / porcelain cup S

Höhe cm	height in.	Inhalt Ltr.	cap. oz.	
7,4	3	0,09	3,2	60.2508.9990

Ring S / ring S **06.2502.6040**

Deckel mit Ausschnitt / lid with cut-out **55.0031.6040**

Espresso-/Mokkalöffel / demi-tasse spoon **54.9901.6040**



**Deckel mit Ausschnitt
KaffeeKultur**

lid with cut-out
couverture avec découpe
tapa con recorte
coperchio con punto aperto per cucchiaino

passend zu Glas S, Porzellantasse S und Sahnekännchen von
KaffeeKultur. /
fitting for glass S, porcelain cup S and creamer of CoffeeCulture.

Cromargan® / stainless 18/10

Ø cm	Ø in.	
6	2 1/4	55.0031.6040



**Sahnekännchen
KaffeeKultur**

creamer
crémier
cremera
bricchetto per il latte

kombinierbar mit Ring S, Griff S, Deckel mit Ausschnitt oder
Eierbecher- / Teelicht-Aufsatz von KaffeeKultur /
to be combined with ring S, handle S, lid with cut-out or
tealight insert CoffeeCulture

Cromargan® / stainless 18/10

Höhe	height	Inhalt	cap.	
cm	in.	Ltr.	oz.	
7	2¾	0,08	2,7	55.0033.9990

Zubehör / accessory:

Ring S / ring S	06.2502.6040
Griff S / handle S	06.2509.6040
Deckel mit Ausschnitt / lid with cut-out	55.0031.6040
Eierbecher- / Teelicht-Aufsatz / egg cup / tealight insert	55.0032.6040



**Sahnekännchen, mit Deckel
KaffeeKultur**

creamer, with lid
crémier, avec couvercle
cremera, con tapa
bricchetto per il latte, con coperchio

Cromargan® / stainless 18/10

Sahnekännchen / creamer

Höhe	height	Inhalt	cap.	
cm	in.	Ltr.	oz.	
7	2¾	0,08	2,7	55.0033.9990

Griff S / handle S **06.2509.6040**

Deckel mit Ausschnitt / lid with cut-out **55.0031.6040**



**Porzellanbehälter
KaffeeKultur**

porcelain dish
récipient en porcelaine
recipiente de porcelana
recipiente di porcellana

für Zucker, Marmelade, Senf u.a. /
for sugar, jam, mustard ...

Cromargan®, Porzellan / stainless 18/10, porcelain

Porzellantasse S / porcelain cup S

Höhe	height	Inhalt	cap.	
cm	in.	Ltr.	oz.	
7,4	3	0,09	3,2	60.2508.9990

Ring S / ring S **06.2502.6040**

Deckel mit Ausschnitt / lid with cut-out **55.0031.6040**

Espresso-/Mokkalöffel / demi-tasse spoon **54.9901.6040**



Glasbehälter KaffeeKultur

glass dish
récipient en verre
recipiente de cristal
recipiente di vetro

für Zucker, Marmelade, Senf u.a. /
for sugar, jam, mustard ...

Cromargan®, Glas / stainless 18/10, glass

Glas S / glass S

Höhe cm	height in.	Inhalt Ltr.	cap. oz.
7,4	3	0,09	3,2

60.2506.9990

Ring S / ring S

06.2502.6040

Deckel mit Ausschnitt / lid with cut-out

55.0031.6040

Espresso-/Mokkalöffel / demi-tasse spoon

54.9901.6040



Eierbecher- / Teelicht-Aufsatz KaffeeKultur

egg cup / tealight insert
mise à coquetier / bougie
suplemento para huevera / vela
deposito por portauova / lumino

passend zu Glas S, Porzellantasse S und Sahnekännchen von
KaffeeKultur. Verwendbar für Eier oder Teelichte. /

fitting for glass S, porcelain cup S and creamer of CoffeeCulture. To use
for eggs or tealights.

Cromargan® / stainless 18/10

Ø cm	Ø in.
6	2 ¹ / ₄

55.0032.6040



Eierbecher / Teelicht / Vase KaffeeKultur

egg cup / tealight / vase
coquetier / bougie à chauffe-plat, porcelaine
huevera / candela, porcelana
portauovo / candela scaldavivande, porcellana

Porzellangefäß als Eierbecher, Vase oder Teelicht einsetzbar /
porcelain insert, to use as egg cup, flower vase or tealight holder

Cromargan® / stainless 18/10

Sahnekännchen / creamer

Höhe cm	height in.	Inhalt Ltr.	cap. oz.
7	2 ³ / ₄	0,08	2,7

55.0033.9990

Eierbecher- / Teelicht-Aufsatz /
egg cup / tealight insert

55.0032.6040

Ring S / ring S

06.2502.6040

Espresso-/Mokkalöffel / demi-tasse spoon

54.9901.6040



Kaffeekanne

coffee pot
cafetière
cafetera
caffettiera

doppelwandig /
double wall

Cromargan® / stainless 18/10

Höhe cm	height in.	Inhalt Ltr.	cap. oz.	
16	6 ¹ / ₄	0,3	10,14	55.0046.6040
20	7 ³ / ₄	0,6	20,28	55.0047.6040
25,5	10	1,2	40,56	55.0048.6040



Kaffeebereiter

coffee press
cafetière à piston
cafetera de émbolo
caffettiera con filtro

doppelwandig /
double wall

Cromargan® / stainless 18/10

Höhe cm	height in.	Inhalt Ltr.	cap. oz.	
20	7 ³ / ₄	0,6	20,28	55.0047.6041
25,5	10	1,2	40,56	55.0048.6041



Teekanne

tea pot
théière
tetera
teiera

doppelwandig /
double wall

Cromargan® / stainless 18/10

Höhe cm	height in.	Inhalt Ltr.	cap. oz.	
17	6 ³ / ₄	0,6	20,28	55.0050.6040
19,5	7 ³ / ₄	1,2	40,56	55.0051.6040



Teesieb

tea strainer
passoire à thé
interior colador tè
colino per tè

Cromargan® / stainless 18/10

Höhe cm	height in.	Ø cm	Ø in.	
9	3 ¹ / ₂	8,5*	3 ¹ / ₄ *	55.0053.6040
9	3 ¹ / ₂	10,7**	4 ¹ / ₄ **	55.0054.6040

* für Teekanne doppelwandig 0,6 l / for tea pot double wall 0,6 l

** für Teekanne doppelwandig 1,2 l / for tea pot double wall 1,2 l



Teesieb-Behälter

tea strainer holder
soucoupe pour passoire à thé
recipiente colador té
contenitore per colino tè

passend für die Siebe der doppelwandigen Teekannen /
fitting for the strainers of the double wall tea pots

Porzellan, weiß / porcelain, white

Höhe	height	Ø	Ø
cm	in.	cm	in.
8,2	3 ¹ / ₄	8	3 ¹ / ₄

55.0094.9990



Milchkanne

milk jug
pot à lait
lechera
lattiera

doppelwandig /
double wall

Cromargan® / stainless 18/10

Höhe	height	Inhalt	cap.
cm	in.	Ltr.	oz.
12,7	5	0,3	10,14

55.0055.6040



Kaffeekanne

URBAN

coffee pot
cafetière
cafetera
caffettiera

Höhe	height	Inhalt	cap.	Cromargan®	versilbert
cm	in.	Ltr.	oz.	stainless 18/10	silverplated
13,5	5 ¹ / ₄	0,3	10,14	06.3342.6041	19.3342.6441
15,5	6	0,5	16,9	06.3344.6041	19.3344.6441
20	7 ³ / ₄	1	33,8	06.3346.6041	19.3346.6441
23,5	9 ¹ / ₄	1,5	50,7	06.3347.6041	19.3347.6441



Teekanne

URBAN

tea pot
théière
tetera
teiera

Höhe	height	Inhalt	cap.	Cromargan®	versilbert
cm	in.	Ltr.	oz.	stainless 18/10	silverplated
12	4 ³ / ₄	0,3	10,14	06.3350.6041	19.3350.6441
14	5 ¹ / ₂	0,5	16,9	06.3351.6041	19.3351.6441



Milchkanne

URBAN

milk jug
pot à lait
lechera
lattiera

Höhe cm	height in.	Inhalt Ltr.	cap. oz.	Cromargan® stainless 18/10	versilbert silverplated
9,6	3 ³ / ₄	0,2	6,76	06.3360.6041	19.3360.6441
11,5	4 ¹ / ₂	0,3	10,14	06.3361.6041	19.3361.6441



Zuckerdose

URBAN

sugar basin
sucrier
azucarero
zuccheriera

Höhe cm	height in.	Inhalt Ltr.	cap. oz.	Cromargan® stainless 18/10	versilbert silverplated
7,4	3	0,25	8,45	06.3370.6041	19.3370.6441



Deckel zu Zuckerdose

URBAN

lid for sugar basin
couvercle pour sucrier
tapa para azucarero
coperchio per zuccheriera

Höhe cm	height in.	Cromargan® stainless 18/10	versilbert silverplated
1,5	1/2	06.3370.6042	19.3370.6442



Kaffeekanne

CLASSIC

coffee pot
cafetière
cafetera
caffettiera

Höhe cm	height in.	Inhalt Ltr.	cap. oz.	Cromargan® stainless 18/10	versilbert silverplated
13,5	5 ¹ / ₄	0,3	11	06.3501.6040	19.3501.6440
17	6 ³ / ₄	0,6	21	06.3502.6040	19.3502.6440
22	8 ³ / ₄	1,5	53	06.3504.6040	19.3504.6440
25,5	10	2	70	06.3509.6040	



**Teekanne
CLASSIC**

tea pot
théière
tetera
teiera

Höhe cm	height in.	Inhalt Ltr.	cap. oz.	Cromargan® stainless 18/10	versilbert silverplated
11	4 ¹ / ₄	0,3	11	06.3506.6040	19.3506.6440
14,5	5 ³ / ₄	0,55	19	06.3507.6040	19.3507.6440
17,5	7	1,25	44	06.3508.6040	19.3508.6440



**Milchkanne
CLASSIC**

milk jug
pot à lait
lechera
lattiera

Höhe cm	height in.	Inhalt Ltr.	cap. oz.	Cromargan® stainless 18/10	versilbert silverplated
8,5	3 ¹ / ₂	0,15	5	06.3512.6040	19.3512.6440
11	4 ¹ / ₄	0,3	11	06.3513.6040	19.3513.6440
13,5	5 ¹ / ₂	0,6	21	06.3514.6040	19.3514.6440



**Zuckerdose
CLASSIC**

sugar basin
sucrier
azucarero
zuccheriera

Höhe cm	height in.	Inhalt Ltr.	cap. oz.	Cromargan® stainless 18/10	versilbert silverplated
7	2 ³ / ₄	0,25	8,8	06.3519.6040	19.3519.6440



**Zuckerdose, mit Deckel
CLASSIC**

sugar basin, with cover
sucrier, avec couvercle
azucarero, con tapa
zuccheriera, con coperchio

Höhe cm	height in.	Inhalt Ltr.	cap. oz.	Cromargan® stainless 18/10	versilbert silverplated
9,5	3 ³ / ₄	0,15	5,3	06.3520.6040	19.3520.6440
12	4 ³ / ₄	0,25	8,8	06.3521.6040	19.3521.6440



Kaffeekanne

SCALA

coffee pot
cafetière
cafetera
caffettiera

Deckel komplett zu öffnen, geringe Wärmeübertragung am Griff /
cover to be opened completely, slight heat transfer at the handle

Höhe cm	height in.	Inhalt Ltr.	cap. oz.	Cromargan® stainless 18/10	versilbert silverplated
14,5	5 ³ / ₄	0,3	11	06.3700.6041	19.3700.6441
17	6 ³ / ₄	0,6	21	06.3701.6041	19.3701.6441
25,5	10	1,9	67	06.3702.6041	19.3702.6441



Teekanne

SCALA

tea pot
théière
tetera
teiera

Deckel komplett zu öffnen, geringe Wärmeübertragung am Griff /
cover to be opened completely, slight heat transfer at the handle

Höhe cm	height in.	Inhalt Ltr.	cap. oz.	Cromargan® stainless 18/10	versilbert silverplated
13	5 ¹ / ₄	0,3	11	06.3703.6041	19.3703.6441
15,5	6 ¹ / ₄	0,6	21	06.3704.6041	19.3704.6441



Milchkanne

SCALA

milk jug
pot à lait
lechera
lattiera

Höhe cm	height in.	Inhalt Ltr.	cap. oz.	Cromargan® stainless 18/10	versilbert silverplated
9,5	3 ³ / ₄	0,15	5	06.3710.6041	19.3710.6441
14,5	4 ³ / ₄	0,3	11	06.3711.6041	19.3711.6441



Zuckerdose

SCALA

sugar basin
sucrier
azucarero
zuccheriera

Höhe cm	height in.	Inhalt Ltr.	cap. oz.	Cromargan® stainless 18/10	versilbert silverplated
8,5	3 ¹ / ₂	0,25	9	06.3720.6040	19.3720.6440

Deckel zu Zuckerdose SCALA

lid for sugar basin
couvercle pour sucrier
tapa para azucarero
coperchio per zuccheriera



passend zur Zuckerdose SCALA 06.3720.6040 /
fitting for sugar basin SCALA 06.3720.6040

Höhe cm	height in.	Cromargan® stainless 18/10	versilbert silverplated
2,5	1	06.3720.6041	19.3720.6441

Isolierkanne

coffee pot insulated
cafetière thermos
cafetera termo
caffettiera termica



doppelwandig, schaumisoliert /
double wall, insulating foam cushion

Cromargan® / stainless 18/10

Höhe cm	height in.	Inhalt Ltr.	cap. oz.	
19	7½	0,3	11	06.8300.6040
21	8¼	0,6	21	06.8301.6040
26	10¼	1	35	06.8307.6040

Kaffeekanne PURE

coffee pot
cafetière
cafetera
caffettiera



stapelbar /
stackable

Cromargan®, teilmattiert /
stainless 18/10, partly satin finished

Höhe cm	height in.	Inhalt Ltr.	cap. oz.	
11,5	4½	0,3	11	06.3801.6040
14	5½	0,6	21	06.3808.6040
20	8	1,9	66,5	06.3809.6040



Teekanne

PURE

tea pot
théière
tetera
teiera

stapelbar /
stackable

Cromargan®, teilmattiert /
stainless 18/10, partly satin finished

Höhe cm	height in.	Inhalt Ltr.	cap. oz.	
9,5	3 ³ / ₄	0,3	11	06.3802.6040
11,5	4 ¹ / ₂	0,6	21	06.3810.6040



Sahnegießer

PURE

creamer
crémier
cremera
cremiera

Cromargan®, teilmattiert /
stainless 18/10, partly satin finished

Höhe cm	height in.	Inhalt Ltr.	cap. oz.	
5	2	0,03	1,1	06.3807.6040



Sahnegießer

creamer
crémier
cremera
cremiera

Mindestabnahme 6 Stück oder Vielfache /
minimum size of order 6 pieces or multiples

Cromargan® / stainless 18/10

Höhe cm	height in.	Inhalt Ltr.	cap. oz.	
3,4	1 ¹ / ₄	0,02	0,7	06.3294.6040



Zuckerteller

small plate for packed sugar
coupe à sucre
platito azúcar
piattino per zucchero

Cromargan® / stainless 18/10

Ø cm	Ø in.			
6	2 ¹ / ₄			06.3277.6040



Zuckerdosierer

sugar dispenser
saupoudreuse à sucre
dosificador azúcar
versazucchero

Cromargan® / stainless 18/10

Höhe	height	Inhalt	cap.
cm	in.	Ltr.	oz.
15	6	0,3	10,5

06.3230.6040

Ersatzteil / spare part:

Kunststoffeinsatz (10 St.) / plastic insert (10 pcs.)

08.0025.1000

Ersatzglas / spare glass

19.9999.8613



Zuckerdosierer

sugar dispenser
saupoudreuse à sucre
dosificador azúcar
versazucchero

Cromargan®, Glas / stainless 18/10, glass

Höhe	height	Inhalt	cap.
cm	in.	Ltr.	oz.
15,5	6	0,24	8,4

06.3661.6040

Ersatzteil / spare part:

Ersatzglas / spare glass

60.8294.9990



Honig-/Sahnepender

honey/cream dispenser
distributeur à miel / crème
dispensador miel / nata
versamiele / versalette

Cromargan®, Glas / stainless 18/10, glass

Höhe	height	Inhalt	cap.
cm	in.	Ltr.	oz.
15,5	6	0,24	8,4

06.3664.6040

Ersatzteil / spare part:

Ersatzglas / spare glass

60.8294.9990



Zuckergestell, 4tlg. CLASSIC

sugar server, set of 4
service à sucre, en 4 parties
servicio de azúcar, 4 piezas
zuccheriera, a 4 vaschette

Höhe	height
cm	in.
21	8 1/4

Cromargan® versilbert
stainless 18/10 silverplated
06.3186.6040 19.3186.6440

Ersatzteil / spare part:

Porzellaneinsatz / porcelain insert

60.3099.9990



Serviertablett für Zucker

sugar bowl serving tray
 plateau de service pour sucre
 bandeja con azucareros
 vassoio per zucchero

Tablett, oval / serving tray, oval

Größe	size		
cm	in.		
22 x 15,5	8 ³ / ₄ x 6		

Cromargan®	versilbert
stainless 18/10	silverplated
06.7540.6040	19.7540.6440

Zuckerdose / sugar bowl

Inhalt	cap.	Ø	Ø
Ltr.	oz.	cm	in.
0,1	3,5	6	2 ¹ / ₄

Cromargan®	versilbert
stainless 18/10	silverplated
06.3752.6040	19.3752.6440



Milch-Zucker-Set CLASSIC

sugar and creamer set
 service pots à lait / sucriers
 juego azucarero / cremera
 set lattiera zuccheriera

versilbert / silverplated

Höhe	height
cm	in.
22	8 ³ / ₄

19.3175.6440

Ersatzteil / spare part:

Milchkanne / milk jug

19.3719.6440

Inhalt	cap.
Ltr.	oz.
0,15	5,3

Zuckerdose / sugar bowl

19.3752.6440

Inhalt	cap.	Ø	Ø
Ltr.	oz.	cm	in.
0,1	3,5	6	2 ¹ / ₄

Zuckerdose, mit Deckel / sugar bowl, with lid

19.3753.6440

Inhalt	cap.	Ø	Ø
Ltr.	oz.	cm	in.
0,10	3,5	6	2 ¹ / ₄



Milch-Zucker-Set CLASSIC

sugar and creamer set
 service pots à lait / sucriers
 juego azucarero / cremera
 set lattiera zuccheriera

versilbert / silverplated

Höhe	height
cm	in.
18,5	7 ¹ / ₄

19.3174.6440

Ersatzteil / spare part:

Milchkanne / milk jug

19.3719.6440

Inhalt	cap.
Ltr.	oz.
0,15	5,3

Zuckerdose, mit Deckel / sugar bowl, with lid

19.3753.6440

Inhalt	cap.	Ø	Ø
Ltr.	oz.	cm	in.
0,10	3,5	6	2 ¹ / ₄



Milch-Zucker-Set CLASSIC

sugar and creamer set
service pots à lait / sucriers
juego azucarero / cremera
set lattiera zuccheriera

Höhe	height
cm	in.
18,5	7 1/4

Cromargan®	versilbert
stainless 18/10	silverplated
06.3185.6040	19.3185.6440

Ersatzteil / spare part:

Milchkanne / milk jug	06.3415.6040
-----------------------	--------------

Höhe	height	Inhalt	cap.
cm	in.	Ltr.	oz.
8	3 1/4	0,15	5,3

Zuckerdose / sugar bowl	06.3752.6040
-------------------------	--------------

Inhalt	cap.	Ø	Ø
Ltr.	oz.	cm	in.
0,1	3,5	6	2 1/4

Milchkanne / milk jug	19.3415.6440
-----------------------	--------------

Höhe	height	Inhalt	cap.
cm	in.	Ltr.	oz.
8	3 1/4	0,15	5,3

Zuckerdose / sugar bowl	19.3752.6440
-------------------------	--------------

Inhalt	cap.	Ø	Ø
Ltr.	oz.	cm	in.
0,1	3,5	6	2 1/4



Sahne-Zucker-Set PURE

sugar and creamer set
service pots à lait / sucriers
juego azucarero / cremera
set lattiera zuccheriera

bestehend aus: Gestell, Sahnekännchen, Löffel, Zuckerdose /
consisting of: stand, cream dispenser, spoon, sugar dispenser

Cromargan®, teilmattiert /
stainless 18/10, partly satin finished

Höhe	height	Inhalt	cap.
cm	in.	Ltr.	oz.
18	7	0,2	7

06.3804.6040

Ersatzteil / spare part:

Milchkännchen / creamer	06.3806.6040
-------------------------	--------------

Zuckerdose / sugar basin	06.3805.6040
--------------------------	--------------

Löffel / spoon	12.9102.6040
----------------	--------------



**Sahne-Zucker-Set
PURE**

sugar and creamer set
service pots à lait / sucriers
juego azucarero / cremera
set lattiera zuccheriera

bestehend aus: Gestell, Sahnekännchen, Zuckerstangengefäß /
consisting of: stand, cream dispenser, sugar pack holder

Cromargan®, teilmattiert /
stainless 18/10, partly satin finished

Höhe cm	height in.	Inhalt Ltr.	cap. oz.
18	7	0,2	7

06.3803.6040

Ersatzteil / spare part:

Milchkännchen / creamer

06.3806.6040

Zuckerstangengefäß / sugar pack holder

06.7120.6040



**Sahne-Zucker-Set
PURE**

sugar and milk set
service pots à lait / sucriers
juego azucarero / cremera
set lattiera zuccheriera

bestehend aus Gestell, 2x Zuckerbehälter Glas und Sahnekännchen
Porzellan /
consisting of: stand, 2x sugar bowl glass and creamer porcelain

Cromargan®, Glas, Porzellan / stainless 18/10, glass, porcelain

Gestell nieder / stand low

Höhe cm	height in.	Ø cm	Ø in.
16	6 1/4	14	5 1/2

06.2340.6045

Glas S / glass S

Höhe cm	height in.	Inhalt Ltr.	cap. oz.
7,4	3	0,09	3,2

60.2506.9990

Ring S / ring S

06.2502.6040

Deckel mit Ausschnitt / lid with cut-out

55.0031.6040

Sahnekännchen / creamer

Höhe cm	height in.	Inhalt Ltr.	cap. oz.
7	2 3/4	0,08	2,7

55.0033.9990

Griff S / handle S

06.2509.6040

Espresso-/Mokkalöffel / demi-tasse spoon

54.9901.6040



Milch-Zucker-Set, 3tlg.

PURE

sugar and milk set, set of 3
 service pots à lait / sucriers, en 3 parties
 juego azucarero / cremera, 3 piezas
 set lattiera zuccheriera, a 3 vaschette

bestehend aus: Gestell, 2x Zuckerbehälter, 1 Sahnekännchen /
 consisting of: stand, 2x sugar bowl, 1 milk pot

Cromargan® / stainless 18/10

Höhe	height	Ø	Ø
cm	in.	cm	in.
16,1	6 1/2	14	5 1/2

06.2340.6040

Ersatzteil / spare part:

Zuckerdose, mit Deckel / sugar basin, with cover

06.2342.6040

Höhe	height	Inhalt	cap.	Ø	Ø
cm	in.	Ltr.	oz.	cm	in.
5,2	2	0,1	3,5	6	2 1/4

Gestell nieder / stand low

06.2340.6045

Höhe	height	Ø	Ø
cm	in.	cm	in.
16	6 1/4	14	5 1/2

Milchkännchen / creamer

06.3806.6040

Höhe	height	Inhalt	cap.
cm	in.	Ltr.	oz.
8,5	3 1/4	0,2	7



Zuckergestell, 4tlg.

PURE

sugar set, 4 pcs.
 service à sucriers, 4 parties
 juego azucarero, 4 piezas
 set zuccheriera, a 4vaschette

bestehend aus: Gestell, 4x Zuckerbehälter /
 consisting of: stand, 4 sugar bowls

Cromargan® / stainless 18/10

Höhe	height	Ø	Ø
cm	in.	cm	in.
16,1	6 1/2	14	5 1/2

06.2339.6040

Ersatzteil / spare part:

Gestell nieder / stand low

06.2340.6045

Höhe	height	Ø	Ø
cm	in.	cm	in.
16	6 1/4	14	5 1/2

Porzellaneinsatz / porcelain insert

60.3099.9990



**Milch-Zucker-Set
PURE EXCLUSIV**

sugar and milk set
service pots à lait / sucriers
juego azucarero / cremera
set lattiera zuccheriera

Mit 3 Einsätzen für wahlweise Gläser S, Tassen S (o. Abb.) oder Sahnekännchen mit oder ohne Deckel von KAFFEEKULTUR. Nicht spülmaschinengeeignet! /
With 3 inserts alternatively for glasses S, cups S (w/o pic.) or creamer with or w/o lid of CoffeeCulture. Not dishwasher-safe!

Cromargan®, Holz dunkel gebeizt /
stainless 18/10, wood dark stained

Teelichtleuchter 3fl. klein / tealight candle stick, small

Größe	size	
cm	in.	
20,5 x 6,2 x 3,7	8 x 2 ¹ / ₂ x 1 ¹ / ₂	55.0039.6040

Glas S / glass S

Höhe	height	Inhalt	cap.	
cm	in.	Ltr.	oz.	
7,4	3	0,09	3,2	60.2506.9990

Sahnekännchen / creamer

Höhe	height	Inhalt	cap.	
cm	in.	Ltr.	oz.	
7	2 ³ / ₄	0,08	2,7	55.0033.9990

Deckel mit Ausschnitt / lid with cut-out

55.0031.6040

Espresso-/Mokkalöffel / demi-tasse spoon

54.9901.6040



**Milch-Zucker-Set, 4tlg.
PURE EXCLUSIV**

sugar and milk set, set of 4
service pots à lait / sucriers, en 4 parties
juego azucarero / cremera, 4 piezas
set lattiera zuccheriera, a 4 vaschette

Gestell mit 4 Einsätzen für Gläser S oder Tassen S (o.Abb.), mit oder ohne Deckel von KAFFEEKULTUR, Sahnekännchen und Zuckerstangengefäß von PURE. Nicht spülmaschinengeeignet! /
stand with 4 inserts for glasses S or cups S (w/o pic.), with or w/o lid of CoffeeCulture or creamer and sugar pack holder of PURE. Not dishwasher-safe!

Cromargan®, Holz dunkel gebeizt /
stainless 18/10, wood dark stained

Menage / stand

Größe	size	
cm	in.	
14,5 x 14,5 x 25,4	5 ³ / ₄ x 5 ³ / ₄ x 10	55.0034.6040

Glas S / glass S

Höhe	height	Inhalt	cap.	
cm	in.	Ltr.	oz.	
7,4	3	0,09	3,2	60.2506.9990

Porzellantasse S / porcelain cup S

Höhe	height	Inhalt	cap.	
cm	in.	Ltr.	oz.	
7,4	3	0,09	3,2	60.2508.9990

Deckel mit Ausschnitt / lid with cut-out

55.0031.6040

Espresso-/Mokkalöffel / demi-tasse spoon

54.9901.6040

Milchkännchen / creamer

Höhe	height	Inhalt	cap.	
cm	in.	Ltr.	oz.	
8,5	3 ¹ / ₄	0,2	7	06.3806.6040

Zuckerstangengefäß / sugar pack holder

Höhe	height	Ø	Ø	
cm	in.	cm	in.	
8,5	3 ¹ / ₄	6	2 ¹ / ₄	06.7120.6040

Milch-Zucker-Set, 4tlg.

PURE EXCLUSIV

sugar and milk set, set of 5
 service pots à lait / sucriers, en 4 parties
 juego azucarero / cremera, 4 piezas
 set lattiera zuccheriera, a 4 vaschette

Gestell mit 4 Einsätzen für Gläser S oder Tassen S (o.Abb.), mit oder ohne Deckel von KAFFEEKULTUR, Sahnekännchen und Zuckerdose von PURE. Nicht spülmaschinengeeignet! / stand with 4 inserts for glasses S or cups S (w/o pic.), with or w/o lid of CoffeeCulture or creamer and sugar basin of PURE. Not dishwasher-safe!

Cromargan®, Holz dunkel gebeizt / stainless 18/10, wood dark stained



Menage / stand

Größe cm	size in.	
14,5 x 14,5 x 25,4	5 ³ / ₄ x 5 ³ / ₄ x 10	55.0034.6040

Glas S / glass S

Höhe cm	height in.	Inhalt Ltr.	cap. oz.	
7,4	3	0,09	3,2	60.2506.9990

Porzellantasse S / porcelain cup S

Höhe cm	height in.	Inhalt Ltr.	cap. oz.	
7,4	3	0,09	3,2	60.2508.9990

Deckel mit Ausschnitt / lid with cut-out

55.0031.6040

Espresso-/Mokkalöffel / demi-tasse spoon

54.9901.6040

Milchkännchen / creamer

Höhe cm	height in.	Inhalt Ltr.	cap. oz.	
8,5	3 ¹ / ₄	0,2	7	06.3806.6040

Zuckerdose, mit Deckel / sugar basin, with cover

Höhe cm	height in.	Inhalt Ltr.	cap. oz.	Ø cm	Ø in.	
5,2	2	0,1	3,5	6	2 ¹ / ₄	06.2342.6040

Zuckerdose

PURE

sugar basin
 sucrier
 azucarero
 zuccheriera

Cromargan®, teilmattiert / stainless 18/10, partly satin finished



Höhe cm	height in.	Inhalt Ltr.	cap. oz.	
8,5	3 ¹ / ₄	0,2	7	06.3805.6040



Zuckerdose, mit Deckel

PURE

sugar basin, with cover
sucrier, avec couvercle
azucarero, con tapa
zuccheriera, con coperchio

Cromargan®, teilmattiert /
stainless 18/10, partly satin finished

Höhe	height	Inhalt	cap.	Ø	Ø	
cm	in.	Ltr.	oz.	cm	in.	
5,2	2	0,1	3,5	6	2 1/4	06.2342.6040



Zuckerstangengefäß

PURE

sugar pack holder
service pots à lait / sucriers, en 4 parties
azucarero para azúcar en cañas
set lattiera zuccheriera, a 4 vaschette

stapelbar /
stackable

Cromargan®, teilmattiert /
stainless 18/10, partly satin finished

Höhe	height	Ø	Ø	
cm	in.	cm	in.	
8,5	3 1/4	6	2 1/4	06.7120.6040



Milchkännchen

PURE

creamer
service pots à lait / sucriers, en 4 parties
cremera
set lattiera zuccheriera, a 4 vaschette

Cromargan®, teilmattiert /
stainless 18/10, partly satin finished

Höhe	height	Inhalt	cap.	
cm	in.	Ltr.	oz.	
8,5	3 1/4	0,2	7	06.3806.6040



Zahnstocher- und Süßstoffbehälter

PURE

toothpick- and sweetener box-holder
porte-cure-dents et récipient pour sucrettes
palillero y dispensador de edulcorante
porta stuzzicadenti e contenitore per dolcificante

zum Einhängen in alle WMF PURE-Gestelle mit Bügelgriff.
Laser-Gravur der Tischnummer nach Wunsch - Preis auf Anfrage /
fitting in all racks of WMF PURE sets. Engraving of the table No. on
request - please ask for respective costs

Cromargan® / stainless 18/10

Höhe	height	
cm	in.	
4	1 1/2	06.1905.6044



Kaffeetablett

PURE

serving tray
plateau de service
bandeja
vassoio

stapelbar, oval /
stackable, oval

Cromargan® / stainless 18/10

Größe	size
cm	in.
27 x 17	10 ¹ / ₂ x 6 ³ / ₄

06.7550.6040



Porzellanschale, 3-geteilt

PURE

porcelain bowl 3-section
coupe en porcelaine 3 parties
cuenco de porcelana 3 divisiones
vassoietto tripartito portazzucchero

mit 2 Unterteilungen für Tee, Zucker oder Antipasti /
with 2 partitions for tea, sugar or Antipasti

Porzellan weiß / porcelain white

Größe	size
cm	in.
21 x 8,7 x 3,25	8 ¹ / ₄ x 3 ¹ / ₂ x 1 ¹ / ₄

60.3538.9990



Zubehör / accessory:

Tablett, oval / serving tray, oval

06.7551.6040

Größe	size
cm	in.
24,5 x 12	9 ¹ / ₂ x 4 ³ / ₄



Tablett, oval

serving tray, oval
plateau de service, ovale
bandeja, oval
vassoio, ovale

Größe	size
cm	in.
22 x 15,5	8 ³ / ₄ x 6
27 x 20	10 ¹ / ₂ x 8
29 x 22,5	11 ¹ / ₂ x 8 ³ / ₄

Cromargan®	versilbert
stainless 18/10	silverplated
06.7540.6040	19.7540.6440
06.7542.6040	19.7542.6440
06.7543.6040	19.7543.6440



Latte Macchiato-Set

Latte Macchiato Set
latte-macchiato-set
juego latte macchiato
set latte-macchiato

12er Set bestehend aus:
12 x Glas, 12 x Löffel, 12 x Unterteller (Durchm. 12 cm) /
set of 12 pcs. consisting of:
12 x glass, 12 x spoon, 12 x underliner (dia. 4³/₄ in.)

Cromargan®, Glas / stainless 18/10, glass

Inhalt	cap.
Ltr.	oz.
0,3	10,5

06.3172.6040

Ersatzteil / spare part:

Unterteller / underliner	06.3612.6040
Eiskaffeeelöffel / iced tea spoon	12.9188.6040
6er Set Gläser / 6 glasses	19.9999.8667



Gläser-Set, Iced Coffee - Set

glass set, iced coffee set
set à glass
juego vasos
set da bicchieres

6er Set bestehend aus: 6 x Glas, 6 x Löffel, 6 x Unterteller (18,8 x 12 cm) /
set of 6 pcs. consisting of: 6 x glass, 6 x spoon, 6 x underliner (18,8 x 12 cm / 7 1/2 x 4 3/4 in.)

Cromargan®, Glas / stainless 18/10, glass

55.0090.6040

Ersatzteil / spare part:

Ersatzglas, (6 St.) / spare glasses, (6 pcs.) 55.0089.9990

Inhalt	cap.
Ltr.	oz.
0,3	10,5

Unterteller / serving tray	06.2500.6040
Muglöffel / mug spoon	54.9903.6040



Glas-Set LATTE, (6 St.)

glass set LATTE, (6 pcs.)
set à glass LATTE, (6 pc.)
juego vasos LATTE, (6 p.)
set da bicchieres LATTE, (6 p.)

Gläser bedruckt mit „LATTE“ /
glasses printed with „LATTE“

Höhe	height	Inhalt	cap.	Ø	Ø
cm	in.	Ltr.	oz.	cm	in.
14,5	5 ³ / ₄	0,35	11,62	6,5	2 ¹ / ₂

55.0092.9990



Teeglas PURE

tea glass
verre à thé
vaso té
bicchiere da té

Cromargan®, Glas / stainless 18/10, glass

Höhe	height	Inhalt	cap.	Ø	Ø	
cm	in.	Ltr.	oz.	cm	in.	
9	3 1/2	0,2	6,76	6,5	2 1/2	06.3565.6040

Ersatzteil / spare part:

Glaseinsatz / glass insert 60.3147.9990



Teesieb-Behälter

tea strainer holder
soucoupe pour passoire à thé
recipiente colador té
contenitore per colino tè

für Teesieb-Einsatz 06.3428.6030 /
fitting for tea strainer insert 06.3428.6030

Porzellan, weiß / porcelain, white

Höhe	height	Ø	Ø	
cm	in.	cm	in.	
8	3 1/4	5	2	60.3039.9990



Teesieb-Einsatz

tea strainer insert
passoire à thé
interior colador té
colino per tè

passend in alle WMF-Teekannen /
fitting in all WMF tea pots

Cromargan® / stainless 18/10

Höhe	height	Ø	Ø	
cm	in.	cm	in.	
7	2 3/4	5	2	06.3428.6030



Teesieb, mit Abtropfschale

tea strainer, with bowl
passoire, avec réceptacle à thé
recipiente colador, de té con bandejita escurridora
colino per tè con vaschetta raccogliocce

Höhe	height	Größe	size	Cromargan®	versilbert
cm	in.	cm	in.	stainless 18/10	silverplated
3	1 1/4	12 x 9,5	4 3/4 x 3 3/4	06.3327.6040	19.3327.6440



Zitronenpresse, 6er Set

lemon/orange squeezer, set of 6
presse-citron, en 6 parties
exprimidor para limones, 6 piezas
spremilimone, a 6 vaschette

Cromargan® mattiert / stainless 18/10, satin finished

06.8221.6030

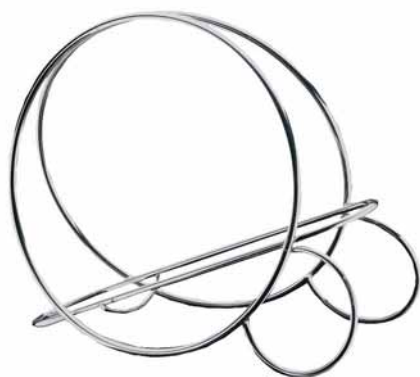
**Rotweinwiege**

red wine cradle
porte-bouteille
portabotellas
versavino

für Flasche 0,75 Ltr. /
for bottle 26,3 oz.

Cromargan® / stainless 18/10

06.8045.5080

**Weinkorb**

wine-basket
panier à vin
cesta vino
cestino portavino

versilbert / silverplated

Höhe	height	Größe	size	
cm	in.	cm	in.	
17,5	7	23,5 x 10	9 1/4 x 4	19.2379.6440

**Punchbowl
CLASSIC**

punch bowl
bol à punch
ponchera
bowl per punch

Cromargan® / stainless 18/10

Höhe	height	Inhalt	cap.	Ø	Ø	
cm	in.	Ltr.	oz.	cm	in.	
29	11 1/2	10	350	38,5	15 1/4	06.0446.6040
40	15 3/4	37	1295	56	22	06.0494.6040

versilbert / silverplated

Höhe	height	Inhalt	cap.	Ø	Ø	
cm	in.	Ltr.	oz.	cm	in.	
29	11 1/2	10	350	38,5	15 1/4	19.0446.6440

**Punchbowl
PURE**

punch bowl
bol à punch
ponchera
bowl per punch

Cromargan® / stainless 18/10

Höhe	height	Ø	Ø	
cm	in.	cm	in.	
27	10 3/4	38	15	06.0471.6040



Punchbowl NEUTRAL

punch bowl
bol à punch
ponchera
bowl per punch

Cromargan® / stainless 18/10

Höhe	height	Inhalt	cap.	Ø	Ø	
cm	in.	Ltr.	oz.	cm	in.	
29	11½	10	350	38,5	15¼	06.0449.6040



Glasschüssel für Punchbowl

glass insert for punch bowl
intérieur verre pour bol à punch
interior cristal, adaptable a la ponchera
interno in vetro per bowl

passend zu Punchbowl Ø 38,5 und 42,5 cm /
fitting for punch bowl Ø 15¼ in. and 16¾ in.

Höhe	height	Inhalt	cap.	Ø	Ø	
cm	in.	Ltr.	oz.	cm	in.	
16,6	6½	5	176	31,5	12½	19.9999.8640



Ring für Glasschüssel

ring for glass insert
anneau pour intérieur verre
anilla para interior de cristal
anello per interno in vetro

passend zu Punchbowl Ø 38,5 und 42,5 cm /
fitting for punch bowl Ø 15¼ in. and 16¾ in.

Cromargan® / stainless 18/10

Höhe	height	Ø	Ø	
cm	in.	cm	in.	
13	5	33	13	06.0447.6010



Gläser-/Flaschenring

glass ring
anneau (porte verre)
anilla para ponchera
anello per bicchieri e bottiglie

passend zu Punchbowl Ø 38,5 und 42,5 cm /
fitting for punch bowl Ø 15¼ in. and 16¾ in.

Cromargan® / stainless 18/10

Höhe	height	Ø	Ø	
cm	in.	cm	in.	
10	4	33	13	06.0442.6010



Gläser-/Flaschenring

glass ring
anneau (porte verre)
anilla para ponchera
anello per bicchieri e bottiglie

passend zu Punchbowl Ø 38,5 und 42,5 cm /
fitting for punch bowl Ø 15¹/₄ in. and 16³/₄ in.

Cromargan® / stainless 18/10

Höhe	height	Ø	Ø
cm	in.	cm	in.
10	4	33	13

06.0428.6010



Wein-/Sektküher CLASSIC

wine / champagne cooler
seau à vin / champagne
cubo vino / champán
rinfrescavino / spumante

oval, für 2 Flaschen, passend in Weinkühlerständer mit Durchm. mind.
22,5 cm /
oval, for 2 bottles, fitting in stand for wine/champagne with dia.
22,5 cm minimum

Höhe	height	Cromargan®	versilbert
cm	in.	stainless 18/10	silverplated
20,6	8	06.8191.6040	19.8191.6440



Wein-/Sektküher CLASSIC

wine / champagne cooler
seau à vin / champagne
cubo vino / champán
rinfrescavino / spumante

passend in Weinkühlerständer mit Durchmesser mind. 15 cm /
fitting in stand for wine/champagne cooler with dia. 15 cm minimum

rund /
round

Höhe	height	Cromargan®	versilbert
cm	in.	stainless 18/10	silverplated
20,8	8 ¹ / ₄	06.8190.6040	19.8190.6440



Wein-/Sektküher CLASSIC

wine / champagne cooler
seau à vin / champagne
cubo vino / champán
rinfrescavino / spumante

rund, für 2 Flaschen. Passend in Weinkühlerständer mit Durchm. mind.
20 cm /
round, for 2 bottles. Fitting in stand for wine/champagne with dia.
20 cm minimum

Cromargan® / stainless 18/10

Höhe	height
cm	in.
23,5	9 ¹ / ₄

06.8051.6040

**Wein-/Sektküher****PURE**

wine / champagne cooler
 seu à vin / champagne
 cubo vino / champán
 rinfrescavino / spumante

rund. Passend in Weinkühlerständer mit Durchm. mind. 16 cm /
 round. Fitting in stand for wine/champagne with dia. 16 cm minimum

Cromargan® / stainless 18/10

Höhe	height	Ø	Ø
cm	in.	cm	in.
22	8 ³ / ₄	19	7 ¹ / ₂

06.0469.6040

**Wein-/Sektküher****PURE**

wine / champagne cooler
 seu à vin / champagne
 cubo vino / champán
 rinfrescavino / spumante

rund. Passend in Weinkühlerständer mit Durchm. mind. 16,5 cm /
 round. Fitting in stand for wine/champagne with dia. 16,5 cm minimum

Cromargan® teilmattiert / stainless 18/10 partly satin finished

Höhe	height
cm	in.
20,5	8

06.8195.6040

**Weinkühler****URBAN**

wine / champagne cooler
 seu à vin / champagne
 subo vino / champán
 rinfrecavino / spumante

doppelwandig. Passend in Weinkühlerständer mit Durchm. mind.
 16 cm. /
 double wall. Fitting in stand for wine/champagne with dia. 16 cm
 minimum.

Cromargan® / stainless 18/10

Höhe	height	Ø	Ø
cm	in.	cm	in.
24	9 ¹ / ₂	16	6 ¹ / ₄

55.0064.6040

**Wein-/Sektküher****NEUTRAL**

wine / champagne cooler
 seu à vin / champagne
 cubo vino / champán
 rinfrescavino / spumante

rund. Passend in Weinkühlerständer mit Durchm. mind. 16 cm /
 round. Fitting in stand for wine/champagne with dia. 16 cm minimum

Cromargan® / stainless 18/10

Höhe	height
cm	in.
20,8	8 ¹ / ₄

06.8019.6040



Weinkühler

wine cooler
seau à vin
cubo vino
rinfrescavino

doppelwandig. Passend in Weinkühlerständer mit Durchm. mind.
12,5 cm /
double wall. Fitting in stand for wine/champagne with dia. 12,5 cm
minimum

Cromargan® mattiert / stainless 18/10, satin finished

Höhe	height	Ø	Ø
cm	in.	cm	in.
19,5	7 ³ / ₄	12	4 ³ / ₄

06.8239.6040

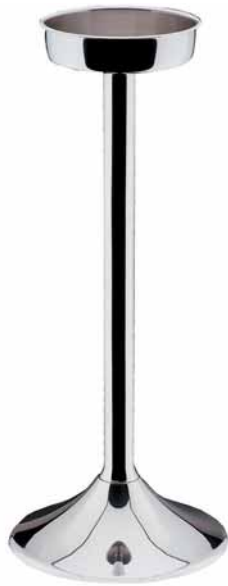

Weinkühlerständer

NEUTRAL

stand for wine/champagne cooler
support pour seau à champagne
portacubos champán
colonna per secchio spumante

rund /
round

Höhe	height	Ø Schale	dish Ø	Cromargan®	versilbert
cm	in.	cm	in.	stainless 18/10	silverplated
60	23 ¹ / ₂	16	6 ¹ / ₄	06.8337.6040	19.8337.6440

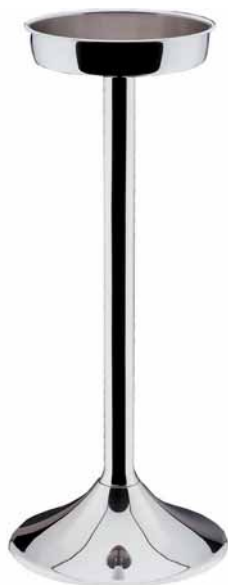

Weinkühlerständer

NEUTRAL

stand for wine/champagne cooler
support pour seau à champagne
portacubos champán
colonna per secchio spumante

rund /
round

Cromargan® / stainless 18/10

Höhe	height	Ø Schale	dish Ø
cm	in.	cm	in.
60	23 ¹ / ₂	20	8

06.8452.6040

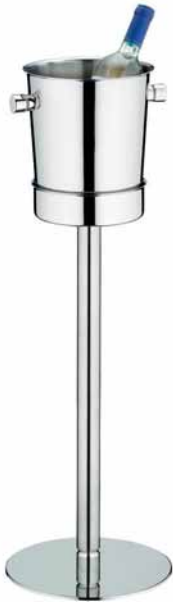

Weinkühlerständer

PURE

stand for wine/champagne cooler
support pourseau à champagne
portacubos champán
colonna per secchio spumante

rund /
round

Cromargan® / stainless 18/10

Höhe cm	height in.	Ø cm	Ø in.	Ø Schale cm	dish Ø in.	
68,8	27	25	9 ³ / ₄	16	6 ¹ / ₄	06.0468.6040



Flaschenteller

CLASSIC

coaster for bottles
dessous de bouteille
portabotella
sottobottiglia

Ø Schale cm	dish Ø in.
10,5	4 ¹ / ₄

Cromargan® versilbert
stainless 18/10 silverplated
06.2177.6040 19.2177.6440



Gläsersteller

CLASSIC

coaster for glasses
dessous de verre
portavasos
sottobicchiere

Ø Schale cm	dish Ø in.
9,5	3 ³ / ₄

Cromargan® versilbert
stainless 18/10 silverplated
06.2178.6040 19.2178.6440



Eiswasserkrug URBAN

water pitcher
carafe à l'eau
jarra agua
brocca per acqua

mit Eislippe /
with ice-trap

Cromargan® / stainless 18/10

Höhe cm	height in.	Inhalt Ltr.	cap. oz.
18,5	7 ¹ / ₄	1,5	50,7

06.3371.6041



Eiswasserkrug CLASSIC

water pitcher
carafe à l'eau
jarra agua
brocca per acqua

mit Eislippe /
with ice-trap

Höhe cm	height in.	Inhalt Ltr.	cap. oz.
19	7 ¹ / ₂	1,5	52,5

Cromargan®
stainless 18/10
06.1861.6040 versilbert
silverplated
19.1861.6440



Eiswasserkrug SCALA

water pitcher
carafe à l'eau
jarra agua
brocca per acqua

mit Eislippe /
with ice-trap

Höhe cm	height in.	Inhalt Ltr.	cap. oz.
23	9	1,9	67

Cromargan®
stainless 18/10
06.1866.6041 versilbert
silverplated
19.1866.6441



Eiswasserkrug

water pitcher
carafe à l'eau
jarra agua
brocca per acqua

mit Eislippe /
with ice-trap

Cromargan® / stainless 18/10

Höhe cm	height in.	Inhalt Ltr.	cap. oz.
22	8 ³ / ₄	1,5	52,5

06.1860.6040

**Eiswasserkrug
PURE**

water pitcher
carafe à l'eau
jarra agua
brocca per acqua

mit Eislippe /
with ice-trap

Cromargan®, teilmattiert /
stainless 18/10, partly satin finished

Höhe	height	Inhalt	cap.
cm	in.	Ltr.	oz.
20	8	1,9	66,5

06.1865.6040

Eiswasserkrug

water pitcher
pichet à eau froide double paroi
jarra agua
brocca termica a doppia parete

doppelwandig, mit Eislippe /
double wall, with ice-trap

Cromargan® / stainless 18/10

Höhe	height	Inhalt	cap.
cm	in.	Ltr.	oz.
23,5	9¼	1,5	50,7

55.0049.6040

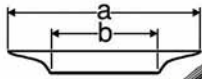

**Platzteller
RESIDENCE**

plate tray
assiette de présentation
bajoplato
piatto segnaposto

Cromargan® / stainless 18/10

Ø a	Ø a	Ø b	Ø b
cm	in.	cm	in.
33	13	19	7½

06.7473.6090*

* Rand geprägt / striked rim

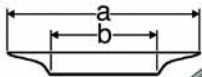

Platzteller

plate tray
assiette de présentation
bajoplato
piatto segnaposto

Ø a	Ø a	Ø b	Ø b	Cromargan®	versilbert
cm	in.	cm	in.	stainless 18/10	silverplated
32	12½	19	7½	06.7416.9990*	19.7416.6440*
33	13	21	8¼	06.7417.6040**	

* für Teller Ø 28 cm / for plates Ø 11 in.

** für Teller Ø 30 cm / for plates Ø 11¾ in.



**Teller cloche
CLASSIC**

plate cover
cloche pour assiette
campana con pomolo
copripiatto con pomolo

auflegend /
salient

Ø Fond	Ø inside	Cromargan®	versilbert
cm	in.	stainless 18/10	silverplated
25	9¾	06.7148.6040	19.7148.6440



**Teller cloche
NEUTRAL**

plate cover
cloche pour assiette
campana con pomolo
copripiatto con pomolo

auflegend /
salient

Cromargan® / stainless 18/10

Ø Fond	Ø inside
cm	in.
25	9¾

06.7113.6040



Teller cloche

plate cover
 cloche pour assiette
 campana
 copripiatto con pomolo

stapelbar /
 stackable

Cromargan® / stainless 18/10

Ø Fond cm	Ø inside in.
26	10 ¹ / ₄
27,1	10 ³ / ₄
28	11

06.7089.6040

06.7086.6040

06.7087.6040



**Sauciere
NEUTRAL**

gravy boat
sauceière
salsera
salsiere

auf Fuß /
footed

Cromargan® / stainless 18/10

Inhalt	cap.
Ltr.	oz.
0,15	5,3
0,3	10,5
0,5	17,5

06.6244.6040
06.6245.6040
06.6246.6040



**Sauciere
PURE**

gravy boat
sauceière
salsera
salsiere

auf Fuß, stapelbar /
footed, stackable

Cromargan® teil mattiert / stainless 18/10 partly satin finished

Inhalt	cap.
Ltr.	oz.
0,2	7
0,5	17,5

06.0473.6040
06.0474.6040



**Légumier
CLASSIC**

vegetable dish and cover
légumier et couvercle
legumbrera con tapa
legumiera con coperchio

Cromargan® / stainless 18/10

Inhalt	cap.	Ø	Ø	Unterteil	Deckel
Ltr.	oz.	cm	in.	base	cover
0,35	12,3	14	5 1/2	06.2701.6041	06.2701.6042
		14	5 1/2		
0,6	21	16	6 1/4	06.2702.6041	06.2702.6042
		16	6 1/4		
1,4	49	22	8 3/4	06.2704.6041	06.2704.6042
		22	8 3/4		

versilbert / silverplated

Inhalt	cap.	Ø	Ø	Unterteil	Deckel
Ltr.	oz.	cm	in.	base	cover
0,35	12,3	14	5 1/2	19.2701.6441	19.2701.6442
		14	5 1/2		
0,6	21	16	6 1/4	19.2702.6441	19.2702.6442
		16	6 1/4		
1,4	49	22	8 3/4	19.2704.6441	19.2704.6442
		22	8 3/4		



**Légumier
NEUTRAL**

vegetable dish and cover
légumier et couvercle
legumbrera con tapa
legumiera con coperchio

Cromargan® / stainless 18/10

Inhalt Ltr.	cap. oz.	Ø cm	Ø in.	Unterteil base	Deckel cover
0,35	12,3	14	5½	06.2786.6041	06.2786.6042
0,6	21	14	5½	06.2787.6041	06.2787.6042
		16	6¼	06.2788.6041	06.2788.6042
0,9	31,5	16	6¼	06.2788.6041	06.2788.6042
		18	7	06.2789.6041	06.2789.6042
1,4	49	18	7	06.2789.6041	06.2789.6042
		22	8¾	06.2789.6041	06.2789.6042
		22	8¾		06.2789.6042



**Suppenterrine
CLASSIC**

soup tureen
soupière
sopera
zuppiera

Cromargan® / stainless 18/10

Inhalt Ltr.	cap. oz.	Ø cm	Ø in.	Unterteil base	Deckel cover
0,9	31,5	16	6¼	06.7200.6041	06.7200.6042
		16	6¼		06.7200.6042
2,5	87,5	22	8¾	06.7201.6041	06.7201.6042
		22	8¾		06.7201.6042

versilbert / silverplated

Inhalt Ltr.	cap. oz.	Ø cm	Ø in.	Unterteil base	Deckel cover
0,9	31,5	16	6¼	19.7200.6441	19.7200.6442
		16	6¼		19.7200.6442
2,5	87,5	22	8¾	19.7201.6441	19.7201.6442
		22	8¾		19.7201.6442



**Suppenterrine
NEUTRAL**

soup tureen
soupière
sopera
zuppiera

Fuß, Deckel, Löffel-Ausschnitt im Deckel /
foot, cover, hole for spoon in cover

Cromargan® / stainless 18/10

Inhalt Ltr.	cap. oz.	Ø cm	Ø in.	Unterteil base	Deckel cover
2,5	87,5	22	8¾	06.7310.6041	06.7310.6042
		22	8¾		06.7310.6042

Servierpfanne / Paella Pfanne

pàella pan
 plat à pàella
 paellera
 padella per servizio

Cromargan® / stainless 18/10

Ø	Ø
cm	in.
36	14 ¹ / ₄

06.6881.6040

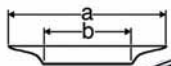

Bratenplatte, oval

meat platter, oval
 plat, ovale
 fuente, oval
 vassoio, ovale

Cromargan® / stainless 18/10

Größe a	size a	Größe b	size b	
cm	in.	cm	in.	
37 x 25,5	14 ¹ / ₂ x 10	29 x 17	11 ¹ / ₂ x 6 ³ / ₄	06.0603.6040
42 x 28,5	16 ¹ / ₂ x 11 ¹ / ₄	33 x 19,5	13 x 7 ³ / ₄	06.0604.6040
53 x 35	20 ³ / ₄ x 13 ³ / ₄	43 x 24,5	17 x 9 ³ / ₄	06.0606.6040



Universalteller

all purpose dish
 plat universel
 plato universal
 piatto multioso

Cromargan® / stainless 18/10

Höhe	height	Ø	Ø	
cm	in.	cm	in.	
2,5	1	10	4	06.0292.6040



Universalschale PURE

universal dish
 coupe universelle
 recipiente universal
 ciotola universale

stapelbar /
 stackable

Cromargan® teilmattiert / stainless 18/10 partly satin finished

Höhe	height	Ø Schale	dish Ø	
cm	in.	cm	in.	
5,5	2 ¹ / ₄	12	4 ³ / ₄	06.1799.6040



Universalschale

finger bowl
coupe universelle
recipiente universal
ciotola universale

Cromargan® / stainless 18/10

Inhalt	cap.	Ø Schale	dish Ø
Ltr.	oz.	cm	in.
0,2	7	12	4 ³ / ₄

06.1849.6040**Butterkühler
CLASSIC**

butter cooler
refraîchisseur à beurre
enfriador para mantequilla
rinfresca-burro

Höhe	height	Ø	Ø	Cromargan®	versilbert
cm	in.	cm	in.	stainless 18/10	silverplated
8	3 ¹ / ₄	5,5	2 ¹ / ₄	06.1090.6040	19.1090.6440

Ersatzteil / spare part:
Porzellanunterteil / porcelain base

60.3038.0690

**Butterkühler
CLASSIC**

butter cooler
refraîchisseur à beurre
enfriador para mantequilla
rinfresca-burro

mit Unterteller /
with underliner

Höhe	height	Ø	Ø	Cromargan®	versilbert
cm	in.	cm	in.	stainless 18/10	silverplated
6	2 ¹ / ₄	15,5	6	06.1087.6040	19.1087.6440

Ersatzteil / spare part:

Unterteil / base	06.1085.6041	19.1085.6441
Einsatzsieb / sieve	06.1085.6044	19.1085.6444
Cloche / cover	06.1087.6042	19.1087.6442
Unterteller / underliner	06.1087.6043	19.1087.6443





Butterkühler

NEUTRAL

butter cooler
refraîchisseur à beurre
enfriador para mantequilla
rinfresca-burro

mit Unterteller /
with underliner

Cromargan® / stainless 18/10

Höhe	height	Ø	Ø
cm	in.	cm	in.
6,5	2½	14,5	5¾

06.1089.6040

Ersatzteil / spare part:

Unterteil / base	06.1089.6041
Einsatzsieb / sieve	06.1089.6044
Unterteller / underliner	06.1089.6043
Cloche / cover	06.1089.6042



Butterkühler

CLASSIC

butter cooler
refraîchisseur à beurre
enfriador para mantequilla
rinfresca-burro

	Ø	Ø	Cromargan®	versilbert
	cm	in.	stainless 18/10	silverplated
Unterteil / base	12	4¾	06.3847.6041	19.3847.6441
Einsatz / sieve			06.1082.6044	19.1082.6444



Butterkühler

butter cooler
refraîchisseur à beurre
enfriador para mantequilla
rinfresca-burro

Cromargan® / stainless 18/10

	Inhalt	cap.	Ø Schale	dish Ø	
	Ltr.	oz.	cm	in.	
Universalschale / finger bowl	0,2	7	12	4¾	06.1849.6040
Einsatz / sieve					06.1082.6044



Happy Spoon Gestell

Happy Spoon stand
présentoir Happy Spoon
soporte Happy Spoon
porta Happy Spoon

für 8 Happy Spoons /
for 8 happy spoons

Cromargan® / stainless 18/10

Größe	size
cm	in.
13 x 11 x 26,25	5 x 4 ¹ / ₄ x 10 ¹ / ₄

06.8344.6040

Zubehör / accessory:

Happy Spoon S	12.8345.6040
Happy Spoon	12.8993.6040

Dessertgestell PURE EXCLUSIV

dessert stand
présentoir à gâteau
soporte plato postre
porta piattini per dessert

Mit 3 Einsätzen für wahlweise Gläser S, Tassen S (o. Abb.) oder
Sahnekännchen (o. Abb.) mit oder ohne Deckel von KAFFEEKULTUR.
Nicht spülmaschinengeeignet! /
With 3 inserts alternatively for glasses S, cups S (w/o pic.) or creamer
(w/o pic.) with or w/o lid of CoffeeCulture. Not dishwasher-safe!



Cromargan®, Holz dunkel gebeizt /
stainless 18/10, wood dark stained

Teelichtleuchter 3fl. klein / tealight candle stick, small

Größe	size
cm	in.
20,5 x 6,2 x 3,7	8 x 2 ¹ / ₂ x 1 ¹ / ₂

55.0039.6040

Glas S / glass S

Höhe	height	Inhalt	cap.
cm	in.	Ltr.	oz.
7,4	3	0,09	3,2

60.2506.9990

Dessertgestell PURE EXCLUSIV

dessert stand
présentoir à gâteau
soporte plato postre
porta piattini per dessert

Mit 3 Einsätzen für wahlweise Gläser S (o. Abb.), Tassen S (o. Abb.) oder Sahnekännchen mit oder ohne Deckel von KAFFEEKULTUR.

Nicht spülmaschinengeeignet! /

With 3 inserts alternatively for glasses S (w/o pic.), cups S (w/o pic.) or creamer with or w/o lid of CoffeeCulture. Not dishwasher-safe!



Cromargan®, Holz dunkel gebeizt /
stainless 18/10, wood dark stained

Teelichtleuchter 3fl. klein / tealight candle stick, small

Größe	size
cm	in.
20,5 x 6,2 x 3,7	8 x 2 ¹ / ₂ x 1 ¹ / ₂

55.0039.6040

Sahnekännchen / creamer

Höhe	height	Inhalt	cap.
cm	in.	Ltr.	oz.
7	2 ³ / ₄	0,08	2,7

55.0033.9990

Deckel mit Ausschnitt / lid with cut-out

55.0031.6040

Espresso-/Mokkalöffel / demi-tasse spoon

54.9901.6040

Menage PURE EXCLUSIV

menage
menagère, à tapenades
set 3 recipientes
ménage per tapenade

für Tapenade, Fleur de Sel oder Saucen und Dips /
for tapenade, fleur de sel or dips

Cromargan®, Holz dunkel gebeizt /
stainless 18/10, wood dark stained



Teelichtleuchter 3fl. klein / tealight candle stick, small

Größe	size
cm	in.
20,5 x 6,2 x 3,7	8 x 2 ¹ / ₂ x 1 ¹ / ₂

55.0039.6040

Porzellanschälchen (6er) / porcelain bowl (6 pcs.)

Höhe	height	Ø	Ø
cm	in.	cm	in.
4	1 ¹ / ₂	5	2

55.0093.9990

Gewürzlöffel / spicy spoon

Länge	length
cm	in.
7	2 ³ / ₄

54.9184.6040



Dessertgestell

dessert stand
présentoir à gâteau
soporte plato postre
porta piattini per dessert

ohne Gläser /
w/o glasses

Cromargan® / stainless 18/10

Größe	size
cm	in.
40,6 x 7 x 4,9	16 x 2 ³ / ₄ x 2

06.8230.6040

Zubehör / accessory:
Glas S / glass S

60.2506.9990



Dessertgestell

dessert stand
présentoir à gâteau
soporte platos postre
porta piattini per dessert

passend für Teller bis Ø 16 cm (ohne Teller) /
fitting for plates Ø 6¹/₄ in. (without plates)

Cromargan® / stainless 18/10

Höhe	height	Ø	Ø	Ø Ring	Ø ring
cm	in.	cm	in.	cm	in.
25,5	10	18,5	7 ¹ / ₄	10,5	4 ¹ / ₄

06.4397.6040



Serviergestell

serving stand
présentoir à assiette
soporte platos
portapiatti

passend für Teller Ø 26 cm (ohne Teller) /
fitting for plates Ø 10¹/₄ in. (without plates)

Cromargan® / stainless 18/10

Höhe	height	Ø	Ø	Ø Ring	Ø ring
cm	in.	cm	in.	cm	in.
40	15 ³ / ₄	28,5	11 ¹ / ₄	18,6	7 ¹ / ₄

06.4395.6040



Austernplatte

oyster platter
plat à fruits de mer
fuente para mariscos
piatto per ostriche

Cromargan® / stainless 18/10

	Ø	Ø	
	cm	in.	
Servierpfanne / Paella Pfanne / pàella pan	36	14 ¹ / ₄	06.6881.6040
Einsatz / insert			06.6934.6044



Austerngestell

oyster rack
support plateau fruits de mer
soporte fuente
supporto per piatto ostriche

Cromargan® / stainless 18/10

Höhe	height	Ø	Ø	
cm	in.	cm	in.	
18	7	27,5/34	10 ³ / ₄ /13 ¹ / ₂	06.6933.6010



Kaviarkühler CLASSIC

caviar cooler
refraîchisseur à caviar
enfriador caviar
rinfresca-caviale

	Ø	Ø	Cromargan®	versilbert
	cm	in.	stainless 18/10	silverplated
Unterteil / base	12	4 ³ / ₄	06.3847.6041	19.3847.6441
Einsatz / insert			06.3851.6044	19.3851.6444
Glaseinsatz / glass insert				19.9999.8617



Kaviar-Bowl CLASSIC

caviar cooler
refraîchisseur à caviar
enfriador caviar
rinfresca-caviale

inklusive Einsatz-Kreuz und Glas-Einsatz /
including glass holder and glass insert

versilbert / silverplated

Höhe	height	Ø	Ø	
cm	in.	cm	in.	
15,5	6	26	10 ¹ / ₄	19.3848.6440

Ersatzteil / spare part:				
Einsatz-Kreuz / glass holder				06.3850.6043
Glaseinsatz / glass insert				19.9999.8622
Unterteil / bowl				19.3848.6441



Chillcup CLASSIC

chillcup
chillcup
copa cóctel mariscos
chillcup

mit Ring und Metalleinsatz /
with ring and metal insert

Inhalt	cap.	Ø	Ø
Ltr.	oz.	cm	in.
0,12	4,2	12	4 ³ / ₄

Unterteil / base
Metalleinsatz / metal insert
Ring / ring

Cromargan® versilbert
stainless 18/10 silverplated
06.3847.6041 19.3847.6441
06.3853.6044 19.3853.6444
06.3853.6045 19.3853.6445



Chillcup CLASSIC

chillcup
chillcup
copa cóctel mariscos
chillcup

mit Ring und Glaseinsatz /
with ring and glass insert

Inhalt	cap.	Ø	Ø
Ltr.	oz.	cm	in.
0,12	4,2	12	4 ³ / ₄

Unterteil / base
Ring / ring
Glasschale / glass dish

Cromargan® versilbert
stainless 18/10 silverplated
06.3847.6041 19.3847.6441
06.3853.6045 19.3853.6445
19.9999.8616



Eisschale

ice cream bowl
coupe à glace
copa helado
coppa gelato

Cromargan® / stainless 18/10

Höhe	height	Inhalt	cap.	Ø	Ø
cm	in.	Ltr.	oz.	cm	in.
4,5	1 ³ / ₄	0,1	3,38	10,5	4 ¹ / ₄

55.0093.6040



**Mokkaétagère
CLASSIC**

pastry stand
porte petits fours
portapastas
alzata portadolci

2 Ebenen /
2 levels

versilbert / silverplated

Höhe cm	height in.	Ø Schale cm	Ø bowl in.	
21,5	8½	10,7 / 15,5	4¼ / 6	19.6907.6440
27,5	10¾	15,5 / 23	6 / 9	19.6908.6440



**Mokkaétagère
URBAN**

pastry stand
porte petits fours
portapastas
alzata porta dolci

Cromargan® / stainless 18/10

Höhe cm	height in.	Ø cm	Ø in.	
13,3	5¼	20	7¾	55.0066.6040



**Mokkaétagère, 3-teilig
PURE**

pastry stand, 3 parts
porte petits fours, en 3 parties
portapastas, de 3 pisos
alzata portadolci, 3 piani

Cromargan® / stainless 18/10

Höhe cm	height in.	Ø Schale cm	Ø bowl in.	
22,5	8¾	9 / 14 / 20	3½ / 5½ / 8	06.6903.6040



**Mokkaétagère, 2 tlg. Pure
PURE**

pastry stand, 2 parts
porte petits fours, en 2 parties
portapastas, de 2 pisos
alzata portadolci, 2 piani

Cromargan® / stainless 18/10

Höhe cm	height in.	Ø cm	Ø in.	Ø Schale cm	Ø bowl in.	
14,5	5¾	20	7¾	14 / 20	5½ / 8	06.8254.6040



Petits Fours-Ständer CLASSIC

petits-fours-stand
porte petits fours
portapastas
alzata porta dolci

Höhe	height	Ø	Ø	Cromargan®	versilbert
cm	in.	cm	in.	stainless 18/10	silverplated
13	5	15,5	6	06.4379.6040	19.4379.6440



Petits Fours-Ständer URBAN

petits-fours-stand
porte petits fours
portapastas
alzata porta dolci

Cromargan® / stainless 18/10

Höhe	height	Ø	Ø	
cm	in.	cm	in.	
8,7	3 1/2	15	6	55.0067.6040



Petits Fours-Ständer PURE EXCLUSIV

petits-fours-stand
porte petits fours
portapastas
alzata porta dolci

Metall-Oberteil entnehmbar zum Spülen. Holzfuß nicht
spülmaschinenfest! /
metal part removable for cleaning. Wooden foot not dishwasher-safe!

Cromargan®, Holz dunkel gebeizt /
stainless 18/10, wood dark stained

Höhe	height	Ø	Ø	
cm	in.	cm	in.	
14	5 1/2	15	6	55.0073.6040



Petits Fours-Ständer PURE

petits-fours-stand
porte petits fours
portapastas
alzata porta dolci

Cromargan® teilmattiert / stainless 18/10 partly satin finished

Höhe	height	Ø	Ø	
cm	in.	cm	in.	
10,4	4	15	6	06.0475.6040



Petits Fours-Ständer

NEUTRAL

petits-fours-stand
 porte petits fours
 portapastas
 alzata porta dolci

Cromargan® / stainless 18/10

Höhe	height	Ø	Ø
cm	in.	cm	in.
9	3 1/2	15,5	6

06.4380.6040



Marmeladegestell

jam stand
 support pour confiture
 soporte para mermelada
 supporto per confettura

mit 5 Ablageflächen mit max. Durchm. 4,9 cm, Vase mittig /
 with 5 levels with dia. max. 2 in., flower vase in the middle

Cromargan® / stainless 18/10

Höhe	height
cm	in.
20	7 3/4

06.8231.6040



Porzellanschale, 3-geteilt

PURE

porcelain bowl 3-section
 coupe en porcelaine 3 parties
 cuenco de porcelana 3 divisiones
 vassoietto tripartito portazzucchero

mit 2 Unterteilungen für Tee, Zucker oder Antipasti /
 with 2 partitions for tea, sugar or Antipasti

Porzellan weiß / porcelain white

Größe	size
cm	in.
21 x 8,7 x 3,25	8 1/4 x 3 1/2 x 1 1/4

60.3538.9990

Zubehör / accessory:

Tablett, oval / serving tray, oval

06.7551.6040

Größe	size
cm	in.
24,5 x 12	9 1/2 x 4 3/4

**Toastständer****PURE**

toast rack
support pour pain grillé
portatostadas
porta-toast

passend in Tablett 06.7551.6040 /
fitting in serving tray 06.7551.6040

Cromargan® / stainless 18/10

Größe	size
cm	in.
20 x 8 x 6,5	8 x 3 ¹ / ₄ x 2 ¹ / ₂

06.4280.6040**Tablett, oval****PURE**

serving tray, oval
plateau de service, ovale
bandeja, oval
vassoio, ovale

passend für Toastständer 06.4280.6040 und Porzellanschale 3geteilt
60.3538.9990 /
suitable for toast rack 06.4280.6040 and for porcelain bowl 3pcs.
60.3538.9990

stapelbar /
stackable

Cromargan® / stainless 18/10

Größe	size
cm	in.
24,5 x 12	9 ¹ / ₂ x 4 ³ / ₄

06.7551.6040

**Eierbecher / Teelicht / Vase****KaffeeKultur**

egg cup / tealight / vase

coquetier / bougie à chauffe-plat, porcelaine

huevera / candela, porcelana

portauovo / candela scaldavivande, porcellana

Porzellangefäß als Eierbecher, Vase oder Teelicht einsetzbar /

porcelain insert, to use as egg cup, flower vase or tealight holder

Cromargan® / stainless 18/10

Sahnekännchen / creamer

Höhe cm	height in.	Inhalt Ltr.	cap. oz.	
7	2 ³ / ₄	0,08	2,7	55.0033.9990

Eierbecher- / Teelicht-Aufsatz /
egg cup / tealight insert**55.0032.6040**

Ring S / ring S

06.2502.6040

Espresso-/Mokkalöffel / demi-tasse spoon

54.9901.6040**Eierbecher-Set**

egg cup set

set de coquetier

set de huevera

set portauovo

stapelbar /

stackable

Cromargan® / stainless 18/10

Ø cm	Ø in.	Stück pcs.	
8,5	3 ¹ / ₃	6	06.1640.6040

**Eierlöffel**

egg spoon

cuiller à oeuf

cuchara huevos

cucchiaio per uovo

Cromargan® / stainless 18/10

Länge cm	length in.	
13	5	12.9008.6040



**Tischrestebehälter****PURE**

silent waiter
boîte de table
recipiente desperdicios
porta rifiuti per tavolo

Deckel zum Abnehmen, auch als Kühler für kleine Flaschen einsetzbar /
detachable lid, can also be used to cool small bottles

stapelbar /
stackable

Cromargan® teilmattiert / stainless 18/10 partly satin finished

Höhe	height	Ø	Ø	
cm	in.	cm	in.	
15	6	14	5½	06.1758.6040

**Tischrestebehälter**

silent waiter
boîte de table
recipiente desperdicios
porta rifiuti per tavolo

stapelbar, stoßfest, spülmaschinengeeignet /
stackable, impact-resistant, dishwasher suitable

hochwertiger Kunststoff „Luran“, Dekor Shadow /
high quality plastic, design Shadow

Höhe	height	Ø unten	Ø lower	Ø oben	Ø upper	
cm	in.	cm	in.	cm	in.	
16	6¼	10	4	14	5½	19.9999.2201

**Krümelsammler**

table crumbler
ramasse-brosse
recogemigas
raccoglibriciole

Cromargan® / stainless 18/10

Länge	length	
cm	in.	
15	6	06.7707.6000

**Zahnstocherbehälter****CLASSIC**

toothpick-holder
porte-cure-dents
palillero
porta stuzzicadenti

Höhe	height	rostfrei	versilbert
cm	in.	stainless steel	silverplated
6	2¼	06.8406.1680	19.8406.1440

Zahnstocherbehälter

PURE

toothpick-holder
 porte-cure-dents
 palillero
 porta stuzzicadenti

Cromargan®, teilmattiert /
 stainless 18/10, partly satin finished

Höhe	height
cm	in.
7	2 ³ / ₄

06.8413.6040



Zahnstocher- und Süßstoffbehälter

PURE

toothpick- and sweetener box-holder
 porte-cure-dents et récipient pour sucrètes
 palillero y dispensador de edulcorante
 porta stuzzicadenti e contenitore per dolcificante

zum Einhängen in alle WMF PURE-Gestelle mit Bügelgriff.

Laser-Gravur der Tischnummer nach Wunsch - Preis auf Anfrage /
 fitting in all racks of WMF PURE sets. Engraving of the table No. on
 request - please ask for respective costs

Cromargan® / stainless 18/10

Höhe	height
cm	in.
4	1 ¹ / ₂

06.1905.6044





Früchtekorb

fruit basket
panier à fruits
frutero
fruttiera

passend in Etagère 06.3010.6040, 06.3011.6040, 06.2441.6040
combiNation buffet nur in Verbindung mit Kühlbehälter 06.3014.6045
(bitte separat bestellen) /
fitting together with cooler 06.3014.6045 (please order separately) in
etagere 06.3010.6040, 06.3011.6040, 06.2441.6040 combiNation buffet

Cromargan® / stainless 18/10

Höhe	height	Ø	Ø
cm	in.	cm	in.
22,5	8 ³ / ₄	26	10 ¹ / ₄

06.6521.6040



**Brotkorb, rund
OLE PALSBY**

bread-basket, round
panier à pain, rond
cesta del pan, redonda
cestino per il pane, rotondo

Cromargan® / stainless 18/10

Ø	Ø
cm	in.
18	7 ¹ / ₂
26	10 ¹ / ₄

06.6575.6040

06.6514.6040



**Brotkorb
PURE**

bowl for bread
panier à pain
panera
portapane

stapelbar /
stackable

Cromargan® teilmattiert / stainless 18/10 partly satin finished

Größe	size
cm	in.
25 x 14 x 5	9 ³ / ₄ x 5 ¹ / ₂ x 2

06.6535.6040



Brotkorb

bread-basket
panier à pain
cesta del pan
cestino per il pane

oval /
oval

versilbert / silverplated

Größe	size
cm	in.
22,3 x 16,3 x 6	8 ³ / ₄ x 6 ¹ / ₂ x 2 ¹ / ₄
27 x 19 x 6,5	10 ³ / ₄ x 7 ¹ / ₂ x 2 ¹ / ₂

19.6319.7030

19.6329.6440

Brottschale

bowl for bread
panier à pain
panera
portapane

Größe	size
cm	in.
28 x 17	11 x 6 ³ / ₄

Cromargan®	versilbert
stainless 18/10	silverplated
06.6380.6040	19.6380.6440



Brottschale

bowl for bread
panier à pain
panera
portapane

oval, Durchbruchdekor /
oval, stencil pattern

Cromargan® / stainless 18/10

Größe	size
cm	in.
20 x 15	8 x 6

06.6571.6040



Universalschale

PURE

universal dish
coupe universelle
recipiente universal
ciotola universale

stapelbar /
stackable

Cromargan® teilmattiert / stainless 18/10 partly satin finished

Höhe	height	Ø Schale	dish Ø
cm	in.	cm	in.
5,5	2 ¹ / ₄	12	4 ³ / ₄

06.1799.6040



Universalschale

finger bowl
coupe universelle
recipiente universal
ciotola universale

Cromargan® / stainless 18/10

Inhalt	cap.	Ø Schale	dish Ø
Ltr.	oz.	cm	in.
0,2	7	12	4 ³ / ₄

06.1849.6040





**Cocktail- und Dessertschale
CLASSIC**

cocktail and dessert dish
coupe à cocktail et dessert
copa cóctel y postre
coppa per cocktail e frutta

Höhe	height	Ø	Ø	Cromargan®	versilbert
cm	in.	cm	in.	stainless 18/10	silverplated
13,5	5 1/4	11,4	4 1/2	06.1878.6040	19.1878.6440



Eisschale

ice cream cup
coupe à glace
recipiente universal
coppa gelato

Cromargan® / stainless 18/10

Höhe	height	Inhalt	cap.	Ø	Ø	
cm	in.	Ltr.	oz.	cm	in.	
4,5	1 3/4	0,11	2,9	9,5	3 3/4	06.1830.6040



**Obstschale
BISTRO**

fruit stand
coupe à fruits
frutero
alzata per frutta

Cromargan®, Glas / stainless 18/10, glass

Höhe	height	Ø Schale	Ø bowl	
cm	in.	cm	in.	
16	6 1/4	38	15	06.6895.6040

Ersatzteil / spare part:

Glasschale mittel / glass plate medium	19.9999.8644
--	--------------



**Obstschale
CLASSIC**

fruit bowl
coupe à fruits
frutero
alzata per frutta

Höhe	height	Ø	Ø	Cromargan®	versilbert
cm	in.	cm	in.	stainless 18/10	silverplated
14	5 1/2	23	9	06.6483.6040	19.6483.6440



Früchtekorb

fruit basket
corbeille de fruits
cesta de frutas
cesto di frutta

Cromargan® / stainless 18/10

Größe	size
cm	in.
36 x 24 x 5	14 ¹ / ₄ x 9 ¹ / ₂ x 2

06.8237.6040



Obtschale

fruit bowl
coupe à fruits
frutero
alzata per frutta

oval /
oval

Cromargan® / stainless 18/10

Größe	size
cm	in.
22 x 27 x 13,5	8 ³ / ₄ x 10 ³ / ₄ x 5 ¹ / ₄

06.8238.6040



Obtschale

fruit bowl
coupe à fruits
frutero
alzata per frutta

Cromargan® / stainless 18/10

Größe	size
cm	in.
22,5 x 22,5 x 7,2	8 ³ / ₄ x 8 ³ / ₄ x 2 ³ / ₄
34,5 x 35 x 11	13 ¹ / ₂ x 13 ³ / ₄ x 4 ¹ / ₄

06.8236.6040

06.8235.6040



**Leuchter, 3-flammig
URBAN**

candelabra, 3-branched
chandelier, 3 branches
candelabro, 3 brazos
candelieri, 3 fiamme

Cromargan® / stainless 18/10

Länge cm	length in.	Höhe cm	height in.
23,8	9 ¹ / ₄	22,5	8 ³ / ₄

55.0069.6040

Zubehör / accessory:

Glasmanschette 20 Stück / drip-ring 20 pieces

60.3093.9920

Kerzen Packung 50 Stück / candles set of 50 pieces

60.3023.1950



**Leuchter, 3-armig
PURE**

candelabra, 3-branched
chandelier, 3 branches
candelabro, 3 brazos
candelieri, 3 fiamme

Cromargan®, teilmattiert /
stainless 18/10, partly satin finished

Höhe cm	height in.
36	14 ¹ / ₄

06.4753.6040

Zubehör / accessory:

Glasmanschette 20 Stück / drip-ring 20 pieces

60.3093.9920

Kerzen Packung 50 Stück / candles set of 50 pieces

60.3023.1950



**Leuchter, 5-armig
PURE**

candelabra, 5-branched
chandelier, 5 branches
candelabro, 5 brazos
candelieri, 5 fiamme

Cromargan®, teilmattiert /
stainless 18/10, partly satin finished

Höhe cm	height in.
36	14 ¹ / ₄

06.4754.6040

Zubehör / accessory:

Glasmanschette 20 Stück / drip-ring 20 pieces

60.3093.9920

Kerzen Packung 50 Stück / candles set of 50 pieces

60.3023.1950



**Leuchter
CLASSIC**

candle stick
chandelier
candelero
candeliere

versilbert / silverplated

Höhe	height
cm	in.
12	4 ³ / ₄

19.4990.6440



**Leuchter
URBAN**

candle stick
chandelier
candelero
candeliere

Cromargan® / stainless 18/10

Länge	length	Höhe	height
cm	in.	cm	in.
6,4	2 ¹ / ₂	21	8 ¹ / ₄

55.0060.6040



**Leuchter
NEUTRAL**

candle stick
chandelier
candelero
candeliere

Cromargan® / stainless 18/10

Höhe	height
cm	in.
10,5	4 ¹ / ₄

06.4998.6040



**Leuchter
NEUTRAL**

candle stick
chandelier
candelero
candeliere

Cromargan® / stainless 18/10

Höhe	height
cm	in.
18	7

06.4999.6040



**Leuchter
PURE EXCLUSIV**

candle stick
chandelier
candelero
candeliere

Cromargan®, Holz dunkel gebeizt /
stainless 18/10, wood dark stained

Höhe	height	Ø	Ø	
cm	in.	cm	in.	
20,4	8	9	3 1/2	55.0018.6040
30,4	12	9	3 1/2	55.0017.6040



**Leuchter
PURE**

candle stick
chandelier
candelero
candeliere

Cromargan®, teilmattiert /
stainless 18/10, partly satin finished

Höhe	height	
cm	in.	
5	2	06.4750.6040
10,5	4 1/4	06.4751.6040



**Windlicht
CLASSIC**

table lamp with glass
chandelier avec verrine
linternas con cristal
lampa da tavola alta con paralume

versilbert / silverplated

Höhe	height	
cm	in.	
23,5	9 1/4	19.4994.6440

Ersatzteil / spare part:
Ersatzglas / spare glass 19.9999.8638



**Windlicht
PURE**

table lamp with glass
chandelier avec verrine
linternas con cristal
lampa da tavola alta con paralume

Cromargan®, teilmattiert, Glas /
stainless 18/10, partly satin finished, glass

Höhe	height	
cm	in.	
21	8 1/4	06.8202.6040

Ersatzteil / spare part:
Ersatzglas / spare glass 60.3051.9990



**Windlicht, matt
PURE**

table lamp with glass, satin
chandelier avec verrine, mat
linternas con cristal, mate
lampa da tavola alta con paralume, di vetro satino

Cromargan®, teilmattiert, Glas /
stainless 18/10, partly satin finished, glass

Höhe	height
cm	in.
21	8 ¹ / ₄

06.8208.6040

Ersatzteil / spare part:
Ersatzglas / spare glass

60.3052.9990



**Windlicht
URBAN**

table lamp
chandelier avec verrine
linternas con cristal
lampa da tavola alta con paralume

Cromargan®, Glas / stainless 18/10, glass

Höhe	height	Ø	Ø
cm	in.	cm	in.
13,5	5 ¹ / ₄	8	3 ¹ / ₄

55.0070.6040

Ersatzteil / spare part:
Ersatzglas zu Windlicht / spare glass for table lamp

55.0070.9990



**Windlicht, groß
PURE EXCLUSIV**

table lamp, large
chandelier avec verrine, grand
linternas con cristal, alta
lampa da tavola alta con paralume, grande

ohne Kerzen. Für große Teelichte. Nicht spülmaschinengeeignet! /
w/o candles. For big tealights. Not dishwasher-safe!

Cromargan®, Holz dunkel gebeizt, Glas satiniert /
stainless 18/10, wood dark stained, glass satin finished

Größe	size	Ø	Ø
cm	in.	cm	in.
8 x 8 x 22,3	3 ¹ / ₄ x 3 ¹ / ₄ x 8 ³ / ₄	13	5

55.0040.6040

Ersatzteil / spare part:
Ersatzglas zu Windlicht groß /
spare glass for table lamp large

55.0040.6042



**Windlicht, klein
PURE EXCLUSIV**

table lamp, small
chandelier avec verrine, petit
linterna con cristal, pequeno
lampa da tavola alta c. paralum, picc.

ohne Kerzen. Für Teelichte. Nicht spülmaschinengeeignet! /
w/o candles. For tealights. Not dishwasher-safe!

Cromargan®, Holz dunkel gebeizt, Glas satiniert /
stainless 18/10, wood dark stained, glass satin finished

Größe	size	Ø	Ø	
cm	in.	cm	in.	
6,3 x 6,3 x 19,3	2 1/2 x 2 1/2 x 7 1/2	9,5	3 3/4	55.0075.6040

Ersatzteil / spare part:

Ersatzglas zu Windlicht / spare glass for table lamp	55.0075.6042
--	---------------------



**Teelichtleuchter 3fl. klein
PURE EXCLUSIV**

tealight candle stick, small
chandelier bougie à chauffe-plat
candelero lamparilla, peq.
candeliere lumino, picc

mit 3 Einsätzen für Teelichte, Stab- oder Stumpenkerzen.
Nicht spülmaschinengeeignet! /
with 3 inserts for tealights and other kinds of candles.
Not dishwasher-safe!

Cromargan®, Holz dunkel gebeizt /
stainless 18/10, wood dark stained

Größe	size			
cm	in.			
20,5 x 6,2 x 3,7	8 x 2 1/2 x 1 1/2			55.0039.6040



**Eierbecher / Teelicht, Glas
KaffeeKultur**

egg cup / tealight, glass
coquetier / bougie à chauffe-plat, verre
huevera / candela, cristal
portauovo / candela scaldavivande, vetro

Glasgefäß als Eierbecher oder Teelicht einsetzbar /
glass insert, to use as egg cup oder tealight

Cromargan®, Glas / stainless 18/10, glass

	Höhe	height	Inhalt	cap.	
	cm	in.	Ltr.	oz.	
Glas S / glass S	7,4	3	0,09	3,2	60.2506.9990
Ring S / ring S					06.2502.6040
Eierbecher- / Teelicht-Aufsatz / egg cup / tealight insert					55.0032.6040



**Eierbecher / Teelicht / Vase
KaffeeKultur**

egg cup / tealight / vase
coquetier / bougie à chauffe-plat, porcelaine
huevera / candela, porcelana
portauovo / candela scaldavivande, porcellana

Porzellangefäß als Eierbecher, Vase oder Teelicht einsetzbar /
porcelain insert, to use as egg cup, flower vase or tealight holder

Cromargan® / stainless 18/10

Sahnekännchen / creamer

Höhe cm	height in.	Inhalt Ltr.	cap. oz.	
7	2 ³ / ₄	0,08	2,7	55.0033.9990

Eierbecher- / Teelicht-Aufsatz /
egg cup / tealight insert

55.0032.6040

Ring S / ring S

06.2502.6040

Espresso-/Mokkalöffel / demi-tasse spoon

54.9901.6040



**Blumenvase
CLASSIC**

flower vase
vase à fleurs
florero
vaso da fiori

versilbert / silverplated

Höhe	height
cm	in.
16,5	6 ¹ / ₂

19.7962.1440



**Blumenvase
CLASSIC**

flower vase
vase à fleurs
florero
vaso da fiori

Cromargan® / stainless 18/10

Höhe	height
cm	in.
16	6 ¹ / ₄

06.7959.6040



**Blumenvase
URBAN**

flower vase
vase à fleurs
florero
vaso da fiori

Cromargan® / stainless 18/10

Höhe	height	Ø	Ø
cm	in.	cm	in.
17,5	7	7	2 ³ / ₄

55.0061.6040



**Blumenvase
NEUTRAL**

flower vase
vase à fleurs
florero
vaso da fiori

Cromargan® / stainless 18/10

Höhe	height
cm	in.
17	6 ³ / ₄

06.7937.6040



Blumenvase

PURE

flower vase
vase à fleurs
florero
vaso da fiori

Cromargan®, teilmattiert /
stainless 18/10, partly satin finished

Höhe	height
cm	in.
20	8

06.7955.6040



Blumenvase

flower vase
vase à fleurs
florero
vaso da fiori

Cromargan® / stainless 18/10

Höhe	height	Ø	Ø
cm	in.	cm	in.
30	11¾	10	4

06.8240.6040



Eierbecher / Teelicht / Vase

KaffeeKultur

egg cup / tealight / vase
coquetier / bougie à chauffe-plat, porcelaine
huevera / candela, porcelana
portauovo / candela scaldavivande, porcellana

Porzellangefäß als Eierbecher, Vase oder Teelicht einsetzbar /
porcelain insert, to use as egg cup, flower vase or tealight holder

Cromargan® / stainless 18/10

Sahnekännchen / creamer

Höhe	height	Inhalt	cap.
cm	in.	Ltr.	oz.
7	2¾	0,08	2,7

55.0033.9990

Eierbecher- / Teelicht-Aufsatz /
egg cup / tealight insert

55.0032.6040

Ring S / ring S

06.2502.6040

Espresso-/Mokkalöffel / demi-tasse spoon

54.9901.6040



**Blumenvase, klein
PURE EXCLUSIV**

flower vase, small
vase à fleurs, petit
florero, pequeno
vaso da fiori, piccolo

für einzelne Blüten. Nicht spülmaschinengeeignet! /
for single flowers. Not dishwasher-safe!

Cromargan®, Holz dunkel gebeizt /
stainless 18/10, wood dark stained

Größe	size	Ø	Ø
cm	in.	cm	in.
4,5 x 4,5 x 16	1 ³ / ₄ x 1 ³ / ₄ x 6 ¹ / ₄	2,8	1

55.0041.6040



**Blumenvase, groß
PURE EXCLUSIV**

flower vase, large
vase à fleurs, grande
florero, grande
vaso da fiori, grande

nicht spülmaschinengeeignet! /
not dishwasher-safe!

Cromargan®, Holz dunkel gebeizt /
stainless 18/10, wood dark stained

Größe	size	Ø	Ø
cm	in.	cm	in.
8 x 8 x 23,5	3 ¹ / ₄ x 3 ¹ / ₄ x 9 ¹ / ₄	5,2	2

55.0042.6040



Tischnummernständer CLASSIC

table number stand
porte numéro de table
porta número de mesa
targhetta ad appoggio per numero tavolo

individuelle Gravur nach Wunsch - Preis auf Anfrage /
individual engraving on request - please ask for respective costs

Höhe	height	Cromargan®	versilbert
cm	in.	stainless 18/10	silverplated
54	21 ¹ / ₄	06.7819.6040	19.7819.6440

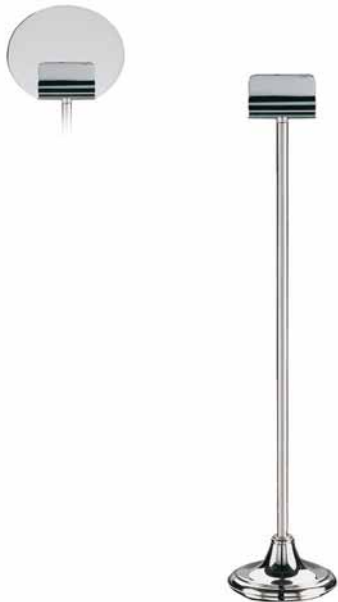

Tischnummernständer, mit Clip CLASSIC

table number stand, with clip
porte numéro de table, avec clip
porta número de mesa, con clip
segnatavola, con clip

Tischnummer separat zum Einstecken. /
Table No. to be put in separately.

Cromargan® / stainless 18/10

Höhe	height	Ø	Ø	
cm	in.	cm	in.	
45,4	17 ³ / ₄	9,7	3 ³ / ₄	06.8250.6040

Zubehör / accessory:

Tischnummer / table number 06.8252.6040

Plastik-Tischnummer, "Non Smoking" /
plastic table number, "Non Smoking" 19.9999.2514

Plastik-Tischnummer / plastic table number 19.9999.2513



Tischnummer

table number
numéro de table
número de mesa
numero tavolo

passend zu Tischnummernständer 06.8250.6040, 06.7812.6040 und
Speisekartenhalter 06.7813.6040. Individuelle Gravur nach Wunsch -
Preis auf Anfrage /
fitting for table number stand 06.8250.6040, 06.7812.6040 and menu
stand 06.7813.6040. Individual engraving on request - please ask for
respective costs

Cromargan® / stainless 18/10

Ø	Ø	
cm	in.	
13,5	5 ¹ / ₄	06.8252.6040



Tischnummernständer

PURE

table number stand
 porte numéro de table
 porta número de mesa (sin número)
 segnatavola

Cromargan®, teilmattiert /
 stainless 18/10, partly satin finished

Höhe	height
cm	in.
30,5	12

06.7812.6040

Zubehör / accessory:

Plastik-Tischnummer / plastic table number

19.9999.2513

Plastik-Tischnummer, "Non Smoking" /

plastic table number, "Non Smoking"

19.9999.2514

Tischnummer / table number

06.8252.6040



Plastik-Tischnummer

plastic table number
 numéro de table en plastique
 número de mesa plástico
 numero tavolo in plastica

passend in Tischnummernständer 06.7812.6040, 06.8250.6040 und
 Speisekartenhalter 06.7813.6040 PURE /
 fitting in table number stand 06.7812.6040, 06.8250.6040 and menu
 stand 06.7813.6040 PURE

Größe	size
cm	in.
10 x 10	4 x 4

19.9999.2513



Plastik-Tischnummer, "Non Smoking"

plastic table number, "Non Smoking"
 numéro de table en plastique „Non Smoking“
 número de mesa plástico „Non Smoking“
 numero tavolo in plastica

Kunststoff weiß mit Symbol "Non Smoking". Passend in
 Tischnummernständer 06.7812.6040, 06.8250.6040 und
 Speisekartenhalter 06.7813.6040 PURE. /
 plastic white with lable "Non Smoking". Fitting in table number stand
 06.7812.6040, 06.8250.6040 and menu stand 06.7813.6040 PURE.

Größe	size
cm	in.
10 x 10	4 x 4

19.9999.2514



Tischnummernständer

table number stand
 porte numéro de table
 porta número de mesa (sin grabación)
 targhetta ad appoggio per numero tavolo

Cromargan® / stainless 18/10

Höhe	height
cm	in.
28	11

06.7719.1680



Tischnummern-Aufsteller

table number
 numéro de table
 número de mesa
 targhetta ad appoggio per numero tavolo

passend zu Tischnummernständer 06.7719.1680, Laser-Gravur nach Wunsch - Preis auf Anfrage /
 fitting for table number stand 06.7719.1680, engraving on request - please ask for respective costs

Länge	length	Höhe	height	Cromargan®	versilbert
cm	in.	cm	in.	stainless 18/10	silverplated
8,3	3 1/4	3,6	1 1/2	06.7701.6040	19.7701.6440



Kartenhalter PURE EXCLUSIV

card holder
 porte-carte
 portatarjetas
 portacarta

für Tisch- und Visitenkarten /
 for menu and name cards

Cromargan®, Holz dunkel gebeizt /
 stainless 18/10, wood dark stained

Größe	size
cm	in.
4,5 x 4,5 x 6,5	18 3/4 x 18 3/4 x 2 1/2

55.0080.6040



Speisekartenhalter

PURE

menu stand
 porte menu
 porta menus
 portamenu

Cromargan®, teilmattiert /
 stainless 18/10, partly satin finished

Höhe	height
cm	in.
7,5	3

06.7813.6040

Zubehör / accessory:

Plastik-Tischnummer / plastic table number

19.9999.2513

Plastik-Tischnummer, "Non Smoking" /

19.9999.2514

plastic table number, "Non Smoking"

Tischnummer / table number

06.8252.6040



Kartenhalter

PURE

card holder
 porte-carte
 portatarjetas
 portacarta

zum Einhängen in alle WMF PURE-Gestelle mit Bügelgriff (außer
 06.5170.6040) /

fitting in all racks of WMF PURE sets (except 06.5170.6040)

Cromargan® / stainless 18/10

Größe	size
cm	in.
7,5 x 0,5 x 4,5	3 x 1/4 x 1 3/4

06.3803.6044



Zahnstocher- und Süßstoffbehälter

PURE

toothpick- and sweetener box-holder
 porte-cure-dents et récipient pour sucrettes
 palillero y dispensador de edulcorante
 porta stuzzicadenti e contenitore per dolcificante

zum Einhängen in alle WMF PURE-Gestelle mit Bügelgriff.

Laser-Gravur der Tischnummer nach Wunsch - Preis auf Anfrage /
 fitting in all racks of WMF PURE sets. Engraving of the table No. on
 request - please ask for respective costs

Cromargan® / stainless 18/10

Höhe	height
cm	in.
4	1 1/2

06.1905.6044



Salzmühle / Pfeffermühle

salt mill / pepper mill
 moulin à sel / moulin à poivre
 molinillo sal / molinillo pimienta
 macinasale / macinapepe

mit original Keramikmahlwerk /
 with ceramic grinding mechanism

Cromargan®, Acrylglas / stainless 18/10, acrylic glass

Höhe	height	Ø	Ø
cm	in.	cm	in.
12	4 ³ / ₄	5	2
16	6 ¹ / ₄	5	2

06.1510.6040
06.3531.6040



Salzmühle / Pfeffermühle

salt mill / pepper mill
 moulin à sel / moulin à poivre
 molinillo sal / molinillo pimienta
 macinasale / macinapepe

mit original Keramikmahlwerk. Passend in die großen Ausschnitte der Menagen PURE EXCLUSIV /
 with ceramic grinding mechanism. Fitting in the big cut-outs of the stands high PURE EXCLUSIV

Cromargan®, Holz lackiert / stainless 18/10, wood lacquered

Höhe	height
cm	in.
19	7 ¹ / ₂

Salzmühle / Pfeffermühle metall /
 salt mill / pepper mill metal

06.6711.6040

Salzmühle / Pfeffermühle weiß /
 salt mill / pepper mill white

06.6708.4500

Salzmühle / Pfeffermühle schwarz /
 salt mill / pepper mill black

06.6709.4500

Salzmühle / Pfeffermühle rot /
 salt mill / pepper mill red

06.6710.4500



Salzstreuer / Pfefferstreuer
URBAN

salt shaker / pepper shaker
 moulin à sel / moulin à poivre
 molinillo sal / molinillo pimienta
 macinasale / macinapepe

einzelnd stehend oder passend auf Tablett URBAN oder in kleine Ausschnitte von PURE EXCLUSIV Teelichthalter und Menage. /
 stand alone or fitting on tray URBAN or in small cut-outs of PURE EXCLUSIV tealight holder or menage

Cromargan® / stainless 18/10

Höhe	height	Ø	Ø
cm	in.	cm	in.
8,5	3 ¹ / ₄	4,5	1 ³ / ₄

Salzstreuer / salt shaker

55.0062.6040

Pfefferstreuer / pepper shaker

55.0063.6040

Ersatzteil / spare part:

Stopfen zu Streuer / stopper for shakers

55.0062.9502



**Salz- und Pfeffergestell
CLASSIC**

salt-pepper-set
ménagère 2 pièces
servicio condimento
menage

Höhe	height
cm	in.
12,3	5

Cromargan®	versilbert
stainless 18/10	silverplated
06.5171.6040	19.5171.6440

Ersatzteil / spare part:
Salzstreuer / salt shaker
Pfefferstreuer / pepper shaker
Ersatzglas / spare glass

06.6037.6040	19.6037.6440
06.6038.6040	19.6038.6440
	60.6037.9990



**Salz- und Pfeffergestell
PURE**

salt-pepper-set
ménagère 2 pièces
servicio condimento
menage

Cromargan®, Kappen mattiert, Glas /
stainless 18/10, tops satin finished, glass

Höhe	height
cm	in.
14,5	5 ³ / ₄

06.5170.6040

Ersatzteil / spare part:
Salzstreuer / salt shaker
Pfefferstreuer / pepper shaker
Ersatzglas / spare glass

06.6062.6030
06.6063.6030
60.8253.9960



Salz- und Pfeffergestell

salt-pepper-set
ménagère 2 pièces
servicio condimento
menage

Cromargan®, Glas / stainless 18/10, glass

Höhe	height
cm	in.
12	4 ³ / ₄

06.6008.6040

Ersatzteil / spare part:
Salzstreuer / salt shaker
Pfefferstreuer / pepper shaker

06.6193.6040
06.6194.6040



**Essig-/Ölgestell
CLASSIC**

oil and vinegar set
huilier-vinaigrier
vinagreras
oliera

Höhe	height
cm	in.
23	9

Cromargan®	versilbert
stainless 18/10	silverplated
06.1906.6040	19.1906.6440

Ersatzteil / spare part:

Ersatzflasche / spare bottle			
Höhe	height	Inhalt	cap.
cm	in.	Ltr.	oz.
19	7,5	0,15	5,22

19.9999.8632

Essig-/Öl-Set URBAN

oil and vinegar set
huilier-vinaigrier
vinagreras
oliera

bestehend aus Tablett, Essig- und Ölflasche, Salz- und Pfefferstreuer. /
consisting of tray, oil and vinegar bottle, salt and pepper shaker

Cromargan®, Glas / stainless 18/10, glass



Tablett / tray 55.0058.6045

Essig-/Ölflasche / oil/vinegar bottle 55.0059.6040

Salzstreuer / salt shaker 55.0062.6040

Pfefferstreuer / pepper shaker 55.0063.6040

Ersatzteil / spare part:

Stopfen zu Streuer / stopper for shakers 55.0062.9502

Ausgießer zu Essig-/Ölflasche / 55.0059.9802

pourer for oil/vinegar bottle

Deckel zu Essig-/Ölflasche / 55.0059.6803

lid for oil/vinegar bottle

Tablett URBAN

tray
plateau
bandeja
vassoio

Cromargan® / stainless 18/10

Größe	size
cm	in.
23 x 10,7	8 x 4 1/4

55.0058.6045



Essig-/Ölflasche URBAN

oil/vinegar bottle
burette à vinaigre/huile
botella de aceite/vinagre
caraffa per aceto/olio

Cromargan®, Glas / stainless 18/10, glass

Höhe	height	Inhalt	cap.	Ø	Ø	
cm	in.	Ltr.	oz.	cm	in.	
15,2	6	0,15	5,07	5,7	2 1/4	55.0059.6040

Ersatzteil / spare part:

Ausgießer zu Essig-/Ölflasche / 55.0059.9802

pourer for oil/vinegar bottle

Deckel zu Essig-/Ölflasche / 55.0059.6803

lid for oil/vinegar bottle





Essig-/Öl-Menage

PURE

oil and vinegar set
huilier-vinaigrier
vinagreras
oliera

bestehend aus Gestell, Essig- und Ölflasche und Glasbehälter für Senf, Parmesan, Sambal Oelek u.a. /

Condiment set consisting of: stand, oil / vinegar bottle and glass pots for mustard, parmesan, relish, etc.

Cromargan®, Glas / stainless 18/10, glass

Gestell hoch / stand high

Höhe	height	Ø	Ø	
cm	in.	cm	in.	
21	8 ¹ / ₄	14	5 ¹ / ₂	06.2341.6045

einzelne Flasche komplett / spare bottle complete

Höhe	height	Inhalt	cap.	
cm	in.	Ltr.	oz.	
16	6 ¹ / ₂	0,2	6,96	06.6139.6030

Glas S / glass S

Höhe	height	Inhalt	cap.	
cm	in.	Ltr.	oz.	
7,4	3	0,09	3,2	60.2506.9990

Ring S / ring S **06.2502.6040**

Deckel mit Ausschnitt / lid with cut-out **55.0031.6040**

Espresso-/Mokkalöffel / demi-tasse spoon **54.9901.6040**



Essig-/Ölgestell, 4 tlg.

PURE

oil and vinegar set, 4 pcs.
huilier-vinaigrier, 4 parties
vinagreras, 4 piezas
oliera, a 4 vaschette

bestehend aus: Gestell, Essig- und Ölflasche, Salz- und Pfefferstreuer /
consisting of: stand, oil / vinegar bottle, salt / pepper shaker

Cromargan® / stainless 18/10

Höhe	height	Ø	Ø	
cm	in.	cm	in.	
21,1	8 ¹ / ₂	14	5 ¹ / ₂	06.2341.6040

Ersatzteil / spare part:

Gestell hoch / stand high **06.2341.6045**

Höhe	height	Ø	Ø
cm	in.	cm	in.
21	8 ¹ / ₄	14	5 ¹ / ₂

Salzstreuer / salt shaker **06.6062.6030**

Höhe	height
cm	in.
11	4 ¹ / ₄

Pfefferstreuer / pepper shaker **06.6063.6030**

Höhe	height
cm	in.
11	4 ¹ / ₄

einzelne Flasche komplett / spare bottle complete **06.6139.6030**

Höhe	height	Inhalt	cap.
cm	in.	Ltr.	oz.
16	6 ¹ / ₂	0,2	6,96



**Essig-/Ölgestell, 4tlg.
PURE EXCLUSIV**

oil and vinegar set, 4 pcs.
huilier-vinaigrier, 4 parties
vinagreras, 4 piezas
oliera, a 4 vaschette

Gestell mit 4 Einsätzen für Flaschen und Streuer. Nicht
spülmaschinengeeignet! /
stand with 4 inserts for bottles and shaker. Not dishwasher-safe!

Cromargan®, Holz dunkel gebeizt /
stainless 18/10, wood dark stained

Menage / stand

Größe cm	size in.	
14,5 x 14,5 x 25,4	5 ³ / ₄ x 5 ³ / ₄ x 10	55.0034.6040

einzelne Flasche komplett / spare bottle complete

Höhe cm	height in.	Inhalt Ltr.	cap. oz.	
16	6 ¹ / ₂	0,2	6,96	06.6139.6030

Salzstreuer / salt shaker

Höhe cm	height in.	
11	4 ¹ / ₄	06.6062.6030

Pfefferstreuer / pepper shaker

Höhe cm	height in.	
11	4 ¹ / ₄	06.6063.6030



**Essig-/Ölgestell, 4tlg.
PURE EXCLUSIV**

oil and vinegar set, 4 pcs.
huilier-vinaigrier, 4 parties
vinagreras, 4 piezas
oliera, a 4 vaschette

Gestell mit 4 Einsätzen für Flaschen, Streuer und Glas für Senf / Sambal
Oelek / Parmesan. Nicht spülmaschinengeeignet! /
stand with 4 inserts for bottles, shaker and glass for mustard / relish /
Parmesan. Not dishwasher-safe!

Cromargan®, Holz dunkel gebeizt /
stainless 18/10, wood dark stained

Menage / stand

Größe cm	size in.	
14,5 x 14,5 x 25,4	5 ³ / ₄ x 5 ³ / ₄ x 10	55.0034.6040

einzelne Flasche komplett / spare bottle complete

Höhe cm	height in.	Inhalt Ltr.	cap. oz.	
16	6 ¹ / ₂	0,2	6,96	06.6139.6030

Salzstreuer / salt shaker

Höhe cm	height in.	
11	4 ¹ / ₄	06.6062.6030

Glas S / glass S

Höhe cm	height in.	Inhalt Ltr.	cap. oz.	
7,4	3	0,09	3,2	60.2506.9990

Deckel mit Ausschnitt / lid with cut-out **55.0031.6040**

Espresso-/Mokkalöffel / demi-tasse spoon **54.9901.6040**



**Salz-/Pfeffer-Set
PURE EXCLUSIV**

salt and pepper set
huilier-vinaigrier
vinagreras
oliera

bestehend aus: Teelichtleuchter 3fl., Salz- und Pfefferstreuer und wahlweise Glasbehälter S, Porzellantasse S mit Deckel oder Porzellanschälchen für Saucen, Butter, Senf, Parmesan, Salz... / consisting of: tealight holder, oil/vinegar bottle and optional glass S or salt and pepper shaker, individually combined with porcelain cup S with lid or small porcelain bowl for sauce, butter, mustard, parmesan, salt, relish...

Cromargan®, Glas, Porzellan / stainless 18/10, glass, porcelain

Teelichtleuchter 3fl. klein / tealight candle stick, small

Größe	size	
cm	in.	
20,5 x 6,2 x 3,7	8 x 2 ¹ / ₂ x 1 ¹ / ₂	55.0039.6040

Salzstreuer / salt shaker

Höhe	height	
cm	in.	
11	4 ¹ / ₄	06.6062.6030

Pfefferstreuer / pepper shaker

Höhe	height	
cm	in.	
11	4 ¹ / ₄	06.6063.6030

Glas S / glass S

Höhe	height	Inhalt	cap.	
cm	in.	Ltr.	oz.	
7,4	3	0,09	3,2	60.2506.9990

Porzellantasse S / porcelain cup S

Höhe	height	Inhalt	cap.	
cm	in.	Ltr.	oz.	
7,4	3	0,09	3,2	60.2508.9990

Deckel mit Ausschnitt / lid with cut-out

55.0031.6040

Espresso-/Mokkalöffel / demi-tasse spoon

54.9901.6040

Porzellanschälchen (6er) / porcelain bowl (6 pcs.)

Höhe	height	Ø	Ø	
cm	in.	cm	in.	
4	1 ¹ / ₂	5	2	55.0093.9990

Gewürzlöffel / spicy spoon

54.9184.6040

Menage PURE EXCLUSIV

menage
menagère, à tapenades
set 3 recipientes
ménage per tapenade

für Tapenade, Fleur de Sel oder Saucen und Dips /
for tapenade, fleur de sel or dips

Cromargan®, Holz dunkel gebeizt /
stainless 18/10, wood dark stained



Teelichtleuchter 3fl. klein / tealight candle stick, small

Größe	size	
cm	in.	
20,5 x 6,2 x 3,7	8 x 2 1/2 x 1 1/2	

55.0039.6040

Porzellanschälchen (6er) / porcelain bowl (6 pcs.)

Höhe	height	Ø	Ø
cm	in.	cm	in.
4	1 1/2	5	2

55.0093.9990

Gewürzlöffel / spicy spoon

Länge	length
cm	in.
7	2 3/4

54.9184.6040

Essig-/Ölgestell PURE

oil and vinegar set
huilier-vinaigrier
vinagreras
oliera

Cromargan®, Kappen mattiert, Glas /
stainless 18/10, tops satin finished, glass

Höhe	height
cm	in.
21	8 1/4

06.1905.6040



Ersatzteil / spare part:

einzelne Flasche komplett / spare bottle complete

06.6139.6030

Ersatzflasche / spare bottle

60.8254.9960

Ausgießer / pouring stopper

60.8255.9990

Zahnstocher- und Süßstoffbehälter PURE

toothpick- and sweetener box-holder
porte-cure-dents et récipient pour sucrètes
palillero y dispensador de edulcorante
porta stuzzicadenti e contenitore per dolcificante

zum Einhängen in alle WMF PURE-Gestelle mit Bügelgriff.

Laser-Gravur der Tischnummer nach Wunsch - Preis auf Anfrage /
fitting in all racks of WMF PURE sets. Engraving of the table No. on
request - please ask for respective costs

Cromargan® / stainless 18/10

Höhe	height
cm	in.
4	1 1/2

06.1905.6044





**Senftopf
CLASSIC**

mustard pot
moutardier
mostacero
senapiera

Cromargan® / stainless 18/10

Höhe	height
cm	in.
9	3 1/2

06.6965.6040

Ersatzteil / spare part:
Ersatzglas / spare glass

19.9999.8639



**Käsedose
CLASSIC**

parmesan jar
fromagère
recipiente
formaggiera

mit Kristalleinsatz /
with crystal insert

Cromargan® / stainless 18/10

Ø	Ø
cm	in.
15,5	6

06.2885.6040

Ersatzteil / spare part:
Ersatzglas / spare glass

19.9999.8637



**Käsedose
NEUTRAL**

parmesan jar
fromagère
recipiente
formaggiera

mit Kristalleinsatz /
with crystal insert

Cromargan® / stainless 18/10

Ø	Ø
cm	in.
14,5	5 3/4

06.2868.6040

Ersatzteil / spare part:
Ersatzglas / spare glass
Deckel / cover
Unterteller / underliner

60.8025.9990

06.2868.6042

06.1089.6043

BUFFET

combiNation buffet

Warmhalten

keeping warm

Dosieren

portioning

Präsentieren

presenting



combiNation buffet

einfach auf die Schiene
bringen
the easiest way to get
your buffet on track

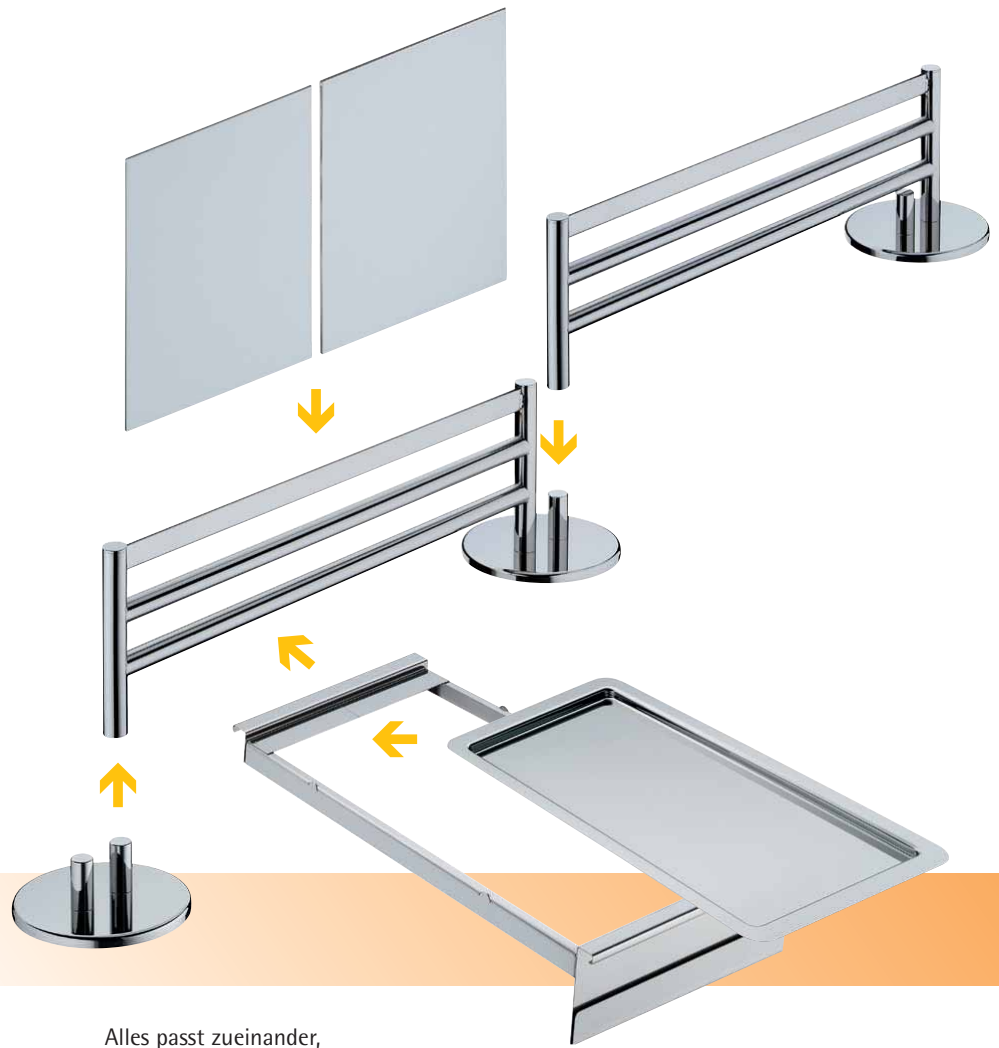

Alles passt zueinander,
alles passt ineinander
Everything fits together,
everything fits in

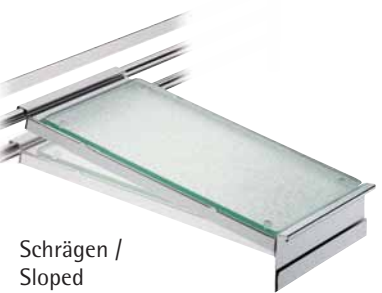

Schrägen /
Sloped



Stufen /
Stepped



Ihrer Phantasie sind keine Grenzen gesetzt -
There are no limits to your imagination





Produktvorteile

einfach und genial

Das gesamte Buffet wird in Schienen eingehängt. Selbst ungeübte Mitarbeiter erledigen den Umbau intuitiv. Sparen Sie Zeit und schaffen Sie sich Freiraum für die wirklich wichtigen Dinge.

einfach variabel und leicht bedienbar

Alles passt zueinander, hier können Sie kreativ sein. Kein Kaschieren, kein Verstecken - stilsicher bei jedem Aufbau. Der Gesamteindruck ist harmonisch aufeinander abgestimmt. Verschiedene Ebenen und Schrägen, integrierte Beschilderung, unterschiedliche Einsätze - alles lässt sich spielend leicht kombinieren.

einfach alles weiterverwenden

Ihre bereits vorhandenen Gastronormbehälter, Ihre Tablettts, Chafing Dishes und Einsätze - alles kann problemlos eingesetzt werden.

einfach heiß und kalt

Je nach Tageszeit und Speisenauswahl - Sie entscheiden über perfekte Kühlung in der Eiswanne oder gleichmäßiges Warmhalten mit den entsprechenden Heizelementen.

einfach platzsparend und ordentlich

Durch die optimierte Anordnung profitieren Sie von einer enormen Platzersparnis, auch in der größten Hektik - alles bleibt ordentlich, appetitlich und sauber.

einfach alles gesagt

Die ansprechende Präsentation der Speisen anhand der eingesteckten Bilder oder Tafeln sind nicht nur leicht verständlich, sie dienen auch als Appetitanreger und Werbefläche. Auch bei geschlossenen Behältnissen.

Advantages of the products

simply brilliant

The whole buffet is suspended from rails. Even untrained staff will be able to set it up intuitively. You'll save time and free yourself up to do the things that really matter.

simply versatile and easy to use

Everything fits together, so you can be creative. No need to disguise or conceal anything - making a stylish statement. The overall impression is harmonious and coordinated. Different levels and gradients, integral labelling, various inserts - they can all be combined effortlessly.

simply reuse everything

Your existing Gastronorm containers, your trays, chafing dishes and inserts - they can all be used without any problem.

simply hot and cold

According to the time of day and choice of dishes - you choose whether to have them perfectly chilled in the ice tray or keep them consistently warm by using the appropriate heating elements.

simply neat and organised

The compact arrangement saves you a huge amount of space, even at the busiest times - everything is always tidy, appetising and clean.

simply says it all

The attractive presentation using picture inserts or boards not only provides a see-at-a-glance guide to the dishes, it also whets the appetite and creates an advertising space. Even when the containers are closed.

**Grundreling L**

basic rail L
support 3 barres de base L
soporte principal L
unità base L

passend für 3 Rahmen und 3 Bilder oder Tafeln, bestehend aus 1 x Reling, 2 x Fuß, 2 x Abdeckkappe /
fits for 3 frames and 3 pictures or boards, consisting of 1 x rail, 2 x foot, 2 x cap

Cromargan® / stainless 18/10

Höhe cm	height in.	Ø Fuß cm	Ø base in.
22,6	9	20	8

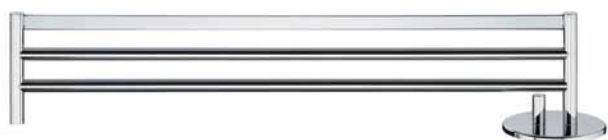
06.2410.6040**Erweiterungsreling L**

extension rail L
support 3 barres supplémentaire L
soporte adicional L
estensione L

passend für 3 Rahmen und 3 Bilder oder Tafeln, bestehend aus 1 x Reling, 1 x Fuß, 2 x Abdeckkappe /
fits for 3 frames and 3 pictures or boards, consisting of 1 x rail, 1 x foot, 2 x cap

Cromargan® / stainless 18/10

Höhe cm	height in.	Ø Fuß cm	Ø base in.
22,6	9	20	8

06.2412.6040

Ersatzteil / spare part:

Reling L / rail L	06.2410.6042
Fuß / foot	06.2410.6041
Abdeckkappe / cap	06.2410.6043

**Grundreling M**

basic rail M
support 3 barres de base M
soporte principal M
unità base M

passend für 2 Rahmen und 2 Bilder oder Tafeln, bestehend aus 1 x Reling, 2 x Fuß, 2 x Abdeckkappe /
fits for 2 frames and 2 pictures or boards, consisting of 1 x rail, 2 x foot, 2 x cap

Cromargan® / stainless 18/10

Höhe cm	height in.	Ø Fuß cm	Ø base in.
22,6	9	20	8

06.2411.6040

Erweiterungsreling M

extension rail M
support 3 barres supplémentaire M
soporte adicional M
estensione M

passend für 2 Rahmen und 2 Bilder oder Tafeln, bestehend aus 1 x Reling, 1 x Fuß, 2 x Abdeckkappe /
fits for 2 frames and 2 pictures or boards, consisting of 1 x rail, 1 x foot, 2 x cap



Cromargan® / stainless 18/10

Höhe cm	height in.	Ø Fuß cm	Ø base in.
22,6	9	20	8

06.2413.6040

Ersatzteil / spare part:

Reling M / rail M	06.2411.6042
Fuß / foot	06.2410.6041
Abdeckkappe / cap	06.2410.6043

Chafing Dish, GN 1/1

Chafing Dish, GN 1/1
Chafing Dish, GN 1/1
Chafing Dish, GN 1/1
Chafing Dish, GN 1/1

passend für Einsätze bis Tiefe 10 cm. Bitte Heizelement und Einsätze separat bestellen. Passende Einsätze s. Chafing Dish Katalog /
fitting for inserts up to depth 4 in. Please order heating element and inserts separately. Suitable inserts in chafing dish catalogue

GN 1/1, Klappdeckel, elektrisch beheizbar /
GN 1/1, cover, electrically heated

Cromargan® / stainless 18/10

komplett ohne Einsätze / complete w/o inserts

Höhe Deckel hochgeklappt cm	height cover lifted in.	Größe mit Deckel und Griff cm	size w. cover a. handle in.
61	24	62 x 34,5 x 20	24 ¹ / ₂ x 13 ¹ / ₂ x 8

06.2446.6040

Zubehör / accessory:

Heizelement 230 V / 600 W / heating element 230 V / 600 W	55.0097.6044
Heizelement 120 V / 600 W / heating element 120 V / 600 W	55.0097.9990
Heizelement 230 V / 700 W mit Regler / heating element 230 V / 700 W heat adjustable	06.3286.6046





Chafing Dish, GN 1/1

Chafing Dish, GN 1/1
 Chafing Dish, GN 1/1
 Chafing Dish, GN 1/1
 Chafing Dish, GN 1/1

passend für Einsätze bis Tiefe 10 cm. Bitte Heizelement und Einsätze separat bestellen. Passende Einsätze s. Chafing Dish Katalog / fitting for inserts up to depth 4 in.

Please order heating element and inserts separately. Suitable inserts in chafing dish catalogue

GN 1/1, Klappdeckel, elektrisch beheizbar / GN 1/1, cover, electrically heated

Cromargan® / stainless 18/10
 komplett ohne Einsätze / complete w/o inserts

Höhe Deckel hochgeklappt	height cover lifted	Größe mit Deckel und Griff	size w. cover a. handle	
cm	in.	cm	in.	
74	29	62 x 34,5 x 20	24 1/2 x 13 1/2 x 8	06.2423.6040

Zubehör / accessory:

Heizelement 230 V / 600 W / heating element 230 V / 600 W	55.0097.6044
Heizelement 120 V / 600 W / heating element 120 V / 600 W	55.0097.9990
Heizelement 230 V / 700 W mit Regler / heating element 230 V / 700 W heat adjustable	06.3286.6046



Chafing Dish, GN 1/1

Chafing Dish, GN 1/1
 Chafing Dish, GN 1/1
 Chafing Dish, GN 1/1
 Chafing Dish, GN 1/1

passend für Einsätze bis Tiefe 10 cm. Bitte Brennstoffdosenthaler und Einsätze separat bestellen. Passende Einsätze s. Chafing Dish Katalog / fitting for inserts up to depth 4 in. Please order burner holder and inserts separately. Suitable inserts in chafing dish catalogue

GN 1/1, Klappdeckel, Brennstoff beheizbar / GN 1/1, cover, sterno heated

Cromargan® / stainless 18/10
 komplett ohne Einsätze / complete w/o inserts

Höhe Deckel hochgeklappt	height cover lifted	Größe mit Deckel und Griff	size w. cover a. handle	
cm	in.	cm	in.	
82,5	32 1/2	62 x 34,5 x 28,5	24 1/2 x 13 1/2 x 11 1/4	06.2442.6040

Zubehör / accessory:

Brennstoffdosenthaler / burner holder	06.2442.6039
Brennstoffdose / solid alcohol Inhalt	60.3002.0690
Ltr. / oz.	
je Dose 0,2 / each tin 7	





Heizelement

heating element
 plaque électrique
 placa calentadora
 piastra riscaldante

für WMF Chafing Dishes GN $\frac{1}{1}$ und GN $\frac{2}{3}$, VDE geprüft /
 suitable for WMF chafing dishes GN $\frac{1}{1}$ and GN $\frac{2}{3}$, VDE proved

Größe	size
cm	in.
25 x 20	9 $\frac{3}{4}$ x 7 $\frac{3}{4}$

Heizelement 230 V / 600 W /
 heating element 230 V / 600 W

55.0097.6044

Heizelement 120 V / 600 W /
 heating element 120 V / 600 W

55.0097.9990

Heizelement 230 V / 700 W mit Regler /
 heating element 230 V / 700 W heat adjustable

06.3286.6046

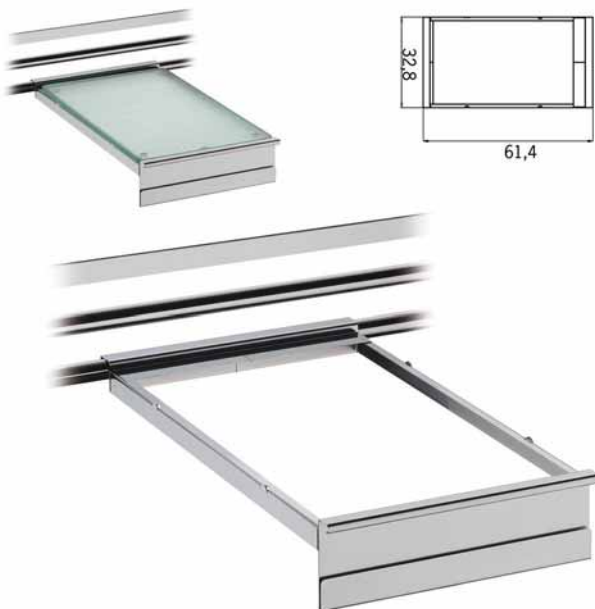

Rahmen, GN $\frac{1}{1}$ mittel

frame, GN $\frac{1}{1}$ medium
 cadre, GN $\frac{1}{1}$ moyen
 marco, GN $\frac{1}{1}$ medio
 telaio, GN $\frac{1}{1}$ medio

passend für Einsätze GN $\frac{1}{1}$, GN $\frac{2}{3}$, GN $\frac{1}{2}$, GN $\frac{1}{3}$, GN $\frac{2}{4}$
 (max. 6,5 cm tief) /
 fitting for inserts GN $\frac{1}{1}$, GN $\frac{2}{3}$, GN $\frac{1}{2}$, GN $\frac{1}{3}$, GN $\frac{2}{4}$
 (max. 2 $\frac{1}{2}$ in. deep)

Cromargan® / stainless 18/10

Höhe	height
cm	in.
10	4

06.2420.6040

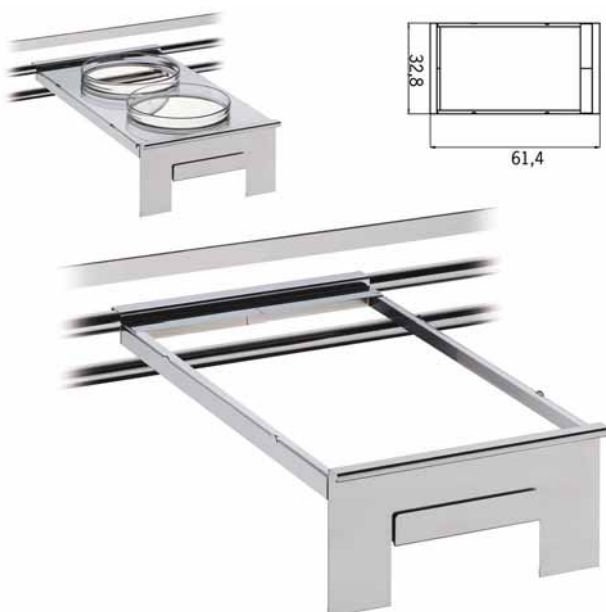

Rahmen, GN $\frac{1}{1}$ hoch

frame, GN $\frac{1}{1}$ high
 cadre, GN $\frac{1}{1}$ haut
 marco, GN $\frac{1}{1}$ alto
 telaio, GN $\frac{1}{1}$ alto

passend für Einsätze GN $\frac{1}{1}$, GN $\frac{2}{3}$, GN $\frac{1}{2}$, GN $\frac{1}{3}$, GN $\frac{2}{4}$
 (max. 10 cm tief) /
 fitting for inserts GN $\frac{1}{1}$, GN $\frac{2}{3}$, GN $\frac{1}{2}$, GN $\frac{1}{3}$, GN $\frac{2}{4}$
 (max. 4 in. deep)

Cromargan® / stainless 18/10

Höhe	height
cm	in.
16	6 $\frac{1}{4}$

06.2421.6040

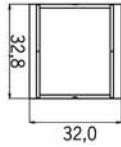

Rahmen, GN 1/2 mittel

frame, GN 1/2 medium

cadre, GN 1/2 moyen

marco, GN 1/2 medio

telaio, GN 1/2 medio

passend für Einsätze GN 1/2 (max. 6,5 cm tief) /
fitting for inserts GN 1/2 (max. 2 1/2 in. deep)

Cromargan® / stainless 18/10

Höhe	height
cm	in.
10	4

06.2417.6040

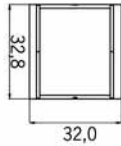

Rahmen, GN 1/2 hoch

frame, GN 1/2 high

cadre, GN 1/2 haut

marco, GN 1/2 alto

telaio, GN 1/2 alto

passend für Einsätze GN 1/2 (max. 10 cm tief) /
fitting for inserts GN 1/2 (max. 4 in. deep)

Cromargan® / stainless 18/10

Höhe	height
cm	in.
16	6 1/4

06.2418.6040



- **CORIAN® von DuPont** ist ein idealer Verbundwerkstoff, welcher die Vorteile von natürlichen Materialien und reinem Acrylpolymer kombiniert. Es bietet Funktionalität, Ästhetik und Hygiene zugleich. CORIAN® ist ein Warenzeichen von DuPont – Nur DuPont stellt CORIAN® her.
- **Fleckenabweisend / pflegeleicht:** CORIAN® kann einfach mit herkömmlichen Haushaltsreinigern gereinigt werden.
- **Hygienisch / lebensmittelgeeignet:** CORIAN® entspricht dem Lebensmittelgesetz § 30/31, Abs.1 für alle Nahrungsmittelbereiche. CORIAN® ist porenfrei, wodurch Pilze, Schimmel, Bakterien und andere Keime keinen Halt finden.
- **Kälte / Hitze:** CORIAN® speichert Kälte über einen längeren Zeitraum. CORIAN® ist hitzefest bis 75°C. Es sollten jedoch keine heißen Töpfe oder andere hitzeabgebende Gegenstände direkt auf das Material gestellt werden.
- **Material:** CORIAN® ist ungiftig, chemisch stabil und antiallergisch. CORIAN® gibt bei Raumtemperatur praktisch keine flüchtigen Stoffe oder Gase ab.

- **CORIAN® by DuPont** is an ideal composite material, combining the advantages of natural materials and pure acrylic polymer. The result is practicality, great looks and hygiene all in one. CORIAN® is a registered trade mark of DuPont – only DuPont makes CORIAN®.
- **Stain-repellent / easy-care:** CORIAN® is easy to clean, using standard household cleaning products.
- **Hygienic / food-safe:** CORIAN® complies with the German Foodstuffs Act sections 30/31, subsection 1 for all food areas. CORIAN® is non-porous, and therefore fungi, mould, bacteria and other germs cannot get a hold.
- **Cold / heat:** CORIAN® stores cold for a fairly long time. CORIAN® is heat-resistant up to 75°C. However, hot saucepans or other heat-releasing objects should not be placed directly on the material.
- **Material:** CORIAN® is non-toxic, chemically stable and non-allergenic. CORIAN® releases practically no volatile substances or gases at room temperature.

- **CORIAN® de DuPont** est un alliage qui réunit les avantages des matériaux naturels et des polymères acryliques. Il garantit à la fois fonctionnalité, esthétisme et hygiène. CORIAN® est une marque déposée par DuPont. – Seule DuPont la produit.
- **Anti-taches et facile d'entretien:** L'entretien de CORIAN® se fait avec des produits ménagers usuels.
- **Conforme aux normes d'hygiène en vigueur:** CORIAN® est conforme à la loi allemande sur les denrées alimentaires, art. 30/31, alinéa 1 pour tous les domaines des denrées alimentaires. CORIAN® n'est pas poreux ce qui empêche tout développement de bactéries, de moisissures et autres.
- **Températures extrêmes:** CORIAN® garde le froid pendant une durée importante. CORIAN® est résistant à la chaleur jusqu'à 75°C. Il est cependant déconseillé de poser des récipients chauds ou d'autres objets chauffants directement à son contact.
- **Matériau:** CORIAN® est neutre, chimiquement stable et anti-allergique. A température ambiante, CORIAN® ne dégage pratiquement aucun gaz.

- **CORIAN® de DuPont** es una combinación ideal entre materiales naturales y polímero acrílico puro, ofreciendo funcionalidad, estética e higiene. CORIAN® es marca registrada de DuPont – y solo DuPont fabrica CORIAN®.
- **Repele las manchas y es fácil de limpiar:** CORIAN® se limpia fácilmente con los detergentes habituales como por ejemplo lavavajillas o jabón.
- **Higiénico / apto para alimentos:** CORIAN® cumple con la reglamentación sobre alimentos 30/31, apto. 1 y es apto para todos los alimentos. CORIAN® no es poroso por lo que no existe el peligro de que se adhieren hongos, moho, bacterias o gérmenes en su superficie.
- **Frío / Calor:** CORIAN® conserva el frío durante un largo período de tiempo. CORIAN® es resistente al calor a 75°C. No obstante, debe evitar el contacto directo con cosas calientes u otros cuerpos que presenten una elevada temperatura.
- **Material:** CORIAN® no es tóxico, químicamente estable y no produce alergias. CORIAN® prácticamente no desprende gases ni olor si se encuentra a una temperatura de ambiente normal.

- **CORIAN® di DuPont** è un'avanzata combinazione di materiali naturali e puro polimero acrilico in grado di offrire funzionalità, estetica ed igiene. CORIAN® è un marchio di fabbrica di DuPont – Solo DuPont produce CORIAN®.
- **Manutenzione:** CORIAN® è antimacchia e si pulisce facilmente con i tradizionali detergenti per la casa.
- **Igiene / Idoneo per alimenti:** CORIAN® è conforme alla legge sugli alimenti §30/31, comma 1, ed è idoneo per tutti i settori alimentari. Omogeneo, impermeabile e privo di pori, CORIAN® impedisce la proliferazione di funghi, muffe, batteri ed altri germi.
- **Condizione termica:** CORIAN® accumula a lungo il freddo ed è resistente al calore fino 75°C. E' comunque opportuno non porre direttamente a contatto del materiale pentole bollenti o altri oggetti che emanano calore intenso.
- **Affidabilità:** CORIAN® è atossico, antiallergico, chimicamente stabile e non rilascia sostanze né gas.

**Platte, GN 1/1, CORIAN®**

platter, GN 1/1, CORIAN®
 planche pour recipient, GN 1/1, CORIAN®
 fuente, GN 1/1, CORIAN®
 piatto, GN 1/1, CORIAN®

passend auf alle GN 1/1 Rahmen /
 fitting on all GN 1/1 frames

spülmaschinenfest /
 dishwasher-safe

CORIAN®

Größe cm	size in.
53 x 32,5	20 ³ / ₄ x 12 ³ / ₄

06.2431.9990**Tablett, rechteckig, Gastronorm**

serving tray, rectangular, Gastronorm
 plateau de service, rectangulaire, Gastronorm
 bandeja, rectangular, Gastronorm
 vassoio, rettangolare, Gastronorm

Passend auf alle GN 1/1 Rahmen von combiNation buffet /
 fitting on all GN 1/1 frames of combiNation buffet

GN 1/1, stapelbar, rechteckig, schnittfest, spülmaschinenfest /
 GN 1/1, stackable, rectangular, resistant against cutting, dishwasher-safe

Kunststoff, Cromargan® - Griffe /
 high quality plastic, handle stainless 18/10

Größe cm	size in.
53 x 32,5	20 ³ / ₄ x 12 ³ / ₄

06.7683.6040**Platte, GN Kunststoff**

platter Gastronorm, acrylic
 planche Gastronorm pour recipient, plastique
 fuente Gastronorm, plastico transparente
 piatto Gastronorm, materiale sintetico

schnittfest, spülmaschinenfest /
 resistant against cutting, dishwasher-safe

Kunststoff / plastic

	Größe cm	size in.	
GN 1/2*	32,5 x 26,5	12 ³ / ₄ x 10 ¹ / ₂	06.2433.9990
GN 1/1**	53 x 32,5	20 ³ / ₄ x 12 ³ / ₄	06.2432.9990

* Passend auf alle GN 1/2 Rahmen /
 fitting on all GN 1/2 frames

** Passend auf alle GN 1/1 Rahmen /
 fitting on all GN 1/1 frames



Tablett, Gastronorm

serving tray, Gastronorm
 plateau de service, Gastronorm
 bandeja, Gastronorm
 vassoio, Gastronorm

rechteckig /
 rectangular

Cromargan® / stainless 18/10

	Größe cm	size in.	
GN 1/2*	32,5 x 26,5	12 ³ / ₄ x 10 ¹ / ₂	06.7658.6040
GN 1/1**	53 x 32,5	20 ³ / ₄ x 12 ³ / ₄	06.7660.6040

* Passend auf alle GN 1/2 Rahmen / fitting on all GN 1/2 frames

** Passend auf alle GN 1/1 Rahmen / fitting on all GN 1/1 frames



Tablett, Gastronorm, RESIDENCE

serving tray, Gastronorm
 plateau de service, Gastronorm
 bandeja, Gastronorm
 vassoio, Gastronorm

Rand dekoriert, rechteckig /
 rim decorated, rectangular

Cromargan® / stainless 18/10

	Größe cm	size in.	
GN 1/1*	53 x 32,5	20 ³ / ₄ x 12 ³ / ₄	06.7744.6040
GN 2/1	65 x 53	25 ¹ / ₂ x 20 ³ / ₄	06.7745.6040

* Passend auf alle GN 1/1 Rahmen von combiNation buffet / fitting on all GN 1/1 frames of combiNation buffet



Tablett, Gastronorm, CLASSIC

serving tray, Gastronorm
 plateau de service, Gastronorm
 bandeja, Gastronorm
 vassoio, Gastronorm

Passend auf alle GN 1/1 Rahmen von combiNation buffet /
 fitting on all GN 1/1 frames of combiNation buffet

GN 1/1, rechteckig /
 GN 1/1, rectangular

Größe cm	size in.	Cromargan® stainless 18/10	versilbert silverplated
53 x 32,5	20 ³ / ₄ x 12 ³ / ₄	06.7849.6040	19.7849.6440

**Abdeckhaube**

cover for trays
cloche pour plateaux
campana para bandejas
coperchio adatto per vassoio

mit 2 seitlichen Eingriffen, passend für Tablett GN 1/1 ohne Griffe /
with two side openings, fitting for trays GN 1/1 without handles

Kunststoff glasklar, Griff verchromt /
high quality plastic, handle chrome plated

Höhe cm	height in.	Größe cm	size in.
14,5	5 ³ / ₄	55,5 x 35	21 ³ / ₄ x 13 ³ / ₄

06.2937.6040**Eiswanne, Gastronorm 1/1**

ice tray, Gastronorm 1/1
bac réfrigérant, Gastronorm 1/1
bandeja para hielo, Gastronorm 1/1
vasca per ghiaccio, Gastronorm 1/1

Passend in GN 1/1 Rahmen mittel und hoch. Es passen Brillen und
Tabletts. GN-Behälter passen **nicht** in die Eiswannen. /
Fitting for frames GN 1/1 medium and high. Suitable for all insert
holders and trays. GN-inserts do **not** fit in the ice trays.

GN 1/1, spülmaschinenfest /
GN 1/1, dishwasher-safe

ABS Kunststoff schwarz / ABS black plastic

	Größe cm	size in.	
①	53 x 32,5 x 7,5	20 ³ / ₄ x 12 ³ / ₄ x 3	06.2426.9990
②	53 x 32,5 x 14	20 ³ / ₄ x 12 ³ / ₄ x 5 ¹ / ₂	06.2450.9990



Eiswanne, Gastronorm 1/2

ice tray, Gastronorm 1/2
 bac réfrigérant, Gastronorm 1/2
 bandeja para hielo, Gastronorm 1/2
 vasca per ghiaccio, Gastronorm 1/2

Passend in GN 1/2 Rahmen mittel und hoch. Es passen Brillen und Tablets bis max. GN 1/2. GN-Behälter passen **nicht** in die Eiswannen. /
 Fitting for frames GN 1/2 medium and high. Suitable for all insert holders and trays till max. GN 1/2. GN-inserts do **not** fit in the ice trays.

GN 1/2, spülmaschinenfest /
 GN 1/2, dishwasher-safe

ABS Kunststoff schwarz / ABS black plastic

	Größe cm	size in.	
①	32,5 x 26,5 x 7,5	12 ³ / ₄ x 10 ¹ / ₂ x 3	06.2452.9990
②	32,5 x 26,5 x 14	12 ³ / ₄ x 10 ¹ / ₂ x 5 ¹ / ₂	06.2451.9990



Kühlakku, Gastronorm 1/2

cooling block, Gastronorm 1/2
 brique réfrigérante, Gastronorm 1/2
 acumulador refrigerador, Gastronorm 1/2
 tavoletta per il ghiaccio, Gastronorm, 1/2

1 Stück für Eiswannen GN 1/2, 2 Stück für Eiswannen GN 1/1 /
 1 pc. for ice trays GN 1/2, 2 pcs. for ice trays GN 1/1

Kunststoff mit Kühlflüssigkeit / plastic with cooling liquid

Größe cm	size in.	
25,5 x 20,3 x 3,2	10 x 8 x 1 ¹ / ₄	60.3065.9990



Tropfblech, GN 1/2

drainer, GN 1/2
 égouttoir, GN 1/2
 rejilla bandeja goteo, GN 1/2
 griglia, GN 1/2

Cromargan® / stainless 18/10

Größe cm	size in.	
26,5 x 32,8 x 1	10 ¹ / ₂ x 13 x 1/2	06.8234.6040

**Glaskrug**

glass pitcher
broc en verre
jarra de cristal
brocca di vetro

2 Stück passen in die Eiswannen GN 1/2, 4 St. in GN 1/1 /
2 pcs. fitting in ice trays GN 1/2, 4 St. in GN 1/1

Glas / glass

Höhe cm	height in.	Inhalt Ltr.	cap. oz.	
20	7 ³ / ₄	0,7	23,45	09.4115.2000
25,5	10	1	33,8	09.4116.2000
30	11 ³ / ₄	2	67	09.4117.2000

**Brille, GN 1/1 für 2 Gefäße**

insert holder, GN 1/1 for 2 inserts
support, GN 1/1 pour 2 becs
soporte, GN 1/1 para 2 recipientes
supporto, GN 1/1 per 2 contenitori

Passend auf alle GN 1/1 Rahmen und auf Eiswannen GN 1/1.
Mögliche Einsätze: Glasschale Ø 23 cm, große Porzellankugel /
Fitting on all GN 1/1 frames and on ice trays GN 1/1.
Suitable inserts: glass bowl Ø 9 in., porcelain bowl XL

2 Ausschnitte Ø je 22,2 cm, spülmaschinenfest /
2 cut outs Ø 8³/₄ in. each, dishwasher-safe

Cromargan® / stainless 18/10

Größe cm	size in.
53 x 33,3	20 ³ / ₄ x 13

06.2436.6040

**Brille, GN 1/2 für 1 Gefäß**

insert holder, GN 1/2 for 1 insert
support, GN 1/2 pour 1 bec
soporte, GN 1/2 para 1 recipiente
supporto, GN 1/2 per 1 contenitore

Passend auf alle GN 1/2 Rahmen und auf Eiswannen GN 1/2.
Mögliche Einsätze: Glasschale Ø 23 cm, große Porzellankugel /
Fitting on all GN 1/2 frames and on ice trays GN 1/2.
Suitable inserts: glass bowl Ø 9 in., porcelain bowl XL

1 Ausschnitt Ø 22,2 cm, spülmaschinenfest /
1 cut out Ø 8³/₄ in. each, dishwasher-safe

Cromargan® / stainless 18/10

Größe cm	size in.
33,3 x 26,5	13 x 10 ¹ / ₂

06.2434.6040



Porzellankugel, groß

porcelain bowl, XL
boule porcelaine, XL
bola de porcelana, XL
sfera in porcellana, XL

Passend in Etagegärenring, in alle Brillen mit großen Ausschnitten
Ø 22,2 cm auf mittleren und hohen Rahmen. /
Fitting in etagere ring, in all insert holders with big cut out
Ø 8³/₄ in. on frames medium and high.

Inhalt	cap.
Ltr.	oz.
3,5	122,5

60.3060.9990



Glasschale, 23 cm

glass bowl, 23 cm
bol à verre, 23 cm
depósitos de cristal, 23 cm
interno in vetro, 23 cm

Passend in Eiswannen mit Crush Eis, in alle Brillen mit großen
Ausschnitten Ø 22,2 cm auf mittleren und hohen Rahmen. /
Fitting in ice trays with crush ice, in all insert holders with big cut out
Ø 8³/₄ in. on frames medium and high.

Ø	Ø
cm	in.
23	9

19.9999.8673



Deckel zu Glasschale

lid for glass bowl
couvercle pour bol à verre
tapa para depósitos de cristal
coperchio per coppa in vetro

Einfach zu öffnen durch Drehen. Passend auf Glasschale Ø 23 cm
19.9999.8673 /
Easy to open by turning. Fitting on glass bowl Ø 9 in. 19.9999.8673

Cromargan® / stainless 18/10
Ø Ø
cm in.
23 9

06.2436.6042



Brille, GN 1/1 für 8 Gefäße

insert holder, GN 1/1 for 8 inserts
 support, GN 1/1 pour 8 becs
 soporte, GN 1/1 para 8 recipientes
 supporto, GN 1/1 per 8 contenitori

Passend auf alle GN 1/1 Rahmen und auf Eiswannen GN 1/1.
 Mögliche Einsätze: Dressingbehälter, Glasschale 12 cm, Beilagenschale /
 Fitting on all GN 1/1 frames and on ice trays GN 1/1.
 Suitable inserts: dressing bowl, small glass bowl 12 cm, small metal bowl

8 Ausschnitte Ø je 11,5 cm, spülmaschinenfest /
 8 cut outs Ø 4 1/2 in. each, dishwasher-safe

Cromargan® / stainless 18/10

Größe	size
cm	in.
53 x 33,3	20 3/4 x 13

06.2437.6040



Brille, GN 1/2 für 4 Gefäße

insert holder, GN 1/2 for 4 inserts
 support, GN 1/2 pour 4 becs
 soporte, GN 1/2 para 4 recipientes
 supporto, GN 1/2 per 4 contenitori

Passend auf alle GN 1/2 Rahmen und auf Eiswannen GN 1/2.
 Mögliche Einsätze: Dressingbehälter, Glasschale 12 cm, Beilagenschale /
 Fitting on all GN 1/2 frames and on ice trays GN 1/2.
 Suitable inserts: dressing bowl, small glass bowl 12 cm, small metal bowl

4 Ausschnitte Ø je 11,5 cm, spülmaschinenfest /
 4 cut outs Ø 4 1/2 in. each, dishwasher-safe

Cromargan® / stainless 18/10

Größe	size
cm	in.
33,3 x 26,5	13 x 10 1/2

06.2435.6040



Glasschale, 12 cm

glass bowl, 12 cm
 bol à verre, 12 cm
 depósitos de cristal, 12 cm
 interno in vetro, 12 cm

Passend in alle Brillen mit kleinen Ausschnitten Ø 11,4 cm auf mittleren und hohen Rahmen. /
 Fitting in all insert holders with small cut out Ø 4 1/2 in. on frames medium and high.



Ø	Ø
cm	in.
12	4 3/4

19.9999.8672



Porzellankugel, klein

porcelain bowl, S
boule porcelaine, S
bola de porcelana, S
sfera in porcellana, S

Passend in alle Brillen mit kleinen Ausschnitten Ø 11,5 cm auf mittleren und hohen Rahmen. /

Fitting in all insert holders with small cut out Ø 4 1/2 in. on frames medium and high.

Inhalt	cap.
Ltr.	oz.
0,5	17,5

60.3058.9990



Beilagenschale

bowl for ingredients
bol de acero
bol de acero
interno in vetro

Passend in alle Brillen mit kleinen Ausschnitten Ø 11,5 cm auf mittleren und hohen Rahmen. /

Fitting in all insert holders with small cut out Ø 4 1/2 in. on frames medium and high.

Cromargan® / stainless 18/10

Ø	Ø
cm	in.
11,4	4 1/2

06.0315.6040



Dressingbehälter

dressing insert
garniture pour saucière
recipiente para salsas
contenitore per salsa

Passend in alle Brillen mit kleinen Ausschnitten Ø 11,5 cm auf mittleren und hohen Rahmen und in Eiswannen tief von combiNATION buffet. /

Fitting in all insert holders with small cut out Ø 4 1/2 in. on frames medium and high and in ice trays deep of combiNATION buffet.

Cromargan® / stainless 18/10

Inhalt	cap.	Ø	Ø
Ltr.	oz.	cm	in.
1	35	11,4	4 1/2

06.1762.6043



Einsteckschild, 4er-Set

sign, set of 4
étiquette enfichables, séries de 4
rótulo insertable, juego de 4
tarthetta inseribile, set da 4

Ohne beschriftete Schilder. Für alle Brillen mit kleinen Ausschnitten Ø 11,5 cm. Nicht einzeln lieferbar! /

Without signs. For all insert holders with small cut out Ø 4 1/2 in. Only available in 4 pc-set!

Cromargan® / stainless 18/10

Ø	Ø
cm	in.
12,5	5

06.2447.6040



Etagère, 2-tlg.

etagere, 2 parts
 étagère, 2 anneaux
 frutero articulado, de 2 brazos
 etagere, 2 anelli

zum Aufschauben auf die Reling, passend für Glasschalen Ø 20 cm, Porzellankugel XL, Tablett 06.3014.6041 und Tortenplatte 06.3014.6042 /
 to attach to the rail, fitting for glass bowl Ø 8 in., porcelain bowl XL, serving tray 06.3014.6041 and cake plate 06.3014.6042

Cromargan® / stainless 18/10

Höhe	height
cm	in.
28,4	11 ¹ / ₄

06.2441.6040



Glasschale, 20 cm

glass bowl, 20 cm
 coupe verre glasskin, 20 cm
 depósitos de cristal, 20 cm
 interno in vetro, 20 cm

passend in Etagère 06.3010.6040, 06.3011.6040, 06.4394.6040, 06.2441.6040 combiNation buffet /
 fitting in etagere 06.3010.6040, 06.3011.6040, 06.4394.6040, 06.2441.6040 combiNation buffet

stapelbar /
 stackable

Höhe	height	Ø	Ø
cm	in.	cm	in.
8,5	3 ¹ / ₄	20	8

19.9999.8642



Deckel zu Glasschale

lid for glass bowl
 couvercle pour coupe en verre
 tapa para depósitos de cristal
 coperchio per scodella di vetro

passend auf Glasschale Ø 20 cm 19.9999.8642, einfach zu öffnen durch Drehen /
 fitting on glass bowl Ø 8 in. 19.9999.8642, easy to open by turning

Cromargan® / stainless 18/10

Ø	Ø
cm	in.
20	8

06.3010.6042



Tortenplatte

cake plate
 plat à tarte
 plato tarta
 piatto da torta

passend in Etagère 06.3010.6040, 06.3011.6040, 06.2441.6040 combiNation buffet /
 fitting in etagere 06.3010.6040, 06.3011.6040, 06.2441.6040 combiNation buffet

Cromargan® / stainless 18/10

Ø	Ø
cm	in.
32	12 ¹ / ₂

06.3014.6042



Tablett, rund

service tray, round
plateau de service, rond
bandeja, redonda
vassoio, rontondo

passend in Etagère 06.3010.6040, 06.3011.6040, 06.2441.6040
combiNation buffet /
fitting in etagere 06.3010.6040, 06.3011.6040, 06.2441.6040
combiNation buffet

Cromargan® / stainless 18/10

Ø außen	outer Ø	Ø innen	Ø inside
cm	in.	cm	in.
29,5	11½	24,5	9¾

06.3014.6041



Kühlbehälter, mit Kühlpellet

cooler, with cooling element
coupe réfrigérante, avec élément réfrigérante
recipiente, con acumulador de frio
base, con elemento refrigerante

passend in Etagère 06.3010.6040, 06.3011.6040, 06.2441.6040
combiNation buffet zum Kühlen von Tablett 06.3014.6041 und
Tortenplatte 06.3014.6042 /
fitting in etagere 06.3010.6040, 06.3011.6040, 06.2441.6040
combiNation buffet to cool tray 06.3014.6041 and cake plate
06.3014.6042

Cromargan® / stainless 18/10

Ø	Ø
cm	in.
19	7½

06.3014.6044

Ersatzteil / spare part:

Kühlpellet / cooling element 19.9999.5850

Kühlbehälter, ohne Kühlpellet /
cooler, without cooling element 06.3014.6045



Früchtekorb

fruit basket
panier à fruits
frutero
fruttiera

passend in Etagère 06.3010.6040, 06.3011.6040, 06.2441.6040
combiNation buffet nur in Verbindung mit Kühlbehälter 06.3014.6045
(bitte separat bestellen) /
fitting together with cooler 06.3014.6045 (please order separately) in
etagere 06.3010.6040, 06.3011.6040, 06.2441.6040 combiNation buffet

Cromargan® / stainless 18/10

Höhe	height	Ø	Ø
cm	in.	cm	in.
22,5	8¾	26	10¼

06.6521.6040

**Besteckbaum, 3-tlg.**

utensil holder, 3 parts
 étagère à couverts, en 3 parties
 árbol cubertero, de 3 piezas
 portapostate con stuttura ad albero, a 3 ramificazioni

zum Aufstecken **auf** freien **Bolzen** am Anfang oder Ende der Reling.
 Inkl. Einsätze.

Fassungsvermögen je Behälter ca. 50 Besteckteile /
 to put **on** available **adapters** at begin either end of the rail. Inclusive
 inserts. Capacity per insert approx 50 utensils

Cromargan® / stainless 18/10

Höhe cm	height in.	Ø Ring cm	Ø ring in.	
53	20 ³ / ₄	11,5	4 ¹ / ₂	06.2448.6040

Ersatzteil / spare part:

Dressingbehälter / dressing insert 06.1762.6043

**Hygieneschutz**

hygienic cover
 plateau pléxiglas
 protector higiéniico
 copertura

bestehend aus 2 Seitenteilen und 1 Schutzplatte, demontierbar /
 consisting of 2 side bars and 1 protective cover, can be dismantled

höhenverstellbar /
 height adjustable

Cromargan®, Kunststoff transparent /
 stainless 18/10, transparent plastic cover

Breite cm	width in.	Höhe cm	height in.	Tiefe cm	outer Ø in.	
110*	43 ¹ / ₄ *	49 - 69	19 ¹ / ₄ - 27 ¹ / ₄	46	18	06.2444.6040
76**	30**	49 - 69	19 ¹ / ₄ - 27 ¹ / ₄	46	18	06.2445.6040

* für Reling L mit 3 Rahmen / for rail L with 3 frames

** für Reling M mit 2 Rahmen / for rail M with 2 frames

Schreibtafel S

blackboard S
 tableau S
 pizarra S
 lavagna S

beidseitig mit Kreide oder Tafelstiften (Illumigraphen) beschreibbar,
 zum Aufstecken auf Reling /
 double sided, to be written on with chalk or graphic pens, to attach to
 the rail

Kunststoff / plastic

Größe cm	size in.	
32,8 x 30	13 x 11 ³ / ₄	06.2427.9990





Plexiglashülle S

plexi glass frame S
 plateau pléxiglas S
 marco de metacrilato S
 porta immagini in plexi S

an 3 Seiten offen zum Einlegen von Bildmotiven, zum Aufstecken auf Relling /

open 3 sides to insert graphics, to attach to the rail

Kunststoff / plastic

Größe	size
cm	in.
32,5 x 30	12 ³ / ₄ x 11 ³ / ₄

06.2428.9990



Bebildungs-Satz, für Plexiglashülle S

set of illustrations, for plexi glass frame S
 série d'illustrations, pour gaine pléxiglas S
 juego de ilustración, para funda de plexiglás S
 serie di illustrazioni, per le coperture in plexiglas S

bestehend aus:

42 hochwertigen Drucken von gängigen, farbigen Food-Motiven
 15 unbedruckten Blättern (verwendbar zum Selbstbeschriften oder als
 Passepartout für Eigenkreationen / Ausdrücke) /

consisting of:

42 high-quality prints of 21 everyday food motifs in colour
 15 unprinted sheets (for you to write on or as passe-partout for your
 own creations / print-outs)

Satz komplett / set complete

60.3062.9990

Weitere Bildmotive finden Sie auf www.ccvision.de /

As a source for more picture motifs, we recommend the home page
www.ccvision.de

■ **combiNation buffet**

»Müsli / Quark / Obst«

Fromage Frais, Fruit

Metall-Teile aus Cromargan®, insgesamt 85 cm lang, Tischtiefe mindestens 75 cm

Metal parts from stainless 18/10, total length 33 1/2 in.,

Minimum depth of the table 29 1/4 in.

Bestehend aus / comprising:



Grundreling M / basic rail M 06 2411 6040

Etagère / etagere 06 2441 6040

2 x Glasschale / glass bowl
zu Etagère Ø 20 cm / Ø 8 in. 19 9999 8642

2 x Plexihülle S / plexi glass frame für Bilder / for pictures 06 2428 9990

2 x Rahmen / frame GN 1/1 mittel /medium 06 2420 6040

Tablett / serving tray 18/10 GN 1/1 06 7660 6040

Eiswanne / ice tray
(o. Abb. / without picture) 06 2426 9990

Brille / insert holder GN 1/1
2 Ausschnitte / 2 cut outs 06 2436 6040

2 x Glasschale / glass bowl Ø 23 cm / Ø 9 in. 19 9999 8673

■ **combiNation buffet**

»Vorspeisen / Kalte Speisen«

Starters, Cold Dishes

Metall-Teile aus Cromargan®, insgesamt 120 cm lang,

Tischtiefe mindestens 75 cm

Metal parts from stainless 18/10, total length 47 1/4 in.,

Minimum depth of the table 29 1/4 in.

Bestehend aus / consisting of:



Grundreling L / basic rail L 06 2410 6040

2 x Plexihülle S / plexi glass frame
für Bilder / for pictures 06 2428 9990

Schreibtafel / blackboard 06 2427 9990

3 x Rahmen / frame GN 1/1
mittel / medium 06 2420 6040

Eiswanne / ice tray plastic
(o. Abb. / without picture) 06 2426 9990

Kunststoffplatte / platter acrylic GN 1/1 06 2432 9990

Corianplatte / platter Corian GN 1/1 06 2431 9990

Tablett / serving tray 18/10 GN 1/1 06 7660 6040

■ **combiNation buffet**

»Salat / salad«

Metall-Teile aus Cromargan®, insgesamt 120 cm lang,
Tischtiefe mindestens 75 cm
Metal parts from stainless 18/10, total length 47 1/4 in.,
Minimum depth of the table 29 1/4 in.
Bestehend aus / consisting of:



Grundreling L / basic rail L		06 2410 6040
Schreibttafel / blackboard		06 2427 9990
2 x Plexihülle S / plexi glass frame für Bilder / for pictures		06 2428 9990
2 x Rahmen / frame	GN 1/1 hoch / high	06 2421 6040
Brille / insert holder 8 Ausschnitte / 8 cut outs	GN 1/1	06 2437 6040
2 x Porzellankugel klein / porcelain bowl small	0,5 l / 17,5 oz.	60 3058 9990
2 x Beilagenschale / bowl for ingredients		06 0315 6040
4 x Dressingtopf / dressing insert		06 1762 6043
Rahmen / frame	GN 1/2 hoch / high	06 2418 6040
Rahmen / frame	GN 1/2 mittel / medium	06 2417 6040
2 x Brille / insert holder 1 Ausschnitt / 1 cut out	GN 1/2	06 2434 6040
2 x Glasschale / glass bowl	23 cm / 9 in.	19 9999 8673
Porzellaneinsatz / porcelain insert	GN 1/1-20	60 3053 9990

■ **combiNation buffet**

»Chafing Dish«

Metall-Teile aus Cromargan®, insgesamt 120 cm lang,
Tischtiefe mindestens 75 cm
Metal parts from stainless 18/10, total length 47 1/4 in.,
Minimum depth of the table 29 1/4 in.
Bestehend aus / consisting of:



Grundreling L / basic rail L		06 2410 6040
Schreibttafel / blackboard		06 2427 9990
2 x Plexihülle S / plexi glass frame für Bilder / for pictures		06 2428 9990
3 x Chafing Dish	GN 1/1	
ohne Einsatz, ohne Heizelement without insert, without heating element		06 2423 6040
3 x Heizelement / heating element 230 V / 700 Watt		06 3286 6044
2 x Porzellan Einsatz / porcelain insert	GN 1/2 - 65	60 3045 9990
2 x Porzellaneinsatz / porcelain insert	GN 1/1 - 65	60 3044 9990
3 x Porzellan Einsatz / porcelain insert	GN 1/3-20	60 3055 9990

■ **Welche Länge hat Ihr künftiges Buffet?**
– Die Maße.
 Jede Grundreling ist mit jeder Erweiterungsreling kombinierbar. Bei jedem Anbau an eine Grundreling **A** oder **B** muss also die Länge der zusätzlichen Erweiterungsrelsings **C** oder **D** dazu addiert werden.
Tischtiefe mindestens 70 cm!

■ **How long is your future buffet?**
– Measurements.
 Each basic rail can be combined with each extension rail. For each attachment to a basic rail **A** or **B**, therefore, the length of the additional extension rails **C** or **D** should be added.
Depth of table minimum 70 cm / 27 1/2 in!

■ **Quelle est la largeur de votre futur buffet?**
– Les dimensions.
 chaque support 2 barres de base peut être combiné avec chaque support 2 barres supplémentaire. Il faut donc additionner la largeur des supports supplémentaires **A** ou **B** pour chaque support supplémentaire ajouté à un support de base **C** ou **D**.
Profondeur de table minimum 70 cm!

■ **¿Qué ancho tiene su futuro mostrador?**
– Las medidas.
 Cada barandilla base se puede combinar con cada barandilla de ampliación. Por lo tanto, en cada montaje a una barandilla base **A** o **B** se tiene que sumar la cantidad multiplicada por el ancho de las barandillas de ampliación **C** o **D** adicionales.
La profundidad de la mesa por lo menos 70 cm!

■ **Quale larghezza avrà il vostro futuro buffet?**
– Le quote.
 Ogni reling base può essere combinato con ogni reling di estensione. Per ogni montaggio supplementare su un reling base **A** o **B** si deve addizionare il numero x larghezza dei reling di estensione supplementari **C** o **D**.
Profondità del tavolo minimum 70 cm!

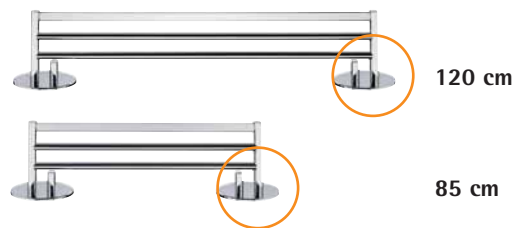

Maße und Beispiele / examples and measures:

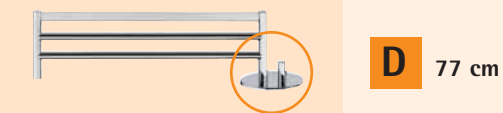
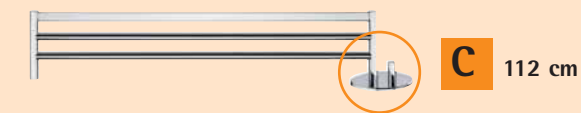
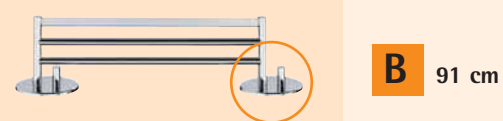
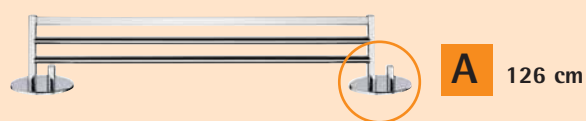

$$\begin{aligned} &A + C \\ &= 126 + 112 \\ &= \underline{238 \text{ cm}} \end{aligned}$$



$$\begin{aligned} &A + (2 \times D) \\ &= 126 + (2 \times 77) \\ &= \underline{280 \text{ cm}} \end{aligned}$$



$$\begin{aligned} &B + (2 \times C) \\ &= 91 + (2 \times 112) \\ &= \underline{315 \text{ cm}} \end{aligned}$$

A Grundreling L
 Basic rail L
 Support 3 barres de base L
 Soporte principal L
 Unità base L

B Grundreling M
 Basic rail M
 Support 3 barres de base M
 Soporte principal M
 Unità base M

C Erweiterungsreling L
 Extension rail L
 Support 3 barres supplémentaire L
 Soporte adicional L
 Estensione L

D Erweiterungsreling M
 Extension rail M
 Support 3 barres supplémentaire M
 Soporte adicional M
 Estensione M

Das Prinzip
CHANGE
principle of
CHANGE

Variabel und stilsicher
Variable, with a clear
sense of style

Produktvarianten
range of products



CEREALIENDISPENSER
CEREAL DISPENSER



SAFT- /MILCHDISPENSER
JUICE- /MILK DISPENSER



CHAFING DISHES



COFFEE URNS

Designvarianten
range of design



BASIC



MANHATTAN



PALAST

Produktvorteile

Individuelle Lösungen sind die Stärke der WMF Collection CHANGE. Variabel und stilvoller harmonisiert alles mit jeder Einrichtung.

Starke Typen

Chafing Dishes, Dispenser für Saft, Milch und Cerealien oder Coffee Urns, es passt alles zusammen.

Traditionelle Qualität

Qualität und Funktionalität aus Tradition stehen auch hier ganz oben.

Material und Verarbeitung

Hochwertiges Cromargan® ist je nach Modell mattiert oder poliert und teilweise um vergoldete Zierelemente ergänzt. Die Cerealien-Röhre besteht aus transparentem PMMA, alle anderen Kunststoffteile aus schwarzem POM. Also absolut geruchsneutral und lebensmittelgeeignet.

Advantages of the products

Custom solutions are the WMF CHANGE collection's strong point. Variable and stylish, it harmonises with any decor.

Perfect match

Everything fits together: Chafing dishes, coffee urns, juice-, milk- and cereal dispensers.

Traditional quality

Quality and functionality born in tradition is our top priority.

Material and finish

High-grade Cromargan® / stainless 18/10 is either satin finished or polished, according to the model. Some models are decorated with gold plate. The cereal chutes are made from clear PMMA. All other plastic parts are black POM. They are totally odourless and food safe.



Auf Anfrage auch in Sonderausführung

Special design on request

Chafing Dish HOT & FRESH

**Frischer,
flexibler,
funktioneller
... induktiv!**

more freshness,
more flexibility,
more function
... inductive!

Außergewöhnliches Design, flexibel und mit hoher Funktionalität. WMF HOT & FRESH Chafing Dishes verfügen über viele Produktvorteile: Hitzebeständige Griffe, gastro-nomiegerechtes Material sowie umfangreiches Zubehör. Und die Produkte passen perfekt in die WMF CHANGE-Kollektion.

Outstanding design, flexibility and a high level of functionality, WMF HOT & FRESH chafing dishes also have other product benefits, including heat-resistant handles, catering-grade material and an extensive range of accessories. And they still match your current style as the products coordinate perfectly with the WMF CHANGE Collection!



CHANGE,
rund / round



CHANGE,
GN 2/3



MANHATTAN



PALAST



BASIC

Steht über allem!

So bleiben Ihre Speisen überall heiß und appetitlich. WMF Chafing Dishes HOT & FRESH sind induktionsfähige Warmhaltegeräte und erfüllen Ihren Job auch auf den gängigen Wärmequellen wie Heizplatten und Brennstoff-dosen.

Universal

So your food remains hot and appetising throughout. WMF HOT & FRESH chafing dishes not only meet the demand for chafing dishes suitable for induction systems but also perform well with standard heat sources; hotplates and sterno systems.



Direkt auf den
Induktionsherd
inductive
cooking



Gestell Variante
alternativ zu CHANGE
Alternative frame to
buffet stand CHANGE





Was erwarten Sie von Ihren Chafing Dishes? Ansprechendes Design? Top-Qualität? Perfektes Handling?

Die Serie WMF HOT & FRESH bietet Ihnen deutlich mehr. Sie begeistert durch den verkapselten Transtherm®-Boden, den transparenten Glasdeckel und ein intelligentes Kondenswasser-rücklaufsystem. Ganz gleich, ob GN 2/3 oder rund.

What do you expect from your chafing dishes? An attractive design? Top quality? Perfect handling?

The WMF HOT & FRESH range offers you perceptibly more. The encapsulated Transtherm® base, the transparent glass lid and an intelligent condensation recirculating system will convince you; whether in GN 2/3 or round.

**Ganz soft.
Ganz oft.**

Qualität made in Germany: Die Deckellösung macht das Öffnen und Schließen des Chafing Dish zum Vergnügen.

Jeder WMF HOT & FRESH Chafing Dish ist mit einem transparenten Glasdeckel ausgestattet, so haben Sie immer einen Blick auf die Speisen. Der Deckel lässt sich spielend leicht öffnen und in verschiedenen Stufen einrasten. Noch einfacher ist das Schließen: Der Lauf des Deckels wird optimal gedämpft. Dafür sorgt die in Deutschland entwickelte, besonders langlebige Bremse.

**Smooth operation.
Over and over again.**

German-made quality: the lid solution makes opening and closing the chafing dish a pleasure.

Every WMF HOT & FRESH chafing dish is equipped with a transparent glass lid. That provides a clear view of the food, even when closed. It's so easy to open, and it engages at various opening angles. Closing it is even easier: the lid movement is controlled by a long-life brake mechanism developed in Germany.



Chafing Dish HOT & FRESH



Zubehör Accessories

Besteckablage / Tray/cutlery holder, Cromargan®

06.3539.6040

Schale für Besteckablage / Porcelain bowl, Porzellan, weiß / porcelain, white
60.3540.9990

Chafing Dish Besteck / cutlery, Cromargan®, Länge 32,5 cm, length in. 12 3/4

Löffel / spoon 12.8381.6041

Gabel / fork 12.8381.6042

Chafing Dish Besteck / cutlery, Cromargan®, Länge 26 cm, length in. 10 1/4

Löffel / spoon 12.8386.6041

Gabel / fork 12.8386.6042

Zange / tongs, Cromargan®, Länge 31 cm, length 31 cm/in.12 1/4

12.8341.6040

Porzellan-Einsatz, rund / Porcelain insert round,

Tiefe 70 mm, ø 33,5 cm / depth 70 mm / 2 3/4 in. Ø 33,5 cm / 13 1/4 in.
60.3072.9990

Porzellan-Einsatz, rund geteilt / Porcelain insert round, divided

Tiefe 70 mm, ø 33,5 cm / depth 70 mm / 2 3/4 in. Ø 33,5 cm / 13 1/4 in.
60.3073.9990

Einsatz Cromargan®, rund, Insert Cromargan®, round

Tiefe 80 mm, depth 80 mm / 3 1/4 in.

06.2083.6034

Tiefe 100 mm, depth 100 mm / 4 in.

06.2083.6033

Brennstoffdosen / solid alcohol

Großpackung 36 Stk., Inhalt 0,2l je Dose, large package 36 pcs. each tin 0,2 l / 7 oz.
60.3002.0690

Brennstoffdosenhalter / burner holder

für alle Gestelle GN 1/1 und rund / for stands GN 1/1 and round
Maße 26 x 20 x 8 cm / 10 1/4 x 8 x 3 1/4 in.

06.3322.6039

Heizelement mit Regler / Heating element, heat adjustable

für alle Gestelle GN 2/3 und rund / for stands GN 2/3 and round
230 V / 700 W, 25 x 20 cm / 9 3/4 x 8 in.

06.3286.6046

Heizelement, selbstregelnd / Heating element

für alle Gestelle GN 2/3 und rund / for stands GN 2/3 and round
140-250 V / 220 W, 25 x 20 cm / 9 3/4 x 8 in.

55.0095.6044

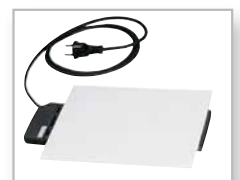

Suppenmarmite Cromargan®, rund / Soup tureen Cromargan®, round, ø 34 cm/13½ in.

9,0 Ltr. / 315 oz.	Topf mit Aufliegedeckel / pot with normal lid	06.3297.6040
	Einsatzring / ring	06.2087.6044
4,5 Ltr. / 157,5 oz.	Topf für Aufliegedeckel / pot for normal lid	06.2007.6041
	Aufliegedeckel / lid normal for normal lid	06.2098.6042
	Einsatzring / ring	55.0068.6040
4,5 Ltr. / 157,5 oz.	Topf für Scharnierdeckel / pot for hinged lid	06.2007.9991
	Scharnierdeckel / hinged lid	06.2007.9992
	Einsatzring / ring	55.0068.6040

Suppenmarmite Cromargan®, GN 2/3 /Soup tureen Cromargan®, GN 2/3, 36x33 cm/14¼x13 in.

9,0 Ltr. / 315 oz.	Topf mit Aufliegedeckel / pot with normal lid	06.3297.6040
	Einsatzring / ring	06.2094.6044
4,5 Ltr. / 157,5 oz.	Topf für Aufliegedeckel / pot for normal lid	06.2007.6041
	Aufliegedeckel / lid normal for normal lid	06.2098.6042
	Einsatzring / ring	06.3301.6044
4,5 Ltr. / 157,5 oz.	Topf für Scharnierdeckel / pot for hinged lid	06.2007.9991
	Scharnierdeckel / hinged lid	06.2007.9992
	Einsatzring / ring	06.3301.6044

**Porzellan-Einsatz / Porcelain insert
Chafing Dish GN**

GN 1/3	Tiefe 20 mm	depth 20 mm / ¾ in.	60.3055.9990
GN 1/3	Tiefe 65 mm	depth 65 mm / 2½ in.	60.3047.9990
GN 2/3	Tiefe 20 mm	depth 20 mm / ¾ in.	60.3056.9990
GN 2/3	Tiefe 65 mm	depth 65 mm / 2½ in.	60.3046.9990

**Edelstahl-Einsatz / Insert Cromargan®
Chafing Dish GN**

GN 1/3	Tiefe 65 mm	depth 65 mm / 2½ in.	19.9955.0577
GN 1/3	Tiefe 100 mm	depth 100 mm / 4 in.	19.9955.0578
GN 2/3	Tiefe 65 mm	depth 65 mm / 2½ in.	19.9955.0585
GN 2/3	Tiefe 100 mm	depth 100 mm / 4 in.	19.9955.0586





**Chafing Dish, „Basic“, rund
HOT & FRESH**

Chafing Dish, „Basic“, round
Chafing Dish, „Basic“, rond
Chafing Dish, „Basic“, redondo
Chafing Dish, „Basic“, rotondo

passend für Einsätze bis Tiefe 10 cm, induktionsgeeignet, alternativ mit Heizplatte und Brennstoff beheizbar, Glasdeckel mit Bremse abnehmbar, Bügelgriff / fitting for inserts up to depth 10 cm / 4in., inductive, electrically and sterno heating possible, glass lid with brake removable, bow handle

Cromargan®, Glas / stainless 18/10, glass

Höhe	height	Ø	Ø	
cm	in.	cm	in.	
19	7½	39	15¼	55.0001.6040



**Chafing Dish, „Manhattan“, rund
HOT & FRESH**

Chafing Dish, „Manhattan“, round
Chafing Dish, „Manhattan“, rond
Chafing Dish, „Manhattan“, redondo
Chafing Dish, „Manhattan“, rotondo

passend für Einsätze bis Tiefe 10 cm, induktionsgeeignet, alternativ mit Heizplatte und Brennstoff beheizbar, Glasdeckel mit Bremse abnehmbar, Griff 4-Kantprofil (mattiert) / fitting for inserts up to depth 10 cm / 4in., inductive, electrically and sterno heating possible, glass lid with brake removable, handle profile 4-cornered (satin finished)

Cromargan®, Glas / stainless 18/10, glass

Höhe	height	Ø	Ø	
cm	in.	cm	in.	
19	7½	39	15¼	55.0020.6040



**Chafing Dish, „Palast“, rund
HOT & FRESH**

Chafing Dish, „Palast“, round
Chafing Dish, „Palast“, rond
Chafing Dish, „Palast“, redondo
Chafing Dish, „Palast“, rotondo

passend für Einsätze bis Tiefe 10 cm, induktionsgeeignet, alternativ mit Heizplatte und Brennstoff beheizbar, Glasdeckel mit Bremse abnehmbar, Griff vergoldet / fitting for inserts up to depth 10 cm / 4 in., inductive, electrically and sterno heating possible, glass lid with brake removable, handle gold plated

Cromargan®, Glas / stainless 18/10, glass

Höhe	height	Ø	Ø	
cm	in.	cm	in.	
19	7½	39	15¼	55.0026.6210



Chafing Dish, „Basic“, GN 2/3

HOT & FRESH

Chafing Dish, „Basic“, GN 2/3

Chafing Dish, „Basic“, GN 2/3

Chafing Dish, „Basic“, GN 2/3

Chafing Dish, „Basic“, GN 2/3

passend für Einsätze bis Tiefe 10 cm, induktionsgeeignet, alternativ mit Heizplatte und Brennstoff beheizbar, Glasdeckel mit Bremse abnehmbar, Bügelgriff /

fitting for inserts up to depth 10 cm / 4 in., inductive, electrically and sterno heating possible, glass lid with brake removable, bow handle

Cromargan®, Glas / stainless 18/10, glass

Größe	size
cm	in.
37 x 45 x 19	14 ¹ / ₂ x 17 ³ / ₄ x 7 ¹ / ₂

55.0002.6040



Chafing Dish, „Manhattan“, GN 2/3

HOT & FRESH

Chafing Dish, „Manhattan“, GN 2/3

Chafing Dish, „Manhattan“, GN 2/3

Chafing Dish, „Manhattan“, GN 2/3

Chafing Dish, „Manhattan“, GN 2/3

passend für Einsätze bis Tiefe 10 cm, induktionsgeeignet, alternativ mit Heizplatte und Brennstoff beheizbar, Glasdeckel mit Bremse abnehmbar, Griff 4-Kantprofil (mattiert) /

fitting for inserts up to depth 10 cm / 4 in., inductive, electrically and sterno heating possible, glass lid with brake removable, handle profile 4-cornered (satin finished)

Cromargan®, Glas / stainless 18/10, glass

Größe	size
cm	in.
37 x 45 x 19	14 ¹ / ₂ x 17 ³ / ₄ x 7 ¹ / ₂

55.0021.6040



Chafing Dish, „Palast“, GN 2/3

HOT & FRESH

Chafing Dish, „Palast“, GN 2/3

Chafing Dish, „Palast“, GN 2/3

Chafing Dish, „Palast“, GN 2/3

Chafing Dish, „Palast“, GN 2/3

passend für Einsätze bis Tiefe 10 cm, induktionsgeeignet, alternativ mit Heizplatte und Brennstoff beheizbar, Glasdeckel mit Bremse abnehmbar, Griff vergoldet /

fitting for inserts up to depth 10 cm / 4 in., inductive, electrically and sterno heating possible, glass lid with brake removable, handle gold plated

Cromargan®, Glas / stainless 18/10, glass

Größe	size
cm	in.
37 x 45 x 19	14 ¹ / ₂ x 17 ³ / ₄ x 7 ¹ / ₂

55.0027.6210



**Buffetgestell, „Basic“, rund
HOT & FRESH**

frame, „Basic“, round
bati, „Basic“, rond
soporte buffet, „Basic“, redondo
telaio, „Basic“, rotondo

für Heizplatte und Brennstoff, Füße Rundprofil /
for electrically and sterno heating, feet profile round

Cromargan® / stainless 18/10

Höhe	height	Ø	Ø
cm	in.	cm	in.
24	9½	47	18½

55.0007.6040



**Buffetgestell, „Manhattan“, rund
HOT & FRESH**

frame, „Manhattan“, round
bati, „Manhattan“, rond
soporte buffet, „Manhattan“, redondo
telaio, „Manhattan“, rotondo

für Heizplatte und Brennstoff, Füße 4-Kantprofil (mattiert) /
for electrically and sterno heating, feet profile 4-cornered (satin finished)

Cromargan® / stainless 18/10

Höhe	height	Ø	Ø
cm	in.	cm	in.
24	9½	47	18½

55.0008.6040



**Buffetgestell, „Palast“, rund
HOT & FRESH**

frame, „Palast“, round
bati, „Palast“, rond
soporte buffet, „Palast“, redondo
telaio, „Palast“, rotondo

für Heizplatte und Brennstoff, Füße vergoldet /
for electrically and sterno heating, feet gold plated

Cromargan® / stainless 18/10

Höhe	height	Ø	Ø
cm	in.	cm	in.
24	9½	47	18½

55.0011.6210



Buffetgestell, „Basic“, GN 2/3

HOT & FRESH

frame, „Basic“, GN 2/3

bati, „Basic“, GN 2/3

soporte buffet, „Basic“, GN 2/3

telaio, „Basic“, GN 2/3

für Heizplatte und Brennstoff, Füße Rundprofil /
for electrically and sterno heating, feet profile round

Cromargan® / stainless 18/10

Größe	size
cm	in.
44 x 40 x 24	17 1/4 x 15 3/4 x 9 1/2

55.0012.6040



Buffetgestell, „Manhattan“, GN 2/3

HOT & FRESH

frame, „Manhattan“, GN 2/3

bati, „Manhattan“, GN 2/3

soporte buffet, „Manhattan“, GN 2/3

telaio, „Manhattan“, GN 2/3

für Heizplatte und Brennstoff, Füße 4-Kantprofil (mattiert) /
for electrically and sterno heating, feet profile 4-cornered (satin finished)

Cromargan® / stainless 18/10

Größe	size
cm	in.
44 x 40 x 24	17 1/4 x 15 3/4 x 9 1/2

55.0013.6040



Buffetgestell, „Palast“, GN 2/3

HOT & FRESH

frame, „Palast“, GN 2/3

bati, „Palast“, GN 2/3

soporte buffet, „Palast“, GN 2/3

telaio, „Palast“, GN 2/3

für Heizplatte und Brennstoff, Füße vergoldet /
for electrically and sterno heating, feet gold plated

Cromargan® / stainless 18/10

Größe	size
cm	in.
44 x 40 x 24	17 1/4 x 15 3/4 x 9 1/2

55.0016.6210



**Buffetgestell, rund
HOT & FRESH**

frame, round
bati, rond
soporte buffet, redondo
telaio, rotondo

für Heizplatte und Brennstoff, passend zu allen runden Chafing Dishes
HOT & FRESH /

for electrically and sterno heating, fitting for all round chafing dishes
HOT & FRESH

Cromargan® / stainless 18/10

Höhe	height	Ø	Ø
cm	in.	cm	in.
17	6 ³ / ₄	39	15 ¹ / ₄

55.0005.6040



**Buffetgestell, GN ²/₃
HOT & FRESH**

frame, GN ²/₃
bati, GN ²/₃
soporte buffet, GN ²/₃
telaio, GN ²/₃

für Heizplatte und Brennstoff, passend zu allen Chafing Dishes GN ²/₃
HOT & FRESH /

for electrically and sterno heating, fitting for all chafing dishes GN ²/₃
HOT & FRESH

Cromargan® / stainless 18/10

Größe	size
cm	in.
37 x 40 x 17	14 ¹ / ₂ x 15 ³ / ₄ x 6 ³ / ₄

55.0006.6040

Chafing Dish CHANGE chafing dish CHANGE

Immer eine Hand frei
keeping one hand free

Produktvarianten
range of products



CHAFING DISHES GN 1/1

CHAFING DISHES
rund / round



einfach bedienbar

Ob im GN 1/1-Format oder rund, die Chafing Dishes der Kollektion »CHANGE« haben eines gemeinsam: Ein leicht und fast geräuschlos mit einer Hand zu öffnender Rolltop-Deckel. Das wird jeder schätzen, der einmal versucht hat, mit der einen Hand den Deckel zu halten, in der anderen den Teller – und dann überlegt, wie er sich jetzt bedienen soll?

simply to handle

Both the GN 1/1 size and the round chafing dishes in the »CHANGE« line have one thing in common: a roll-top lid which runs almost silently and is easy to open with just one hand. That will be appreciated by anyone who has ever tried to keep the lid open with one hand while holding a plate in the other... and then wondered how to reach the food!



Produktvorteile

Auch bei dem runden Chafing Dish ist durch die **spezielle Kabelführung** gewährleistet, dass der Deckel beim Einsatz eines elektrischen Heizteiles problemlos geöffnet werden kann.



Die **Griffe sind hitzeisoliert** und somit auch im Betrieb ohne den Einsatz von Tüchern und sonstigen Hilfsmitteln zu öffnen.



Der im Deckelrand integrierte **Kondenswasserrücklauf** verhindert das Tropfen und dadurch unschöne Kondenswasser-Pfützen auf dem Tisch.



Alle Modelle (außer Manhattan) sind platzsparend **stapelbar**.



Der Deckel des GN 1/1 ist mit 2 hochwertigen **Scheibenbremsen** ausgestattet, die einfach zu justieren und einzustellen sind.



Der Deckel ist komplett versenkbar und schwingt exzentrisch um den Brennstoffdoshalter oder um die Heizplatte. Die Speisen sind komplett zugänglich und die Belüftung der Flamme ist stets gewährleistet. Der Deckel der runden Chafing Dishes kann in drei Positionen, der des GN 1/1-Modelles stufenlos arretiert werden.



Advantages of the products

The round chafing dish now includes a **special flex clip**, allowing the lid to be opened freely when using electric heating.

The **handles are insulated** to allow the lids to be opened for serving without using a cloth or other holder.

The **condensation return** built into the edge of the lid prevents drips and unsightly puddles on the tabletop.

All the models (except Manhattan) are **stackable** to save space.

The lid of the GN 1/1 is fitted with two **high-class disk brakes**. They can be setting up and adjusted simply.

The lid is fully roll-top and is offset to the burner holder or hotplate when opened. When the lid is fully opened, the food is easily accessible while still ensuring adequate ventilation for the flame. The round chafing dish lid can be opened to three different positions and the GN 1/1 model lid is infinitely adjustable.



Chafing Dish, „Basic“

CHANGE

Chafing Dish, „Basic“
 Chafing Dish, „Basic“
 Chafing Dish, „Basic“
 Chafing Dish, „Basic“

passend für Einsätze bis Tiefe 10 cm /
 fitting for inserts up to depth 4 in.

GN 1/1, Rolltopdeckel, elektrisch und Brennstoff beheizbar, Bremse nachstellbar, Deckel versenkbar /
 GN 1/1, full rolltop cover, electrically and sterno heated, adjustable brake, cover immersible

Cromargan®, Füße Rundprofil, Bügelgriffe /
 stainless 18/10, feet profil round, with bow handles
 ohne Einsätze / w/o inserts

Höhe cm	height in.	Größe mit Griffen cm	size with handles in.
45,6	18	74 x 38	28 1/4 x 15

06.3333.6040

Zubehör / accessory:

Heizelement 230 V / 600 W / heating element 230 V / 600 W	55.0097.6044
Heizelement 120 V / 600 W / heating element 120 V / 600 W	55.0097.9990
Heizelement 230 V / 700 W mit Regler / heating element 230 V / 700 W heat adjustable	06.3286.6046
Brennstoffdosenhalter / burner holder	06.3322.6039



Chafing Dish, „Metropolitan“

CHANGE

Chafing Dish, „Metropolitan“
 Chafing Dish, „Metropolitan“
 Chafing Dish, „Metropolitan“
 Chafing Dish, „Metropolitan“

passend für Einsätze bis Tiefe 10 cm /
 fitting for inserts up to depth 4 in.

GN 1/1, Rolltopdeckel, elektrisch und Brennstoff beheizbar, Bremse nachstellbar, Deckel versenkbar /
 GN 1/1, full rolltop cover, electrically and sterno heated, adjustable brake, cover immersible

Cromargan®, Füße Rundprofil, Kugelgriffe /
 stainless 18/10, feet profil round, with knob handles
 ohne Einsätze / w/o inserts

Höhe cm	height in.	Größe mit Griffen cm	size with handles in.
45,6	18	74 x 38	28 1/4 x 15

06.3330.6040

Zubehör / accessory:

Heizelement 230 V / 600 W / heating element 230 V / 600 W	55.0097.6044
Heizelement 120 V / 600 W / heating element 120 V / 600 W	55.0097.9990
Heizelement 230 V / 700 W mit Regler / heating element 230 V / 700 W heat adjustable	06.3286.6046
Brennstoffdosenhalter / burner holder	06.3322.6039

Bitte Heizelement und Brennstoffdosenhalter separat bestellen. Einzelteile (Seite 188) /
 Please order heating elements and burner holder separately. Spare parts (page 188)



Chafing Dish, „Metropolitan“, rund CHANGE

Chafing Dish, „Metropolitan“, round
Chafing Dish, „Metropolitan“, rond
Chafing Dish, „Metropolitan“, redondo
Chafing Dish, „Metropolitan“, rotondo

passend für Einsätze bis Tiefe 10 cm /
fitting for inserts up to depth 4 in.

rund, Rolltopdeckel, elektrisch und Brennstoff beheizbar, Deckel
versenkbar /
round, full rolltop cover, electrically and sterno heated, cover
immersible

Cromargan®, Füße Rundprofil, Kugelgriff /
stainless 18/10, feet profil round, with knob handle

Höhe	height	∅	∅	
cm	in.	cm	in.	
46	18	43	17	06.3940.6040

Zubehör / accessory:

Heizelement 140-230 V / 270 W / heating element 140-230 V / 270 W	55.0096.6044
Heizelement 100-120 V / 230 W / heating element 100-120 V / 230 W	55.0096.9990
Heizelement 230 V / 550 W mit Regler / heating element 230 V / 550 W heat adjustable	06.2095.6046
Brennstoffdosenhalter / burner holder	06.3940.6039



Chafing Dish, „Manhattan“ CHANGE

Chafing Dish, „Manhattan“
Chafing Dish, „Manhattan“
Chafing Dish, „Manhattan“
Chafing Dish, „Manhattan“

passend für Einsätze bis Tiefe 10 cm /
fitting for inserts up to depth 4 in.

GN 1/1, Rolltopdeckel, elektrisch und Brennstoff beheizbar, Bremse
nachstellbar, Deckel versenkbar /
GN 1/1, full rolltop cover, electrically and sterno heated, adjustable
brake, cover immersible

Cromargan®, teilmattiert, Füße und Griffe im 4-Kantprofil /
stainless 18/10, partly satin finished, handles and feet profil 4-cornered
ohne Einsätze / w/o inserts

Höhe	height	Größe mit Griffen	size with handles	
cm	in.	cm	in.	
45,6	18	74 x 38	28 1/4 x 15	06.3335.6040

Zubehör / accessory:

Heizelement 230 V / 600 W / heating element 230 V / 600 W	55.0097.6044
Heizelement 120 V / 600 W / heating element 120 V / 600 W	55.0097.9990
Heizelement 230 V / 700 W mit Regler / heating element 230 V / 700 W heat adjustable	06.3286.6046
Brennstoffdosenhalter / burner holder	06.3322.6039



**Chafing Dish, „Manhattan“, rund
CHANGE**

Chafing Dish, „Manhattan“, round
Chafing Dish, „Manhattan“, rond
Chafing Dish, „Manhattan“, redondo
Chafing Dish, „Manhattan“, rotondo

passend für Einsätze bis Tiefe 10 cm /
fitting for inserts up to depth 4 in.

rund, Rolltopdeckel, elektrisch und Brennstoff beheizbar, Deckel versenkbar /
round, full rolltop cover, electrically and sterno heated, cover immersible

Cromargan®, teilmattiert, Füße und Griff im 4-Kantprofil /
stainless 18/10, partly satin finished, handle and feet profil 4-cornered

Höhe	height	∅	∅	
cm	in.	cm	in.	
46	18	43	17	06.3945.6040

Zubehör / accessory:

Heizelement 140-230 V / 270 W / heating element 140-230 V / 270 W	55.0096.6044
Heizelement 100-120 V / 230 W / heating element 100-120 V / 230 W	55.0096.9990
Heizelement 230 V / 550 W mit Regler / heating element 230 V / 550 W heat adjustable	06.2095.6046
Brennstoffdosenhalter / burner holder	06.3940.6039



**Chafing Dish, „Palast“
CHANGE**

Chafing Dish, „Palast“
Chafing Dish, „Palast“
Chafing Dish, „Palast“
Chafing Dish, „Palast“

passend für Einsätze bis Tiefe 10 cm /
fitting for inserts up to depth 4 in.

GN 1/1, Rolltopdeckel, elektrisch und Brennstoff beheizbar, Bremse nachstellbar, Deckel versenkbar /
GN 1/1, full rolltop cover, electrically and sterno heated, adjustable brake, cover immersible

Cromargan®, Füße und Griffe vergoldet /
stainless 18/10, feet and handles gold plated
ohne Einsätze / w/o inserts

Höhe	height	Größe mit Griffen	size with handles	
cm	in.	cm	in.	
45,6	18	74 x 38	28 1/4 x 15	06.3331.6210

Zubehör / accessory:

Heizelement 230 V / 600 W / heating element 230 V / 600 W	55.0097.6044
Heizelement 120 V / 600 W / heating element 120 V / 600 W	55.0097.9990
Heizelement 230 V / 700 W mit Regler / heating element 230 V / 700 W heat adjustable	06.3286.6046
Brennstoffdosenhalter / burner holder	06.3322.6039

Bitte Heizelement und Brennstoffdosenhalter separat bestellen. Einzelteile (Seite 188) /
Please order heating elements and burner holder separately. Spare parts (page 188)

Chafing Dish, „Palast“, rund CHANGE

Chafing Dish, „Palast“, round
Chafing Dish, „Palast“, rond
Chafing Dish, „Palast“, redondo
Chafing Dish, „Palast“, rotondo

passend für Einsätze bis Tiefe 10 cm /
fitting for inserts up to depth 4 in.

rund, Rolltopdeckel, elektrisch und Brennstoff beheizbar, Deckel
versenkbar /
round, full rolltop cover, electrically and sterno heated, cover
immersible

Cromargan®, Füße und Griff vergoldet /
stainless 18/10, handle and feet gold plated

Höhe	height	∅	∅
cm	in.	cm	in.
46	18	43	17

06.3941.6210

Zubehör / accessory:

Heizelement 140-230 V / 270 W / heating element 140-230 V / 270 W	55.0096.6044
Heizelement 100-120 V / 230 W / heating element 100-120 V / 230 W	55.0096.9990
Heizelement 230 V / 550 W mit Regler / heating element 230 V / 550 W heat adjustable	06.2095.6046
Brennstoffdosenhalter / burner holder	06.3940.6039



Breite Aufliegerahmen: 14 mm
width supporting frame: 1/2 in.



Chafing Dish, Thekeneinbau STANDARD

Chafing Dish, to be built into counter
Chafing Dish, pour montage en comptoir
Chafing Dish, encastrado
Chafing Dish, emportable

passend zu Einsätze bis Tiefe 10 cm, Heizelement selbstregelnd 230 V /
700 W separat bestellen /
fitting for inserts up to depth 4 in., please order heating element
(electr.) selfcontrolled 230 V / 700 W separately

GN 1/1, Rolltopdeckel, elektrisch beheizbar /
GN 1/1, full rolltop cover, electrically heated

Cromargan® / stainless 18/10
ohne Einsätze / w/o inserts

06.3266.6040

Zubehör / accessory:

Heizelement 230 V / 600 W / heating element 230 V / 600 W	55.0097.6044
Heizelement 120 V / 600 W / heating element 120 V / 600 W	55.0097.9990
Heizelement 230 V / 700 W mit Regler / heating element 230 V / 700 W heat adjustable	06.3286.6046

Ausschnittmaße / cut out size

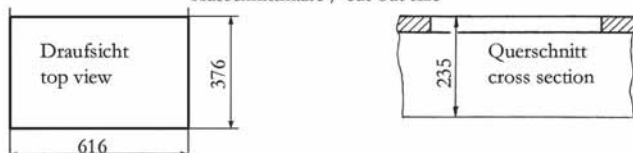



**Portions-Chafing Dish
STANDARD**

Chafing Dish, S
Chafing Dish, S
Chafing Dish, S
Chafing Dish, S

passend für alle handelsüblichen Porzellanteller mit ø 23 cm, beheizbar mit Teelichte (nicht enthalten) / suitable for all porcelain plates ø 9 in., heated by tealights (not included)

rund, Rolltopdeckel, mit 2 Teelichten beheizbar / round, full rolltop cover, heated by 2 tealights

Cromargan® / stainless 18/10
ohne Einsätze / w/o inserts

Höhe cm	height in.	Ø cm	Ø in.
29	11 1/2	26	10 1/4

06.3306.6040



Breite Aufliegerahmen: 14 mm
width supporting frame: 1/2 in.



**Chafing Dish, Thekeneinbau
STANDARD**

Chafing Dish, to be built into counter
Chafing Dish, pour montage en comptoir
Chafing Dish, encastrado
Chafing Dish, emportable

1/2 Rolltop-Deckel, Heizelement selbstregelnd 110 - 230 V / 190 W separat bestellen / round, half rolltop cover, please order heating element (electr.) selfcontrolled 110 - 230 V / 190 W separately

rund, Rolltopdeckel, elektrisch beheizbar / round, full rolltop cover, electrically heated

Cromargan® / stainless 18/10
ohne Heizelement, ohne Einsätze / w/o heating element, w/o inserts

06.3290.6040

Zubehör / accessory:

Heizelement 140-230 V / 270 W / heating element 140-230 V / 270 W	55.0096.6044
Heizelement 100-120 V / 230 W / heating element 100-120 V / 230 W	55.0096.9990
Heizelement 230 V / 550 W mit Regler / heating element 230 V / 550 W heat adjustable	06.2095.6046

Draufsicht / top view

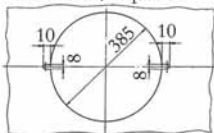

Ausschnittmaße / cut out size

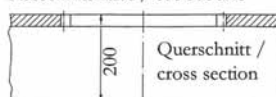

Bitte Heizelement und Brennstoffdosenhalter separat bestellen. Einzelteile (Seite 188) / Please order heating elements and burner holder separately. Spare parts (page 188)



Chafing Dish, mit Domdeckel

ECONOMY

Chafing Dish, conventional standard cover

Chafing Dish, avec couvercle standard

Chafing Dish, tapa estándar

Chafing Dish, con coperchio standard

passend für Einsätze bis Tiefe 10 cm, Deckel zu allen 4 Seiten

hochstellbar /

fitting for inserts up to depth 4 in., lid can be raised on all 4 sides

GN 1/1, stapelbar, Domdeckel, elektrisch und Brennstoff beheizbar /

GN 1/1, stackable, conventional standard cover, electrically and sterno heated

Cromargan® matt / stainless 18/10 satin finished

ohne Einsätze / w/o inserts

Höhe mit Griff height with handle Größe mit Griffen size with handles

cm	in.	cm	in.	
32	12 1/2	62 x 35	24 1/2 x 13 3/4	06.3322.6230

Zubehör / accessory:

Heizelement 230 V / 600 W /

heating element 230 V / 600 W

55.0097.6044

Heizelement 120 V / 600 W /

heating element 120 V / 600 W

55.0097.9990

Heizelement 230 V / 700 W mit Regler /

heating element 230 V / 700 W heat adjustable

06.3286.6046

Brennstoffdosenhalter / burner holder

06.3322.6039

Heizelement 230 V / 1000 W /

heating element 230 V / 1000 W

06.2082.6044

Adapter für Elektroheizteil /

holder for heating element

06.3272.6039



Chafing Dish, mit Klappdeckel

ECONOMY

Chafing Dish, 1/2 rolltop cover

Chafing Dish, avec couvercle rabattable

Chafing Dish, con tapa abatible

Chafing Dish, con coperchio ribaltabile

passend für Einsätze bis Tiefe 10 cm /

fitting for inserts up to depth 4 in.

GN 1/1, Klappdeckel, elektrisch und Brennstoff beheizbar /

GN 1/1, cover, electrically and sterno heated

Cromargan® matt / stainless 18/10 satin finished

ohne Einsätze / w/o inserts

Höhe mit Griff height with handle Größe mit Griffen size with handles

cm	in.	cm	in.	
36	14 1/4	62 x 35	24 1/2 x 13 3/4	06.3324.6230

Zubehör / accessory:

Heizelement 230 V / 600 W /

heating element 230 V / 600 W

55.0097.6044

Heizelement 120 V / 600 W /

heating element 120 V / 600 W

55.0097.9990

Heizelement 230 V / 700 W mit Regler /

heating element 230 V / 700 W heat adjustable

06.3286.6046

Brennstoffdosenhalter / burner holder

06.3322.6039

Heizelement 230 V / 1000 W /

heating element 230 V / 1000 W

06.2082.6044

Adapter für Elektroheizteil /

holder for heating element

06.3272.6039



Ersatzteile für WMF Chafing Dishes
Spare parts for WMF Chafing Dishes

Bezeichnung Designation	Artikel-Nummer Order no.	Cromargan Stainless 18/10	Teilvergoldet partly gold plated	Gestell/Rahmen frame	Deckel cover	Wasserbad- wanne water pan	Einbaurahmen frame	Brennstoffhalter burner holder	Heizelement heating element	Heizelement mit Regler heating element adjustable
Thekeneinbau GN 1/1	06 3266 6040	•			06 3330 6042	06 3319 6231	06 3266 6045		55 0097 6044	06 3286 6046
Thekeneinbau, rund	06 3290 6040	•			06 3283 6042	06 2003 6041	06 3290 6045		55 0096 6044	06 2095 6046
Economy GN 1/1	06 3322 6230	•		06 3322 6235	06 3322 6232	06 3322 6231		06 3322 6039	55 0097 6044	06 3286 6046
Economy GN 1/1	06 3324 6230	•		06 3322 6235	06 3324 6232	06 3322 6231		06 3322 6039	55 0097 6044	06 3286 6046
Metropolitan GN 1/1	06 3330 6040	•		06 3330 6045	06 3330 6042	06 3319 6231		06 3322 6039	55 0097 6044	06 3286 6046
Palast GN 1/1	06 3331 6210		•	06 3331 6215	06 3331 6212	06 3319 6231		06 3322 6039	55 0097 6044	06 3286 6046
Basic GN 1/1	06 3333 6040	•		06 3333 6045	06 3333 6042	06 3319 6231		06 3322 6039	55 0097 6044	06 3286 6046
Manhattan GN 1/1	06 3335 6040	•		06 3335 6045	06 3335 6042	06 3319 6231		06 3322 6039	55 0097 6044	06 3286 6046
Metropolitan rund	06 3940 6040	•		06 3940 6045	06 3940 6042	06 2003 6041		06 3940 6039	55 0096 6044	06 2095 6046
Palast rund	06 3941 6210		•	06 3941 6215	06 3941 6212	06 2003 6041		06 3940 6039	55 0096 6044	06 2095 6046
Manhattan rund	06 3945 6040	•		06 3945 6045	06 3945 6042	06 2003 6041		06 3940 6039	55 0096 6044	06 2095 6046
combiNation Buffet GN 1/1	06 2446 6040	•		06 2423 6045	06 2446 6042	06 3322 6231			55 0097 6044	06 3286 6046
combiNation Buffet GN 1/1	06 2423 6040	•		06 2423 6045	06 2423 6042	06 3322 6231			55 0097 6044	06 3286 6046
combiNation Buffet GN 1/1	06 2442 6040	•		06 2442 6045	06 2423 6042	06 3322 6231		06 2442 6039		06 3286 6046



Suppenmarmite

soup tureen
marmite à potage
recipiente sopa
zuppiera

passend in Chafing Dish GN 1/1 und HOT & FRESH GN 2/3 /
fitting for chafing dish GN 1/1 and HOT & FRESH GN 2/3

Cromargan® / stainless 18/10

Größe cm	size in.	Inhalt Ltr.	cap. oz.
36 x 33	14 1/4 x 13	4,5	157,5

Einsatzring / ring	06.3301.6044
Topf f. Aufliegedeckel / pot f. normal lid	06.2007.6041
Aufliegedeckel / normal lid	06.2098.6042
Topf f. Scharnierdeckel / pot f. hinged lid	06.2007.9991
Scharnierdeckel / hinged lid	06.2007.9992



Suppenmarmite

soup tureen
marmite à potage
recipiente sopa
zuppiera

passend in Chafing Dish GN 1/1 und HOT & FRESH GN 2/3 /
fitting for chafing dish GN 1/1 and HOT & FRESH GN 2/3

Cromargan® / stainless 18/10

Größe cm	size in.	Inhalt Ltr.	cap. oz.
36 x 33	14 1/4 x 13	9	315

Topf mit Deckel / pot with cover	06.3297.6040
Einsatzring / ring	06.2094.6044



Porzellan-Einsatz

porcelain insert
intérieur en porcelaine
interior porcelana
interno in porcellana

passend in Chafing Dish GN 1/1 und 2/3 /
fitting for chafing dish GN 1/1 and 2/3

Cromargan®, Porzellan / stainless 18/10, porcelain

Inhalt Ltr.	cap. oz.	Ø cm	Ø in.
4	140	29	11 1/2

Einsatz / insert	60.3001.0690
Einsatzring / ring	06.2094.6044



Suppenstation, GN 1/1 mit Deckel

soup tureen, GN 1/1 with lid
 marmite à potage, GN 1/1 avec couvercle
 recipiente sopa, GN 1/1 con tapa
 zuppiera, GN 1/1 con coperchio

passend in Chafing Dish GN 1/1 /
 fitting for chafing dish GN 1/1

Größe	size	Inhalt	cap.
cm	in.	Ltr.	oz.
53 x 32,5	20 ³ / ₄ x 12 ³ / ₄	2 x 4,5	2 x 157,5

Ausführung I /quality I

Cromargan® / stainless 18/10
 1 Abdeckplatte, 2 Suppentöpfe mit Scharnierdeckel / 1 insert
 plate and 2 soup tureens with hinged lid
 Komplett / complete

06.2007.9990

Ausführung II /quality II

Cromargan® / stainless 18/10
 1 Abdeckplatte und 2 Suppentöpfe mit Deckel / 1 insert plate
 and 2 soup tureens with lid
 Komplett / complete

06.2007.6040

Ersatzteil / spare part:

Topf f. Scharnierdeckel / pot f. hinged lid 06.2007.9991

Topf f. Aufliedeckel / pot f. normal lid 06.2007.6041

Scharnierdeckel / hinged lid 06.2007.9992

Aufliedeckel / normal lid 06.2098.6042

Brille / insert holder 06.2098.6044



Tranchierbrett, GN 2/3

cutting board, GN 2/3
 planche à découper, GN 2/3
 tabla para trinchar, GN 2/3
 tagliere, GN 2/3

passend in Chafing Dish GN 1/1 /
 fitting for chafing dish GN 1/1

Kunststoff / plastic

Größe	size
cm	in.
35,4 x 32,5 x 2,2	14 x 12 ³ / ₄ x 1

60.3033.0690



Suppenmarmite

soup tureen
 marmite à potage
 sopera para chafing dish
 zuppiera per chafing dish

passend in alle großen runden WMF Chafing Dishes und in den Chafing Dish HOT & FRESH rund. In 2 Versionen bestellbar: Ring + Topf f. Aufliegedeckel + Aufliegedeckel / Ring + Topf für Scharnierdeckel + Scharnierdeckel. / fitting in all big round WMF chafing dishes and in Chafing Dish HOT & FRESH round. To be ordered in 2 versions: ring + pot f. normal lid + cover / ring + pot f. hinged lid + hinged cover.

Cromargan® / stainless 18/10

Inhalt	cap.	∅	∅
Ltr.	oz.	cm	in.
4,5	157,5	34	13 1/2

Ring / ring	55.0068.6040
Topf f. Aufliegedeckel / pot f. normal lid	06.2007.6041
Aufliegedeckel / normal lid	06.2098.6042
Topf f. Scharnierdeckel / pot f. hinged lid	06.2007.9991
Scharnierdeckel / hinged lid	06.2007.9992



Suppenmarmite

soup tureen
 marmite à potage
 sopera para chafing dish
 zuppiera per chafing dish

passend in alle großen runden Chafing Dishes von WMF und den Chafing Dish HOT & FRESH rund / fitting for all big round WMF chafing dishes and in chafing dish HOT & FRESH round

Cromargan® / stainless 18/10

Inhalt	cap.	∅	∅
Ltr.	oz.	cm	in.
9	315	34	13 1/2

Topf mit Deckel / pot with cover	06.3297.6040
Ring / ring	06.2087.6044



Porzellan-Einsatz

porcelain insert
intérieur en porcelaine
interior porcelana
interno in porcellana

passend in alle großen runden Chafing Dishes von WMF /
fitting for all big round WMF chafing dishes

Cromargan®, Porzellan / stainless 18/10, porcelain

Inhalt	cap.	Ø	Ø
Ltr.	oz.	cm	in.
4	140	34	13 1/2

Einsatz / insert

60.3001.0690

Ring / ring

06.2087.6044



Einsatz für Chafing Dish

insert for chafing dish
intérieur pour chafing dish
depósito para chafing dish
inserto piatto chafing dish

passend in alle großen runden Chafing Dishes von WMF /
fitting for all big round WMF chafing dishes

Cromargan® / stainless 18/10

Höhe	height	Inhalt	cap.
cm	in.	Ltr.	oz.
8	3 1/4	5	175
10,5	4 1/4	6,5	227,5

06.2083.6034

06.2083.6033



Porzellan-Einsatz, geteilt

porcelain insert, divided
intérieur en porcelaine, divisé
recipiente de porcelana, dividido
interno in porcellana, ripartito

passend in alle großen runden Chafing Dishes von WMF /
fitting for all big round WMF chafing dishes

Porzellan / porcelain

Höhe	height	Inhalt	cap.	Ø	Ø
cm	in.	Ltr.	oz.	cm	in.
7	2 3/4	2 x 1,75	2 x 62	33,5	13 1/4

60.3073.9990



Porzellan-Einsatz

porcelain insert
intérieur en porcelaine
interior porcelana
interno in porcellana

passend in alle großen runden Chafing Dishes von WMF /
fitting for all big round WMF chafing dishes

Porzellan / porcelain

Höhe	height	Inhalt	cap.	Ø	Ø
cm	in.	Ltr.	oz.	cm	in.
7	2 3/4	3,75	131,3	33,5	13 1/4

60.3072.9990



Eier-Einsatz, rund

insert for boiled eggs, round
 récipient pour oeufs à la coque, rond
 interior para huevos cocidos, redondo
 inserto uovo, rotondo

für 24 Eier, passend in alle großen runden Chafing Dishes von WMF /
 for 24 eggs, fitting for all big round WMF chafing dishes

Cromargan® / stainless 18/10

Ø	Ø
cm	in.
34	13 1/2

06.3292.6030



Sauceneinsatz

sauce insert
 garniture pour saucière
 interior para salsas
 interno per salsa

passend in alle WMF Portions-Chafing Dishes /
 fitting for all WMF chafing dishes small size

Cromargan® / stainless 18/10

Höhe	height	Inhalt	cap.	Ø	Ø
cm	in.	Ltr.	oz.	cm	in.
11,6	4 1/2	1	35	16 (Beh.)	6 1/4 (pot)

Ring / ring

Saucenbehälter / sauce pot

06.3313.6044

06.3313.6040



Porzellan-Einsätze

porcelain insert
 intérieur en porcelaine
 interior de porcelana
 interno in porcellana

Porzellan weiß / porcelain white

Inhalt	cap.	Ø	Ø
Ltr.	oz.	cm	in.
1,5	52,5	20	8

60.3004.0690



Platte, rund

platter, round
 plat, rond
 fuente, redonda
 vassoio, rotondo

passend in alle WMF Portions-Chafing Dishes /
 fitting for all WMF chafing dishes small size

Cromargan® / stainless 18/10

Ø	Ø
cm	in.
23	9

06.3306.6044



Gastronorm-Einsatz, zu Chafing Dish

GN insert, for chafing dish
 GN intérieur, pour chafing dish
 GN interior, para chafing dish
 GN interno, per chafing dish

Beachten: Gastronorm-Einsätze passen **nicht** in die Eiswanne von combiNation buffet, sondern nur in mittlere und hohe Rahmen! / GN inserts do **not** fit in the ice tray of combiNation buffet, but only fit in frames medium and high!

Cromargan® / stainless 18/10

Einsatz GN 1/3 / insert GN 1/3

Größe cm	size in.	Inhalt Ltr.	cap. oz.	
6,5 x 17,5 x 32,5	2 1/2 x 7 x 12 3/4	2,4	84	19.9955.0577
10 x 17,5 x 32,5	4 x 7 x 12 3/4	3,75	133	19.9955.0578



Einsatz GN 1/2 / insert GN 1/2

Größe cm	size in.	Inhalt Ltr.	cap. oz.	
6,5 x 26 x 32,5	2 1/2 x 10 1/4 x 12 3/4	3,8	133	19.9955.0581
10 x 26 x 32,5	4 x 10 1/4 x 12 3/4	6	210	19.9955.0582

Einsatz GN 2/3 / insert GN 2/3

Größe cm	size in.	Inhalt Ltr.	cap. oz.	
6,5 x 35,4 x 32,5	2 1/2 x 14 x 12 3/4	5,5	192,5	19.9955.0585
10 x 35,4 x 32,5	4 x 14 x 12 3/4	8,5	297,5	19.9955.0586

Einsatz GN 1/1 / insert GN 1/1

Größe cm	size in.	Inhalt Ltr.	cap. oz.	
6,5 x 53 x 32,5	2 1/2 x 20 3/4 x 12 3/4	8,5	297,5	19.9955.0589
10 x 53 x 32,5	4 x 20 3/4 x 12 3/4	13,3	465,5	19.9955.0590



Porzellan-Einsatz, zu Chafing Dish

GN porcelain insert, for chafing dish

GN intérieur en intérieur, pour chafing dish

GN interior porcelana, para chafing dish

GN interno in porcellana, per chafing dish

Beachten: Gastronorm-Einsätze passen **nicht** in die Eiswanne von combiNation buffet! /

GN inserts do **not** fit in the ice tray of combiNation buffet!

Porzellan / porcelain

Einsatz GN $\frac{1}{3}$ / insert GN $\frac{1}{3}$

Größe cm	size in.	Inhalt Ltr.	cap. oz.	
2 x 17,5 x 32,5	$\frac{3}{4}$ x 7 x $12\frac{3}{4}$	0,4	14	60.3055.9990
6,5 x 17,5 x 32,5	$2\frac{1}{2}$ x 7 x $12\frac{3}{4}$	1,9	64,2	60.3047.9990

Einsatz GN $\frac{1}{2}$ / insert GN $\frac{1}{2}$

Größe cm	size in.	Inhalt Ltr.	cap. oz.	
2 x 26,5 x 32,5	$\frac{3}{4}$ x $10\frac{1}{2}$ x $12\frac{3}{4}$	0,7	24,5	60.3054.9990
6,5 x 26,5 x 32,5	$2\frac{1}{2}$ x $10\frac{1}{2}$ x $12\frac{3}{4}$	3,3	111,54	60.3045.9990

Einsatz GN $\frac{2}{3}$ / insert GN $\frac{2}{3}$

Größe cm	size in.	Inhalt Ltr.	cap. oz.	
2 x 35,4 x 32,5	$\frac{3}{4}$ x 14 x $12\frac{3}{4}$	0,8	28	60.3056.9990
6,5 x 35,4 x 32,5	$2\frac{1}{2}$ x 14 x $12\frac{3}{4}$	4,65	157,17	60.3046.9990

Einsatz GN $\frac{1}{1}$ / insert GN $\frac{1}{1}$

Größe cm	size in.	Inhalt Ltr.	cap. oz.	
2 x 53 x 32,5	$\frac{3}{4}$ x $20\frac{3}{4}$ x $12\frac{3}{4}$	1,4	49	60.3053.9990
6,5 x 53 x 32,5	$2\frac{1}{2}$ x $20\frac{3}{4}$ x $12\frac{3}{4}$	7,3	246,74	60.3044.9990

Einsatz GN $\frac{2}{4}$ / insert GN $\frac{2}{4}$

Größe cm	size in.	Inhalt Ltr.	cap. oz.	
2 x 16 x 53	$\frac{3}{4}$ x $6\frac{1}{4}$ x $20\frac{3}{4}$	0,6	21	60.3057.9990
6,5 x 16 x 53	$2\frac{1}{2}$ x $6\frac{1}{4}$ x $20\frac{3}{4}$	2,5	87,5	60.3048.9990





Heizelement

heating element
 plaque électrique
 placa calentadora
 piastra riscaldante

für WMF Chafing Dishes GN 1/1 ohne Rolltop-Deckel /
 suitable for all WMF chafing dishes GN 1/1 without full rolltop cover

Größe	size
cm	in.
24 x 24	9 1/2 x 9 1/2

Heizelement 230 V / 1000 W /
 heating element 230 V / 1000 W 06.2082.6044

Heizelement 110 V / 1000 W /
 heating element 110 V / 1000 W 06.2082.9990



Adapter für Elektroheizteil

holder for heating element
 adaptateur pour plaque électrique
 adaptador para placa calentadora
 adattatore per piastra riscaldante

zum problemlosen Einsatz von Heizelement 06.2082.6044 und
 06.2082.9990 für WMF Chafing Dishes GN 1/1 ohne Rolltop-Deckel /
 suitable for easy use of heating element 06.2082.6044 and
 06.2082.9990 for all WMF chafing dishes GN 1/1 without full rolltop
 cover

Cromargan® / stainless 18/10

Höhe	height	Größe	size	
cm	in.	cm	in.	
7	2 3/4	25 x 20	9 3/4 x 7 3/4	06.3272.6039



Heizelement

heating element
 plaque électrique
 placa calentadora
 piastra riscaldante

für alle großen runden WMF Chafing Dishes, VDE geprüft /
 suitable for all big round WMF chafing dishes, VDE proved

Größe	size
cm	in.
20 x 20	7 3/4 x 7 3/4

Heizelement 140-230 V / 270 W /
 heating element 140-230 V / 270 W 55.0096.6044

Heizelement 100-120 V / 230 W /
 heating element 100-120 V / 230 W 55.0096.9990

Heizelement 230 V / 550 W mit Regler /
 heating element 230 V / 550 W heat adjustable 06.2095.6046



Heizelement, 140-230 V / 220 W

heating element, 140-230 V / 220 W
 plaque électrique, 140-230 V / 220 W
 place calentadora, 140-230 V / 220 W
 piastra riscaldante, 140-230 V / 220 W

für WMF Chafing Dishes Hot&Fresh GN $\frac{2}{3}$ und rund /
 suitable for WMF chafing dishes Hot&Fresh GN $\frac{2}{3}$ and round

Größe	size
cm	in.
25 x 20	9 $\frac{3}{4}$ x 7 $\frac{3}{4}$

55.0095.6044



Heizelement

heating element
 plaque électrique
 placa calentadora
 piastra riscaldante

für WMF Chafing Dishes GN $\frac{1}{1}$ und GN $\frac{2}{3}$, VDE geprüft /
 suitable for WMF chafing dishes GN $\frac{1}{1}$ and GN $\frac{2}{3}$, VDE proved

Größe	size
cm	in.
25 x 20	9 $\frac{3}{4}$ x 7 $\frac{3}{4}$

Heizelement 230 V / 600 W /
 heating element 230 V / 600 W

55.0097.6044

Heizelement 120 V / 600 W /
 heating element 120 V / 600 W

55.0097.9990

Heizelement 230 V / 700 W mit Regler /
 heating element 230 V / 700 W heat adjustable

06.3286.6046



Brennstoffdosenhalter

burner holder
 porte brûleur
 soporte quemador
 fornello

zur problemlosen Umstellung von elektrischer Heizung auf Brennstoff.
 Passend für alle WMF Chafing Dishes GN $\frac{1}{1}$ /
 for uncomplicated conversion from electrical to burner heating. Fitting
 for all WMF chafing dishes GN $\frac{1}{1}$

Cromargan® / stainless 18/10

Größe	size
cm	in.
20 x 26 x 8,2	8 x 10 $\frac{1}{4}$ x 3 $\frac{3}{4}$

06.3322.6039



Brennstoffdosenhalter

burner holder
 porte brûleur
 soporte quemador
 fornello

zur problemlosen Umstellung von elektrischer Heizung auf Brennstoff.
 Passend für alle runden Chafing Dishes CHANGE /
 for uncomplicated conversion from electrical to burner heating. Fitting
 for all round WMF chafing dishes CHANGE

Cromargan® / stainless 18/10

Höhe	height	Größe	size	
cm	in.	cm	in.	
8,5	3 1/4	12,5 x 20	5 x 8	06.3940.6039



Brennstoffdosen-Regulierer

sterno control
 cartouches de combustible - régulantes
 regulador de botes de material combustible
 regolatore di combustibile

passend für alle WMF Chafing Dishes, ermöglicht eine Regulierung der
 Flamme /
 fitting for all WMF chafing dishes, makes a regulation of flame possible

Cromargan® / stainless 18/10

Länge	length	Ø	Ø	
cm	in.	cm	in.	
9,2 (Griff)	3 1/2 (of handle)	8,5	3 1/4	06.2100.6030



Brennstoffdose

solid alcohol
 alcool solidifié
 combustible
 alcool solido

Großpackung 36 St. /
 large package 36 pcs.

Inhalt	cap.	
Ltr.	oz.	
je Dose 0,2	each tin 7	60.3002.0690



Besteckablage

rack for utensils
 support couverts à servir
 soporte cubiertos servir
 porta posante

passend in alle WMF Chafing Dishes GN 1/1 in Standard- und Economy-
 Ausführung /
 fitting for all WMF chafing dishes GN 1/1 design Standard and Economy

Cromargan® / stainless 18/10

Größe	size	
cm	in.	
30 x 9	12 x 3 1/2	06.3296.6030



Besteckablage

rack for utensils
support couverts à servir
soporte cubiertos servir
porta posante

zum Einhängen in die Rahmen aller GN 1/1 Chafing Dishes CHANGE und VITALIS PRO, kann auch ohne Chafing Dish freistehend verwendet werden. /

to hinge in the frames of all GN 1/1 chafing dishes CHANGE and VITALIS PRO, can also be used on its own without Chafing Dish.

Cromargan®, Porzellan weiß / stainless 18/10, porcelain white

Tablett/Besteckhalter / tray/cutlery holder

Größe	size
cm	in.
27,9 x 12 x 7,1	11 x 4 ³ / ₄ x 2 ³ / ₄

06.3539.6040

Porzellanschale / porcelain bowl

Größe	size
cm	in.
21 x 8,7 x 3,25	8 ¹ / ₄ x 3 ¹ / ₂ x 1 ¹ / ₄

60.3540.9990



Chafing Dish - Besteck

chafing dish serving set
service pour chafing dish
cubiertos para chafing dish
posate chafing dish

Cromargan® / stainless 18/10



Chafing Dish Gabel / chafing dish fork

Länge	length
cm	in.
26	10 ¹ / ₄

12.8386.6042



Chafing Dish Löffel / chafing dish spoon

Länge	length
cm	in.
26	10 ¹ / ₄

12.8386.6041



Chafing Dish Gabel / chafing dish fork

Länge	length
cm	in.
26	10 ¹ / ₄

12.8249.6040



Salatgabel / salad fork

Länge	length
cm	in.
26	10 ¹ / ₄

12.8343.6042



Chafing Dish Gabel / chafing dish fork

Länge	length
cm	in.
32,5	12 ³ / ₄

12.8381.6042



Chafing Dish Löffel / chafing dish spoon

Länge	length
cm	in.
32,5	12 ³ / ₄

12.8381.6041



Fleischgabel / serving fork

Länge	length
cm	in.
32,5	12 ³ / ₄

12.8382.6040

Nudellöffel / pasta serving spoon

Länge	length
cm	in.
31,5	12 ¹ / ₂

12.8383.6040



Chafing Dish Gabel / chafing dish fork

Länge	length
cm	in.
39	15 ¹ / ₄

12.8387.6042



Chafing Dish Löffel / chafing dish spoon

Länge	length
cm	in.
39	15 ¹ / ₄

12.8387.6041



**Coffee Urn, „Basic“
CHANGE**

coffee urn, „Basic“
coffee urn, „Basic“
urna de café, „Basic“
coffee urn, „Basic“

elektrisch und mit Brennstoff beheizbar. Heizelemente (110-265 V/ 150 W) und Brennstoffhalter bitte separat bestellen. Garantie siehe Betriebsanleitung. / electrically and sterno heated. Please order heating elements (110-265 V/150W) separately. Refer to operating instructions for warranty.

Cromargan® / stainless 18/10

Höhe	height	Inhalt	cap.	Ø	Ø	
cm	in.	Ltr.	oz.	cm	in.	
54,5	21½	10	338	26	10¼	06.1520.6040
63,2	25	15	507	26	10¼	06.1525.6040

Zubehör / accessory:

Heizelement Coffee Urn / heating element 19.9999.9879

Brennstoffdose / solid alcohol 60.3002.0690

Inhalt cap.
Ltr. oz.
je Dose 0,2 each tin 7

Brennstoffhalter Coffee Urn / burner holder coffee urn 06.1520.6039

Höhe	height	Ø	Ø
cm	in.	cm	in.
12,8	5	17	6¾



**Coffee Urn, „Palast“
CHANGE**

coffee urn, „Palast“
coffee urn, „Palast“
urna de café, „Palast“
coffee urn, „Palast“

elektrisch und mit Brennstoff beheizbar. Heizelemente (110-265 V/ 150 W) und Brennstoffhalter bitte separat bestellen. Garantie siehe Betriebsanleitung. / electrically and sterno heated. Please order heating elements (110-265 V/150W) separately. Refer to operating instructions for warranty.

Cromargan® teilvergoldet / stainless 18/10 partly gold plated

Höhe	height	Inhalt	cap.	Ø	Ø	
cm	in.	Ltr.	oz.	cm	in.	
58,2	23	10	338	26	10¼	06.1521.6210
66,9	26¼	15	507	26	10¼	06.1526.6210

Zubehör / accessory:

Heizelement Coffee Urn / heating element 19.9999.9879

Brennstoffdose / solid alcohol 60.3002.0690

Inhalt cap.
Ltr. oz.
je Dose 0,2 each tin 7

Brennstoffhalter Coffee Urn / burner holder coffee urn 06.1520.6039

Höhe	height	Ø	Ø
cm	in.	cm	in.
12,8	5	17	6¾



**Coffee Urn, „Manhattan“
CHANGE**

coffee urn, „Manhattan“
coffee urn, „Manhattan“
urna de café, „Manhattan“
coffee urn, „Manhattan“

elektrisch und mit Brennstoff beheizbar. Heizelemente (110-265 V/ 150 W) und Brennstoffhalter bitte separat bestellen. Garantie siehe Betriebsanleitung. / electrically and sterno heated. Please order heating elements (110-265 V/150W) separately. Refer to operating instructions for warranty.

Cromargan® / stainless 18/10

Höhe	height	Inhalt	cap.	Ø	Ø	
cm	in.	Ltr.	oz.	cm	in.	
54,5	21 1/2	10	338	26	10 1/4	06.1524.6040
63,2	25	15	507	26	10 1/4	06.1529.6040

Zubehör / accessory:

Heizelement Coffee Urn / heating element 19.9999.9879

Brennstoffdose / solid alcohol 60.3002.0690

Inhalt cap.
Ltr. oz.
je Dose 0,2 each tin 7

Brennstoffhalter Coffee Urn / burner holder coffee urn 06.1520.6039

Höhe	height	Ø	Ø
cm	in.	cm	in.
12,8	5	17	6 3/4



**Brennstoffhalter Coffee Urn
CHANGE**

burner holder coffee urn
porte brûleur coffee urns
soporte quemador urna de café
fornello coffee urn

passend zu Coffee Urns 10 und 15 I CHANGE / fitting for coffee urns 10 and 15 I CHANGE

Cromargan® / stainless 18/10

Höhe	height	Ø	Ø	
cm	in.	cm	in.	
12,8	5	17	6 3/4	06.1520.6039

Heizelement Coffee Urn

heating element
plaque électrique
placa calentadora
piastra riscaldante

passend zu Coffee Urns 10 und 15 I CHANGE, 110 - 265 V, 150 W, selbstregelnd / fitting for coffee urns 10 and 15 I CHANGE, 110 - 265 V, 150 W, self-regulating



19.9999.9879

**Schild mit Kette**

name plate with chain

étiquette avec chaîne

etiqueta con cadena

targhetta con aggancio a catenella

passend für Coffee Urns, individuelle Kennzeichnung möglich. Preis auf Anfrage. /

fitting on Coffee Urns, individual engraving possible. Please ask for respective costs.

Cromargan® / stainless 18/10

Länge	length
cm	in.
63	24 ³ / ₄

06.3151.6040

Cerealien Dispenser
CHANGE
cereal dispenser
CHANGE

... flaking it easy!



Produktvarianten
range of products



CEREALIEN / CEREAL DISPENSER
Reihenlösung / in-line



CEREALIEN / CEREAL DISPENSER
rund, drehbar / round, rotatable



Produktvorteile

Hygienisch – Die Behälter sind leicht zu entnehmen, nachzufüllen und komplett spülmaschinengeeignet.

Einfach – Die portionierte Entnahme der Cerealien durch Drehen des Bedienknopfes erklärt sich dem Gast von selbst.

Kompakt – Die kompakte Bauweise spart viel vom sowieso knapp bemessenen Platz auf jedem Buffet.

Schön – Das CHANGE-Konzept von WMF Hotel ist ein optisch gelungener Blickfang für jedes Buffet.

Material und Verarbeitung

Das hochwertige Cromargan® ist je nach Modell mattiert oder poliert und teilweise um vergoldete Zierelemente ergänzt.

Die Cerealien-Röhre besteht aus transparentem PMMA, alle anderen Kunststoffteile aus schwarzem POM. Beide Kunststoffe sind absolut geruchsneutral und lebensmittelgeeignet.

Platzsparend – Die runde, drehbare Variante ist besonders schmal.

Advantages of the products

Hygienic – The reservoirs are easy to remove, easy to refill and fully dishwasher safe.

Straightforward – Diners will find portioned dispensing of cereals by turning the knob self-explanatory.

Compact – The compact construction saves lots of precious space on any buffet.

Good-looking – The WMF Hotel's CHANGE concept is aesthetically pleasing for any buffet.

Material and finish –

The high-grade Cromargan® is either satin finished or polished, according to the model. Some models are decorated with gold plate.

The cereal chutes are made from clear PMMA. All other plastic parts are black POM. Both plastics are totally odourless and food safe.

Space-saving – The rotatable round version is very slim.



Cerealiendispenser, drehbar „Basic“ CHANGE

cereal dispenser, rotatable, „Basic“
dispenseur de céréales, rotatif, „Basic“
dispensador de cereales, rotativo, „Basic“
dispencer cereali, girabile, „Basic“

mit 3 Behältern, drehbar, portionierte und hygienische Entnahme durch Drehen, leicht zu befüllen, spülmaschinengeeignet, Durchmesser Behälter 11,3 cm; Inhalt jeweils 3,5 l; Unterstellhöhe 9,5 cm /
with 3 containers, turnable, hygienic portioning by turning, easy to refill, dishwasher safe, dia. container 4¹/₂ in.; cap. each container 118,3 oz.; clear height 3³/₄ in.

Gestell Cromargan®, Behälter PMMA farblos /
stand stainless 18/10, container PMMA clear

Höhe	height	Ø	Ø
cm	in.	cm	in.
59,7	23 ¹ / ₂	35,7	14

06.3530.6040



Cerealiendispenser, Reihenlösung „Basic“ CHANGE

cereal dispenser, in-line „Basic“
dispenseur de céréales, in-line „Basic“
dispensador de cereales, in-line „Basic“
dispencer cereali, in-line „Basic“

mit 3 Behältern, portionierte und hygienische Entnahme durch Drehen, leicht zu befüllen, spülmaschinengeeignet, Durchmesser Behälter 11,3 cm; Inhalt jeweils 3,5 l; Unterstellhöhe 9,5 cm /
with 3 containers, hygienic portioning by turning, easy to refill, dishwasher safe, dia. container 4¹/₂ in.; cap. each container 118,3 oz.; clear height 3³/₄ in.

Gestell Cromargan®, Behälter PMMA farblos /
stand stainless 18/10, container PMMA clear

Größe	size
cm	in.
39 x 25 x 59,7	15 ¹ / ₄ x 9 ³ / ₄ x 23 ¹ / ₂

06.3640.6040



Cerealidispenser, Reihenlösung „Manhattan“ CHANGE

cereal dispenser, in-line „Manhattan“
 dispenseur de céréales, in-line „Manhattan“
 dispensador de cereales, in-line „Manhattan“
 dispencer cereali, in-line „Manhattan“

mit 3 Behältern, portionierte und hygienische Entnahme durch Drehen, leicht zu befüllen, spülmaschinengeeignet, Durchmesser Behälter 11,3 cm; Inhalt jeweils 3,5 l; Unterstellhöhe 9,5 cm /
 with 3 containers, hygienic portioning by turning, easy to refill, dishwasher safe, diam. container 4 1/2 in.; cap. each container 118,3 oz.; clear height 3 3/4 in.

Gestell Cromargan®, Behälter PMMA farblos /
 stand stainless 18/10, container PMMA clear

Größe	size
cm	in.
39 x 25 x 59,6	15 1/4 x 9 3/4 x 23 1/2

06.3645.6040



Cerealidispenser, Reihenlösung „Palast“ CHANGE

cereal dispenser, in-line „Palast“
 dispenseur de céréales, in-line „Palast“
 dispensador de cereales, in-line „Palast“
 dispencer cereali, in-line „Palast“

mit 3 Behältern, portionierte und hygienische Entnahme durch Drehen, leicht zu befüllen, spülmaschinengeeignet, Durchmesser Behälter 11,3 cm; Inhalt jeweils 3,5 l; Unterstellhöhe 9,5 cm /
 with 3 containers, hygienic portioning by turning, easy to refill, dishwasher safe, diam. container 4 1/2 in.; cap. each container 118,3 oz.; clear height 3 3/4 in.

Gestell Cromargan® teilvergoldet, Behälter PMMA farblos /
 stand stainless 18/10 partly gold plated, container PMMA clear

Größe	size
cm	in.
39 x 25 x 59,6	15 1/4 x 9 3/4 x 23 1/2

06.3641.6210



Wandhalterung Cer.disp., einfach

wall mount for cer. disp., single
simple fixation murale pour disp. à céréales
sujeción sencilla de pared para disp. cereales
supporto per dispenser cereali

einfache Montage an der Wand, für eine Dispenser-Röhre, inkl. Schrauben und Dübel /
easy to fix at the wall, for 1 dispenser pipe, incl. screws and screw anchors

Cromargan® / stainless 18/10

Größe cm	size in.
12,5 x 13,2 x 3,9	5 x 5 ¹ / ₄ x 1 ¹ / ₂

55.0057.6040

Zubehör / accessory:

Cerealienbehälter / container cereal dispenser

06.3530.6041

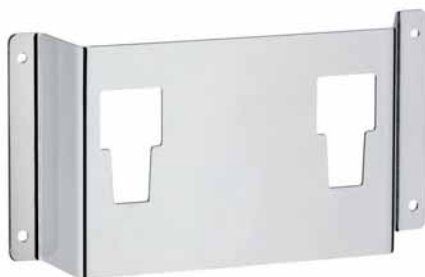

Wandhalterung Cer.disp., doppelt

wall mount for cer. disp., double
double fixation murale p. disp. à céréales
sujeción doble de pared para disp. Cereales
supporto per dispenser cereali dop.

einfache Montage an der Wand, für 2 Dispenser-Röhren, inkl. Schrauben und Dübel /
easy to fix at the wall, for 2 dispenser pipes, incl. screws and screw anchors

Cromargan® / stainless 18/10

Größe cm	size in.
25 x 13,2 x 3,9	9 ³ / ₄ x 5 ¹ / ₄ x 1 ¹ / ₂

55.0056.6040

Zubehör / accessory:

Cerealienbehälter / container cereal dispenser

06.3530.6041

Saft- und Milchdispenser CHANGE

Juice- and Milk Dispenser CHANGE



Saft- und Milchdispenser »CHANGE«

Einfach schön

Alles, was auf den Tisch Ihres Buffets kommt, sollte einen einheitlichen Stil repräsentieren: Ihren. Die breite Palette der „CHANGE“-Dispenser bietet für jedes Ambiente und jeden Geschmack das passende Modell. Das Design von WMF signalisiert Ihrem Gast »hier wird Wert auf das Detail gelegt«.

Einfach erfrischend

Das Prinzip ist simpel und effektiv: Die Edelstahl-Eisröhre wird mit Crash Ice befüllt und in die komplette Flüssigkeit getaucht. Die Kühlung erfolgt also nicht nur von unten sondern im gesamten Behälter und hält dadurch lange an.

Juice- and Milchdispenser »CHANGE«

Simply beautiful

Everything on your buffet table should represent a consistent style: your own. The wide range of »CHANGE« dispensers includes the right model for every environment and for every taste. The WMF design tells the customer that this is a place »where details matter«.

Simply freshness

The principle is simple and effective. The stainless steel ice tube is filled with crushed ice and lowered all the way into the liquid. That way, the product is not merely chilled from below, but all the way through, to keep it cooler longer.



Saft- und Milchdispenser »CHANGE«

Starke Typen

Chafing Dishes, Dispenser für Saft, Milch und Cerealien oder Coffee Urns, es passt alles zusammen.

Einfach Qualität

Qualität und Funktionalität aus Tradition steht auch hier ganz oben.

Hochwertiges Cromargan® ist je nach Modell mattiert oder poliert und teilweise um vergoldete Zierelemente ergänzt. Der Flüssigkeitsbehälter besteht aus geruchsneutralem, hochwertigem SAN-Kunststoff, transparent bei Saft, lichtundurchlässig weiß bei Milch.

Motive für die Schilder zum downloaden, umfangreiches Zubehör und Ersatzteile finden Sie unter www.wmf-hotel.de



Stufenlos höhenverstellbar
Step-free height adjustable



Juice- and Milk Dispenser »CHANGE«

Perfect match

Everything fits together: Chafing dishes, coffee urns, juice-, milk- and cereal dispensers.

Simply quality

Quality and functionality born in tradition is our top priority.

The high-quality stainless steel is available in satin or polished finish. Some models have gold-plated decorative elements. The product container is made from odourless, high-quality SAN plastic. The juice container is clear, the milk container is opaque white. extensive list of parts and accessories are available at www.wmf-hotel.de

Download-motifs for the front, extensive list of spare parts and accessories are available at www.wmf-hotel.de





Saftdispenser, „Basic“ CHANGE

juice dispenser, „Basic“
dispenseur de jus, „Basic“
dispensador de zumo, „Basic“
dispenser per succhi di frutta, „Basic“

individuell höhenverstellbar, tropffreier, hygienischer Auslauf, Kühlmöglichkeit durch Eisröhre (Zubehör). Attraktive Motive für die Frontseite zum Download unter www.wmf-hotel.de / individually height adjustable, clear labelling hygienic spout, cooling with ice tube (accessory). Attractive motifs for the frontside for download at www.wmf-hotel.de

Gestell Cromargan®, Behälter SAN-Kunststoff transparent / stand stainless 18/10, container SAN plastic clear

Mindesthöhe cm	min. height in.	Maximalhöhe cm	max. height in.	Größe cm	size in.
52	20½	60	23½	30,5 x 20	12 x 8

Inhalt mit Eisröhre Ltr.	cap. incl. ice tube oz.	Inhalt ohne Eisröhre Ltr.	cap. w/o ice tube oz.
5	175	6,5	227,5

06.3130.6040

Zubehör / accessory:

Eisröhre / ice tube	06.3130.6043
Transportgestell / transport unit	06.3130.6049



Saftdispenser, „Manhattan“ CHANGE

juice dispenser, „Manhattan“
dispenseur de jus, „Manhattan“
dispensador de zumo, „Manhattan“
dispenser per succhi di frutta, „Manhattan“

individuell höhenverstellbar, tropffreier, hygienischer Auslauf, Kühlmöglichkeit durch Eisröhre (Zubehör). Attraktive Motive für die Frontseite zum Download unter www.wmf-hotel.de / individually height adjustable, clear labelling hygienic spout, cooling with ice tube (accessory). Attractive motifs for the frontside for download at www.wmf-hotel.de

Gestell Cromargan®, teilmattiert, Behälter SAN-Kunststoff transparent / stand stainless 18/10, partly satin finished, container SAN plastic clear

Mindesthöhe cm	min. height in.	Maximalhöhe cm	max. height in.	Größe cm	size in.
52	20½	60	23½	30,5 x 20	12 x 8

Inhalt mit Eisröhre Ltr.	cap. incl. ice tube oz.	Inhalt ohne Eisröhre Ltr.	cap. w/o ice tube oz.
5	175	6,5	227,5

06.3135.6040

Zubehör / accessory:

Eisröhre / ice tube	06.3130.6043
Transportgestell / transport unit	06.3130.6049



Saftdispenser, „Palast“ CHANGE

juice dispenser, „Palast“
dispenseur de jus, „Palast“
dispensador de zumo, „Palast“
dispenser per succhi di frutta, „Palast“

individuell höhenverstellbar, tropffreier, hygienischer Auslauf, Kühlmöglichkeit durch Eisröhre (Zubehör). Attraktive Motive für die Frontseite zum Download unter www.wmf-hotel.de/
individually height adjustable, clear labelling hygienic spout, cooling with ice tube (accessory). Attractive motifs for the frontside for download at www.wmf-hotel.de

Gestell Cromargan®, teilvergoldet, Behälter SAN-Kunststoff transparent / stand stainless 18/10, partly gold plated, container SAN plastic clear

Mindesthöhe cm	min. height in.	Maximalhöhe cm	max. height in.	Größe cm	size in.
52	20½	60	23½	30,5 x 20	12 x 8

Inhalt mit Eisröhre Ltr.	cap. incl. ice tube oz.	Inhalt ohne Eisröhre Ltr.	cap. w/o ice tube oz.
5	175	6,5	227,5

06.3131.6210

Zubehör / accessory:

Eisröhre / ice tube	06.3130.6043
Transportgestell / transport unit	06.3130.6049



Milchdispenser, „Basic“ CHANGE

milk dispenser, „Basic“
dispenseur de lait, „Basic“
dispensador leche, „Basic“
dispenser latte, „Basic“

individuell höhenverstellbar, tropffreier, hygienischer Auslauf, Kühlmöglichkeit durch Eisröhre (Zubehör). Attraktive Motive für die Frontseite zum Download unter www.wmf-hotel.de/
individually height adjustable, clear labelling hygienic spout, cooling with ice tube (accessory). Attractive motifs for the frontside for download at www.wmf-hotel.de

Gestell Cromargan®, Behälter SAN-Kunststoff lichtundurchlässig / stand stainless 18/10, container SAN plastic opaque white

Mindesthöhe cm	min. height in.	Maximalhöhe cm	max. height in.	Größe cm	size in.
52	20½	60	23½	30,5 x 20	12 x 8

Inhalt mit Eisröhre Ltr.	cap. incl. ice tube oz.	Inhalt ohne Eisröhre Ltr.	cap. w/o ice tube oz.
5	175	6,5	227,5

06.3390.6040

Zubehör / accessory:

Eisröhre / ice tube	06.3130.6043
Transportgestell / transport unit	06.3130.6049



Milchdispenser, „Manhattan“ CHANGE

milk dispenser, „Manhattan“
dispenseur de lait, „Manhattan“
dispensador leche, „Manhattan“
dispenser latte, „Manhattan“

individuell höhenverstellbar, tropffreier, hygienischer Auslauf,
Kühlmöglichkeit durch Eisröhre (Zubehör). Attraktive Motive für die
Frontseite zum Download unter www.wmf-hotel.de/
individually height adjustable, clear labelling hygienic spout, cooling
with ice tube (accessory). Attractive motifs for the frontside for
download at www.wmf-hotel.de

Gestell Cromargan®, teilmattiert, Behälter SAN-Kunststoff
lichtundurchlässig /

stand stainless 18/10, partly satin finished, container SAN plastic
opaque white

Mindesthöhe cm	min. height in.	Maximalhöhe cm	max. height in.	Größe cm	size in.
52	20½	60	23½	30,5 x 20	12 x 8

Inhalt mit Eisröhre Ltr.	cap. incl. ice tube oz.	Inhalt ohne Eisröhre Ltr.	cap. w/o ice tube oz.
5	175	6,5	227,5

06.3395.6040

Zubehör / accessory:

Eisröhre / ice tube 06.3130.6043

Transportgestell / transport unit 06.3130.6049



Milchdispenser, „Palast“ CHANGE

milk dispenser, „Palast“
dispenseur de lait, „Palast“
dispensador leche, „Palast“
dispenser latte, „Palast“

individuell höhenverstellbar, tropffreier, hygienischer Auslauf,
Kühlmöglichkeit durch Eisröhre (Zubehör). Attraktive Motive für die
Frontseite zum Download unter www.wmf-hotel.de/
individually height adjustable, clear labelling hygienic spout, cooling
with ice tube (accessory). Attractive motifs for the frontside for
download at www.wmf-hotel.de

Gestell Cromargan®, teilvergoldet, Behälter SAN-Kunststoff
lichtundurchlässig /

stand stainless 18/10, partly gold plated, container SAN plastic opaque
white

Mindesthöhe cm	min. height in.	Maximalhöhe cm	max. height in.	Größe cm	size in.
52	20½	60	23½	30,5 x 20	12 x 8

Inhalt mit Eisröhre Ltr.	cap. incl. ice tube oz.	Inhalt ohne Eisröhre Ltr.	cap. w/o ice tube oz.
5	175	6,5	227,5

06.3391.6210

Zubehör / accessory:

Eisröhre / ice tube 06.3130.6043

Transportgestell / transport unit 06.3130.6049



Eisröhre

ice tube
tube à glace
tubo para hielo
tubo in acciaio

mit Crash Ice zu befüllen. Passend zu allen Saft- und Milchdispensern
CHANGE /
to be filled up with crash-ice. Fitting for all juice and milk dispensers
CHANGE

Cromargan® / stainless 18/10

Höhe	height	Inhalt	cap.	Ø	Ø upper
cm	in.	Ltr.	oz.	cm	in.
27	10 ³ / ₄	1	35	7,5	35

06.3130.6043



Transportgestell

transport unit
châssis de transport
bastidor de transporte
carrello da trasporto

zum Transport und zur Aufbewahrung von befüllten Behältern der
Dispenser CHANGE /
for transport and storage of filled containers for the CHANGE
dispensers

Cromargan® / stainless 18/10

Größe	size
cm	in.
18 x 15 x 8	7 x 6 x 3 ¹ / ₄

06.3130.6049



Saftbar, mit Gläserbord

juice bar, with glass holder
bar à jus de fruit, avec étagère pour verres
set para zumos, con portavasos
set girevole per succhi di frutta

bestehend aus: Gestell, 4 Kühlpellets /
consisting of: stand, 4 cooling elements

drehbar /
turnable

Cromargan®, Plexiglas / stainless 18/10, plexiglass

Höhe	height	Ø	Ø
cm	in.	cm	in.
47	18 ¹ / ₂	47	18 ¹ / ₂

06.3232.6040

Zubehör / accessory:

Glaskrug / glass pitcher

60.3061.9990

Inhalt	cap.
Ltr.	oz.
1,5	52,5

Ersatzteil / spare part:

Kühlpellet / cooling element

19.9999.5850

Ø	Ø
cm	in.
16	6 ¹ / ₄





Cerealien-/Saft-Set

set for cereal/juice dispenser
 presentoir a cereales/jus de fruit
 set para cereales/jugo
 set per cereali/succhi

bestehend aus Gestell und 3 Schüttflöten mit Deckel, Inhalt je 2 Ltr., für Saft, Milch oder Cerealien /
 consisting of base and 3 containers with lid, cap. 67,6 oz. each, for juice, milk or cereals

Cromargan®, SAN klar / Cromargan®, SAN clear

Größe	size	
cm	in.	
42,5 x 16,4 x 29,4	16 ³ / ₄ x 6 ¹ / ₂ x 11 ¹ / ₂	06.3648.6040

Ersatzteil / spare part:

Gestell, 3 Ausschnitte / base, for 3 inserts 06.3648.6045

Größe	size
cm	in.
44,5 x 17,2 x 3	17 ¹ / ₂ x 6 ³ / ₄ x 1 ¹ / ₄

Cerealien/Saft-Flöte / cereal/juice flute 06.8253.6040

Höhe	height	Inhalt	cap.	Ø	Ø
cm	in.	Ltr.	oz.	cm	in.
29,4	11 ¹ / ₂	2	67,6	12,6	5

Buffet-Set, Glas

buffet set, glass
 ensemble buffet, verre
 juego de bufete, cristal
 set per buffet, vetro

bestehend aus Gestell und 3 Gläsern (Inhalt je 0,7 Ltr.) inkl. Deckel mit Beschriftungsmöglichkeit. Beschriftungs-Beispiele zum Download auf www.wmf-hotel.de /
 consisting of base with 3 glasses (cap. 23,66 oz. each) incl. lid. Motifs for labelling available for download on www.wmf-hotel.de

Cromargan®, Glas / stainless 18/10, glass

Größe	size	
cm	in.	
44,5 x 17,2 x 13	17 ¹ / ₂ x 6 ³ / ₄ x 5	06.8242.6040

Ersatzteil / spare part:

Gestell, 3 Ausschnitte / base, for 3 inserts 06.3648.6045

Größe	size
cm	in.
44,5 x 17,2 x 3	17 ¹ / ₂ x 6 ³ / ₄ x 1 ¹ / ₄

Glasbehälter / glass bowl 60.8241.9990

Höhe	height	Inhalt	cap.	Ø	Ø
cm	in.	Ltr.	oz.	cm	in.
13	5	0,75	25,35	10,5	4 ¹ / ₄

Deckel, mit Plexihülle / lid, with plexi cover 06.8241.6042

Plexihülle für Deckel / plastic holder for lid 60.8241.9996

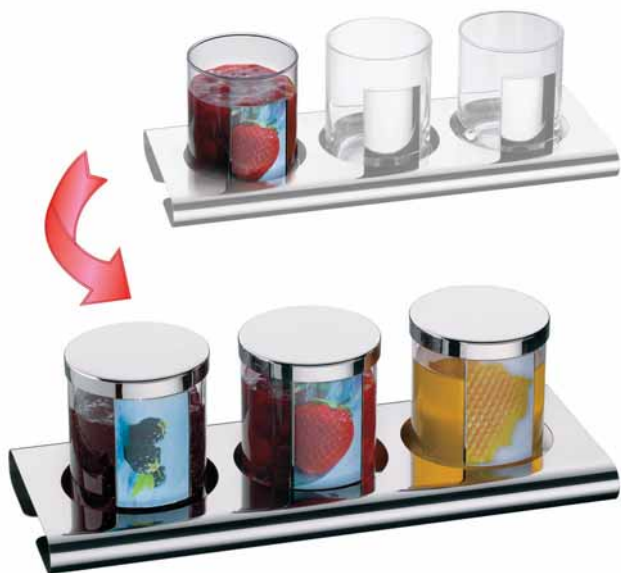



Buffet-Set, Porzellan

buffet set, porcelain
ensemble buffet, porcelaine
juego de bufete, porcelana
set per buffet, porcellana

bestehend aus Gestell und 3 Porzellanbehältern (Inhalt je 0,65 Ltr.)
inkl. Deckel mit Beschriftungsmöglichkeit. Beschriftungs-Beispiele zum
Download auf www.wmf-hotel.de /
consisting of base with 3 porcelain bowls (cap. 21,97 oz. each) incl. lid.
Motifs for labelling available for download on www.wmf-hotel.de

Cromargan®, Porzellan / stainless 18/10, porcelain

Größe	size	
cm	in.	
44,5 x 17,2 x 13	17 ¹ / ₂ x 6 ³ / ₄ x 5	06.8257.6040

Ersatzteil / spare part:

Gestell, 3 Ausschnitte / base, for 3 inserts 06.3648.6045

Größe	size
cm	in.
44,5 x 17,2 x 3	17 ¹ / ₂ x 6 ³ / ₄ x 1 ¹ / ₄

Porzellanbehälter / porcelain bowl 60.8258.9990

Höhe	height	Inhalt	cap.	Ø	Ø
cm	in.	Ltr.	oz.	cm	in.
13	5	0,65	21,97	10,5	4 ¹ / ₄

Deckel, mit Plexihülle / lid, with plexi cover 06.8241.6042

Plexihülle für Deckel / plastic holder for lid 60.8241.9996



Teller-/Schalengestell

plate and bowl stand
support pour bols à céréales
soporte para platos o fuentes
supporto per piatti e coppe

ohne Glasschalen /
without glass bowls

Cromargan® / stainless 18/10

Höhe	height	Ø Ring	Ø ring
cm	in.	cm	in.
40,4	16	19,5	7 ³ / ₄

06.4394.6040

Zubehör / accessory:

Glasschale, 20 cm / glass bowl, 20 cm 19.9999.8642

Deckel zu Glasschale / lid for glass bowl 06.3010.6042

Dessertgestell

dessert stand
présentoir à gâteau
soporte plato postre
porta piattini per dessert

ohne Gläser /
w/o glasses

Cromargan® / stainless 18/10

Größe	size	
cm	in.	
40,6 x 7 x 4,9	16 x 2 ³ / ₄ x 2	06.8230.6040

Zubehör / accessory:

Glas S / glass S 60.2506.9990





**Dessertgestell
PURE EXCLUSIV**

dessert stand
présentoir à gâteau
soporte plato postre
porta piattini per dessert

Mit 3 Einsätzen für wahlweise Gläser S, Tassen S (o. Abb.) oder Sahnekännchen (o. Abb.) mit oder ohne Deckel von KAFFEEKULTUR. Nicht spülmaschinengeeignet! / With 3 inserts alternatively for glasses S, cups S (w/o pic.) or creamer (w/o pic.) with or w/o lid of CoffeeCulture. Not dishwasher-safe!

Cromargan®, Holz dunkel gebeizt / stainless 18/10, wood dark stained

Teelichtleuchter 3fl. klein / tealight candle stick, small

Größe	size	
cm	in.	
20,5 x 6,2 x 3,7	8 x 2 1/2 x 1 1/2	55.0039.6040

Glas S / glass S

Höhe	height	Inhalt	cap.	
cm	in.	Ltr.	oz.	
7,4	3	0,09	3,2	60.2506.9990



**Dessertgestell
PURE EXCLUSIV**

dessert stand
présentoir à gâteau
soporte plato postre
porta piattini per dessert

Mit 3 Einsätzen für wahlweise Gläser S (o. Abb.), Tassen S (o. Abb.) oder Sahnekännchen mit oder ohne Deckel von KAFFEEKULTUR. Nicht spülmaschinengeeignet! / With 3 inserts alternatively for glasses S (w/o pic.), cups S (w/o pic.) or creamer with or w/o lid of CoffeeCulture. Not dishwasher-safe!

Cromargan®, Holz dunkel gebeizt / stainless 18/10, wood dark stained

Teelichtleuchter 3fl. klein / tealight candle stick, small

Größe	size	
cm	in.	
20,5 x 6,2 x 3,7	8 x 2 1/2 x 1 1/2	55.0039.6040

Sahnekännchen / creamer

Höhe	height	Inhalt	cap.	
cm	in.	Ltr.	oz.	
7	2 3/4	0,08	2,7	55.0033.9990

Deckel mit Ausschnitt / lid with cut-out **55.0031.6040**

Espresso-/Mokkalöffel / demi-tasse spoon **54.9901.6040**



Dessertgestell

dessert stand
présentoir à gâteau
soporte platos postre
porta piattini per dessert

passend für Teller bis Ø 16 cm (ohne Teller) /
fitting for plates Ø 6¹/₄ in. (without plates)

Cromargan® / stainless 18/10

Höhe	height	Ø	Ø	Ø Ring	Ø ring
cm	in.	cm	in.	cm	in.
25,5	10	18,5	7 ¹ / ₄	10,5	4 ¹ / ₄

06.4397.6040



Serviergestell

serving stand
présentoir à assiette
soporte platos
portapiatti

passend für Teller Ø 26 cm (ohne Teller) /
fitting for plates Ø 10¹/₄ in. (without plates)

Cromargan® / stainless 18/10

Höhe	height	Ø	Ø	Ø Ring	Ø ring
cm	in.	cm	in.	cm	in.
40	15 ³ / ₄	28,5	11 ¹ / ₄	18,6	7 ¹ / ₄

06.4395.6040



Etagère, 3-teilig PURE

etagere, 3 parts
étagère, en 3 parties
frutero, de 3 pisos
porta frutta, 3 piani

Cromargan® / stainless 18/10

Höhe	height	Ø Schale	Ø bowl
cm	in.	cm	in.
52,5	20 ³ / ₄	46 / 37 / 28	18 / 14 ¹ / ₂ / 11

06.0470.6040



Mokkaétagère, 3-teilig

PURE

pastry stand, 3 parts
 porte petits fours, en 3 parties
 portapastas, de 3 pisos
 alzata portadolci, 3 piani

Cromargan® / stainless 18/10

Höhe	height	Ø Schale	Ø bowl
cm	in.	cm	in.
22,5	8 ³ / ₄	9 / 14 / 20	3 ¹ / ₂ / 5 ¹ / ₂ / 8

06.6903.6040



Etagère, 3-teilig

BISTRO

etagere, 3 parts
 étagère, en 3 parties
 frutero, de 3 pisos
 porta frutta, 3 piani

Cromargan®, Glas / stainless 18/10, glass

Höhe	height	Ø Schale	Ø bowl
cm	in.	cm	in.
56	22	30 / 38 / 50	11 ³ / ₄ / 15 / 19 ³ / ₄

06.6893.6040

Ersatzteil / spare part:

Glasschale klein / glass plate small	19.9999.8643
Glasschale mittel / glass plate medium	19.9999.8644
Glasschale groß / glass plate large	19.9999.8645



Tortenständer

cake stand
 porte tarte
 porta tarta
 portatorta

mit 3 Ebenen (Ø 20 / 26 / 32 cm). Weitere Ebenen erhältlich auf Anfrage. /

with 3 levels (Ø 20 / 26 / 32 cm). Further levels on request.

Aluminium / aluminium

Ø	Ø
cm	in.
32	12 ¹ / ₂

55.0095.6040



Etagère

etagere
 étagère
 frutero articulado
 porta frutta

ohne Einsätze, Arme drehbar /
 without inserts, insert holders turnable

rostfrei / stainless steel

Höhe	height	Ringe
cm	in.	psc.
51	20	4tlg.
70	27½	6tlg.

06.3010.6040
 06.3011.6040



Glasschale, 20 cm

glass bowl, 20 cm
 coupe verre glasskin, 20 cm
 depósitos de cristal, 20 cm
 interno in vetro, 20 cm

passend in Etagère 06.3010.6040, 06.3011.6040, 06.4394.6040,
 06.2441.6040 combiNation buffet /
 fitting in etagere 06.3010.6040, 06.3011.6040, 06.4394.6040,
 06.2441.6040 combiNation buffet

stapelbar /
 stackable

Höhe	height	Ø	Ø
cm	in.	cm	in.
8,5	3¼	20	8

19.9999.8642



Deckel zu Glasschale

lid for glass bowl
 couvercle pour coupe en verre
 tapa para depósitos de cristal
 coperchio per scodella di vetro

passend auf Glasschale Ø 20 cm 19.9999.8642, einfach zu öffnen durch
 Drehen /
 fitting on glass bowl Ø 8 in. 19.9999.8642, easy to open by turning

Cromargan® / stainless 18/10

Ø	Ø
cm	in.
20	8

06.3010.6042



Tortenplatte

cake plate
plat à tarte
plato tarta
piatto da torta

passend in Etagère 06.3010.6040, 06.3011.6040, 06.2441.6040
combiNation buffet /
fitting in etagere 06.3010.6040, 06.3011.6040, 06.2441.6040
combiNation buffet

Cromargan® / stainless 18/10

Ø	Ø
cm	in.
32	12½

06.3014.6042



Tablett, rund

service tray, round
plateau de service, rond
bandeja, redonda
vassoio, rontondo

passend in Etagère 06.3010.6040, 06.3011.6040, 06.2441.6040
combiNation buffet /
fitting in etagere 06.3010.6040, 06.3011.6040, 06.2441.6040
combiNation buffet

Cromargan® / stainless 18/10

Ø außen	outer Ø	Ø innen	Ø inside
cm	in.	cm	in.
29,5	11½	24,5	9¾

06.3014.6041



Kühlbehälter, mit Kühlpellet

cooler, with cooling element
coupe réfrigérante, avec élément réfrigérante
recipiente, con acumulador de frio
base, con elemento refrigerante

passend in Etagère 06.3010.6040, 06.3011.6040, 06.2441.6040
combiNation buffet zum Kühlen von Tablett 06.3014.6041 und
Tortenplatte 06.3014.6042 /
fitting in etagere 06.3010.6040, 06.3011.6040, 06.2441.6040
combiNation buffet to cool tray 06.3014.6041 and cake plate
06.3014.6042

Cromargan® / stainless 18/10

Ø	Ø
cm	in.
19	7½

06.3014.6044

Ersatzteil / spare part:

Kühlpellet / cooling element 19.9999.5850

Kühlbehälter, ohne Kühlpellet /
cooler, without cooling element 06.3014.6045



Früchtekorb

fruit basket
panier à fruits
frutero
fruttiera

passend in Etagère 06.3010.6040, 06.3011.6040, 06.2441.6040
combiNation buffet nur in Verbindung mit Kühlbehälter 06.3014.6045
(bitte separat bestellen) /
fitting together with cooler 06.3014.6045 (please order separately) in
etagere 06.3010.6040, 06.3011.6040, 06.2441.6040 combiNation buffet

Cromargan® / stainless 18/10

Höhe	height	Ø	Ø	
cm	in.	cm	in.	
22,5	8¾	26	10¼	06.6521.6040



**Tablett, rund
CLASSIC**

serving tray, round
plateau de service, rond
bandeja, redonda
vassoio, rotondo

∅	∅
cm	in.
42,5	16 ³ / ₄

Cromargan®	versilbert
stainless 18/10	silverplated
06.7846.6040	19.7846.6440



**Tablett, rund
CLASSIC**

serving tray, round
plateau de service, rond
bandeja, redonda
vassoio, rotondo

∅	∅
cm	in.
29,5	11 ¹ / ₂
35	13 ³ / ₄
41,7	16 ¹ / ₂
60	23 ¹ / ₂

Cromargan®	versilbert
stainless 18/10	silverplated
06.7260.6040	19.7260.6440
06.7261.6040	19.7261.6440
06.7262.6040	19.7262.6440
06.7263.6040	



**Tablett, rund
BISTRO**

serving tray, round
plateau de service, rond
bandeja, redonda
vassoio, rotondo

stapelbar /
stackable

Cromargan® / stainless 18/10

∅	∅
cm	in.
42,6	16 ³ / ₄

06.7679.6040



**Tablett, oval
CLASSIC**

serving tray, oval
plateau de service, ovale
bandeja, oval
vassoio, ovale

Größe	size
cm	in.
51,6 x 39,3	20 ¹ / ₄ x 15 ¹ / ₂

Cromargan®	versilbert
stainless 18/10	silverplated
06.7845.6040	19.7845.6440



Tablett, oval

serving tray, oval
 plateau de service, ovale
 bandeja, oval
 vassoio, ovale

Cromargan® / stainless 18/10

Größe	size
cm	in.
51,6 x 39,3	20 ¹ / ₄ x 15 ¹ / ₂
59,5 x 46,7	23 ¹ / ₂ x 18 ¹ / ₂

06.7265.6040
 06.7266.6040



Kaffeetablett PURE

serving tray
 plateau de service
 bandeja
 vassoio

stapelbar, oval /
 stackable, oval

Cromargan® / stainless 18/10

Größe	size
cm	in.
27 x 17	10 ¹ / ₂ x 6 ³ / ₄

06.7550.6040



Tablett, oval PURE

serving tray, oval
 plateau de service, ovale
 bandeja, oval
 vassoio, ovale

passend für Toastständer 06.4280.6040 und Porzellanschale 3geteilt
 60.3538.9990 /
 suitable for toast rack 06.4280.6040 and for porcelain bowl 3pcs.
 60.3538.9990

stapelbar /
 stackable

Cromargan® / stainless 18/10

Größe	size
cm	in.
24,5 x 12	9 ¹ / ₂ x 4 ³ / ₄

06.7551.6040



**Tablett
URBAN**

tray
plateau
bandeja
vassoio

Cromargan® / stainless 18/10

Größe	size
cm	in.
23 x 10,7	8 x 4 ¹ / ₄

55.0058.6045



Tablett, oval

serving tray, oval
plateau de service, ovale
bandeja, oval
vassoio, ovale

Größe	size
cm	in.
22 x 15,5	8 ³ / ₄ x 6
27 x 20	10 ¹ / ₂ x 8
29 x 22,5	11 ¹ / ₂ x 8 ³ / ₄

Cromargan®	versilbert
stainless 18/10	silverplated
06.7540.6040	19.7540.6440
06.7542.6040	19.7542.6440
06.7543.6040	19.7543.6440



**Tablett, oval
CLASSIC**

serving tray, oval
plateau de service, ovale
bandeja, oval
vassoio, ovale

Cromargan® / stainless 18/10

Größe	size
cm	in.
51,6 x 39,3	20 ¹ / ₄ x 15 ¹ / ₂
59,5 x 46,7	23 ¹ / ₂ x 18 ¹ / ₂

06.7835.6040
06.7836.6040

Maße ohne Griffe / measures without handles



**Tablett, oval
BISTRO**

serving tray, oval
plateau de service, ovale
bandeja, oval
vassoio, ovale

stapelbar /
stackable

Cromargan® / stainless 18/10

Größe	size
cm	in.
51,6 x 39	20 ¹ / ₄ x 15 ¹ / ₄

06.7681.6040



**Tablett, oval
NEUTRAL**

serving tray, oval
plateau de service, ovale
bandeja, oval
vassoio, ovale

Cromargan® / stainless 18/10

Größe	size
cm	in.
51,6 x 39	20 ³ / ₄ x 15 ¹ / ₄

06.8442.6040

Maße ohne Griffe / measures without handles



**Tablett, Gastronorm,
RESIDENCE**

serving tray, Gastronorm
plateau de service, Gastronorm
bandeja, Gastronorm
vassoio, Gastronorm

Rand dekoriert, rechteckig /
rim decorated, rectangular

Cromargan® / stainless 18/10

	Größe cm	size in.	
GN 1 ¹ / ₁ *	53 x 32,5	20 ³ / ₄ x 12 ³ / ₄	06.7744.6040
GN 2 ¹ / ₁	65 x 53	25 ¹ / ₂ x 20 ³ / ₄	06.7745.6040

* Passend auf alle GN 1¹/₁ Rahmen von combiNation buffet /
fitting on all GN 1¹/₁ frames of combiNation buffet



**Tablett, Gastronorm,
CLASSIC**

serving tray, Gastronorm
plateau de service, Gastronorm
bandeja, Gastronorm
vassoio, Gastronorm

Passend auf alle GN 1¹/₁ Rahmen von combiNation buffet /
fitting on all GN 1¹/₁ frames of combiNation buffet

GN 1¹/₁, rechteckig /
GN 1¹/₁, rectangular

Größe	size	Cromargan®	versilbert
cm	in.	stainless 18/10	silverplated
53 x 32,5	20 ³ / ₄ x 12 ³ / ₄	06.7849.6040	19.7849.6440



Tablett, Gastronorm

serving tray, Gastronorm
 plateau de service, Gastronorm
 bandeja, Gastronorm
 vassoio, Gastronorm

rechteckig /
 rectangular

Cromargan® / stainless 18/10

	Größe cm	size in.	
GN 1/2*	32,5 x 26,5	12 ³ / ₄ x 10 ¹ / ₂	06.7658.6040
GN 1/1**	53 x 32,5	20 ³ / ₄ x 12 ³ / ₄	06.7660.6040
GN 2/1	65 x 53	25 ¹ / ₂ x 20 ³ / ₄	06.7661.6040

* Passend auf alle GN 1/2 Rahmen / fitting on all GN 1/2 frames

** Passend auf alle GN 1/1 Rahmen / fitting on all GN 1/1 frames



**Tablett Gastronorm
 CLASSIC**

serving tray Gastronorm
 plateau de service Gastronorm
 bandeja Gastronorm
 vassoio Gastronorm

rechteckig /
 rectangular

Cromargan® / stainless 18/10

	Größe cm	size in.	
GN 1/1	53 x 32,5	20 ³ / ₄ x 12 ³ / ₄	06.7838.6040
GN 2/1	65 x 53	25 ¹ / ₂ x 20 ³ / ₄	06.7839.6040

Maße ohne Griffe / measures without handles



**Tablett Gastronorm
 BISTRO**

serving tray Gastronorm
 plateau de service Gastronorm
 bandeja Gastronorm
 vassoio Gastronorm

GN 1/1, stapelbar, rechteckig /
 GN 1/1, stackable, rectangular

Cromargan® / stainless 18/10

Größe cm	size in.	
53 x 32,5	20 ³ / ₄ x 12 ³ / ₄	06.7680.6040



**Tablett Gastronorm
NEUTRAL**

serving tray Gastronorm
plateau de service Gastronorm
bandeja Gastronorm
vassoio Gastronorm

rechteckig /
rectangular

Cromargan® / stainless 18/10

	Größe cm	size in.	
GN 1/1	53 x 32,5	20 ³ / ₄ x 12 ³ / ₄	06.8440.6040
GN 2/1	65 x 53	25 ¹ / ₂ x 20 ³ / ₄	06.8441.6040

Maße ohne Griffe / measures without handles



Tablett, rechteckig, Gastronorm

serving tray, rectangular, Gastronorm
plateau de service, rectangulaire, Gastronorm
bandeja, rectangular, Gastronorm
vassoio, rettangolare, Gastronorm

Passend auf alle GN 1/1 Rahmen von combiNation buffet /
fitting on all GN 1/1 frames of combiNation buffet

GN 1/1, stapelbar, rechteckig, schnittfest, spülmaschinenfest /
GN 1/1, stackable, rectangular, resistant against cutting, dishwasher-safe

Kunststoff, Cromargan® - Griffe /
high quality plastic, handle stainless 18/10

Größe cm	size in.	
53 x 32,5	20 ³ / ₄ x 12 ³ / ₄	06.7683.6040



**Tablett, rechteckig
CLASSIC**

serving tray, rectangular
plateau de service, rectangulaire
bandeja, rectangular
vassoio, rettangolare

Größe cm	size in.	Cromargan® stainless 18/10	versilbert silverplated
53,8 x 42	21 ¹ / ₄ x 16 ¹ / ₂	06.7848.6040	19.7848.6440



Tablett, rechteckig

serving tray, rectangular
plateau de service, rectangulaire
bandeja, rectangular
vassoio, rettangolare

Größe cm	size in.	Cromargan® stainless 18/10	versilbert silverplated
40,1 x 29	15 ³ / ₄ x 11 ¹ / ₂	06.7269.6040	
52,6 x 40,8	20 ³ / ₄ x 16	06.7271.6040	19.7271.6440
77,2 x 50,7	30 ¹ / ₂ x 20	06.7272.6040	

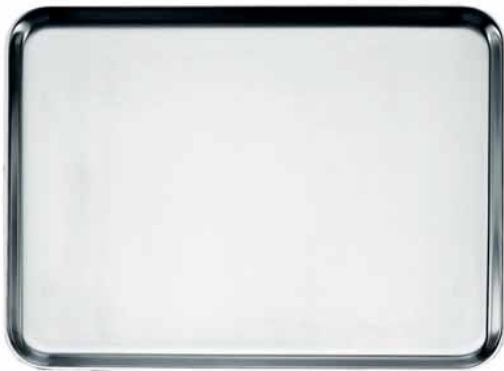

Tablett, rechteckig

serving tray, rectangular
 plateau de service, rectangulaire
 bandeja, rectangular
 vassoio, rettangolare

Cromargan® / stainless 18/10

Größe	size
cm	in.
24 x 18	9 ¹ / ₂ x 7
28,5 x 21	11 ¹ / ₄ x 8 ¹ / ₄
33 x 26	13 x 10 ¹ / ₄
42,5 x 31,5	16 ³ / ₄ x 12 ¹ / ₂
50,5 x 37	20 x 14 ¹ / ₂

06.7584.6040
06.7585.6040
06.7586.6040
06.7588.6040
06.7589.6040



Tablett, rechteckig CLASSIC

serving tray, rectangular
 plateau de service, rectangulaire
 bandeja, rectangular
 vassoio, rettangolare

Cromargan® / stainless 18/10

Größe	size
cm	in.
52,6 x 40,8	20 ³ / ₄ x 16
77,2 x 50,7	30 ¹ / ₂ x 20

06.7841.6040
06.7842.6040

Maße ohne Griffe / measures without handles



Tablett, rechteckig NEUTRAL

serving tray, rectangular
 plateau de service, rectangulaire
 bandeja, rectangular
 vassoio, rettangolare

Cromargan® / stainless 18/10

Größe	size
cm	in.
52,6 x 40,8	20 ³ / ₄ x 16

06.8444.6040

Maße ohne Griffe / measures without handles



Lachsbrett

salmon board
 planche à saumon
 salmonera
 vassoio per salmone

Kopf und Schwanz verchromt, Brett Naturholz /
 head and tale chrome plated, wooden board

Größe	size
cm	in.
92 x 20	36 ¹ / ₄ x 8

19.9999.4783



Käseglocke

NEUTRAL

cheese dish
cloche à fromage
quesera
porta formaggio

Holzinsatz Buche / beech wooden insert

	Ø cm	Ø in.	
passt in Tablett 7262 / fitting tray 7262	36,7	14 ¹ / ₂	60.3103.9990
passt in Tablett 7263, 7833 / fitting tray 7263, 7833	55	21 ³ / ₄	60.3106.9990

Plexiglashaube / plastic cover

	Ø cm	Ø in.	
passt zu Einsatz 3103 / fitting insert 3103	34	13 ¹ / ₂	06.2864.6040
passt zu Einsatz 3106 / fitting insert 3106	50	19 ³ / ₄	06.2865.6040



Abdeckhaube

cover for trays
cloche pour plateaux
campana para bandejas
coperchio adatto per vassoio

für Tablett GN 1/1 ohne Griffe /
for trays GN 1/1 without handles

Kunststoff glasklar, Griff verchromt /
high quality plastic, handle chrome plated

Höhe cm	height in.	Größe cm	size in.	
14,5	5 ³ / ₄	55,5 x 35	22 ³ / ₄ x 13 ³ / ₄	06.2939.6040



Abdeckhaube

cover for trays
cloche pour plateaux
campana para bandejas
coperchio adatto per vassoio

mit 2 seitlichen Eingriffen, passend für Tablett GN 1/1 ohne Griffe /
with two side openings, fitting for trays GN 1/1 without handles

Kunststoff glasklar, Griff verchromt /
high quality plastic, handle chrome plated

Höhe cm	height in.	Größe cm	size in.	
14,5	5 ³ / ₄	55,5 x 35	21 ³ / ₄ x 13 ³ / ₄	06.2937.6040



**Tortenplatte
CLASSIC**

cake plate
plat à tarte
plato tarta
piatto da torta

Höhe	height	Ø	Ø	Cromargan®	versilbert
cm	in.	cm	in.	stainless 18/10	silverplated
11,8	4 1/2	32	12 1/2	06.4286.6040	19.4286.6440



Kuchen-/Tortenplatte

cake plate
plat à tarte
plato tarta
piatto da torta

Cromargan® / stainless 18/10

Höhe	height	Ø	Ø	
cm	in.	cm	in.	
14,5	5 3/4	35,5	14	06.4274.6040



Kuchen-/Tortenplatte

cake plate
plat à tarte
plato tarta
piatto da torta

Cromargan®, matt / stainless 18/10, satin finished

Höhe	height	Ø	Ø	
cm	in.	cm	in.	
3	1 1/4	20	8	06.4277.6030
3	1 1/4	32	12 1/2	06.4300.6030

Buffetkegel buffet cone

... für stehende Ovationen!
... for standing ovations!

Variationsmöglichkeiten variation options

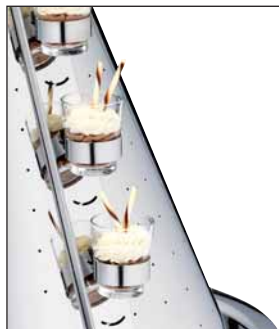

Schiene mit Spangen
und Gläsern ...
slotted rail with glass
hooks and glasses...



... und mit **happy spoons**
... and with **happy spoons**



Komplettansicht
Komplettansicht



... und mit **Dekorations-Picker**
... and with **cocktail sticks**



Produktvorteile

Einfach die Spitze jeden Buffets

Oft entscheiden bei einem neuen Gericht nicht nur die einzelnen Komponenten sondern auch die Kombination.

So ist auch die Kombinierbarkeit des WMF Buffetkegels ein zentraler Punkt für dessen Erfolgsstory. Tausende Möglichkeiten für immer das gleiche Ziel: Ihren Erfolg.

Immer eine kleine Sensation

Die Buffetkegel von WMF sorgen zuverlässig für den "Aha"-Effekt. Einfach und schnell zu dekorieren sowie »lecker« anzusehen, damit sind sie das Highlight auf jedem Buffet.

Kompakt

Die kompakte Bauweise spart viel vom sowieso knapp bemessenen Platz auf jedem Buffet.

Material und Verarbeitung

Das hochwertige Cromargan® ist absolut geruchsneutral, spülmaschinen- und lebensmittelgeeignet.

Vielseitig und wertig

Sämtliche Zubehörteile lassen sich einfach und schnell ein- und umbauen. Der schöne Gesamteindruck bleibt.

Advantages of the products

The highlight of every buffet

When presenting a new dish, it is very often the combination of components that proves decisive, rather than the individual components. The flexibility of the WMF Buffet cone is also a key element of its success story. Thousands of possibilities all serving the same purpose: your successful performance.

Always create a small sensation

Buffet cones from WMF regularly surprise. Quickly and easily garnished to look really appetising, they are the absolute highlight of every buffet.

Compact

The compact construction saves lots of precious space on any buffet.

Material and finish

The high-grade Cromargan® is totally odourless, dish washer safe and food safe.

Versatile and high grade

All accessories fit easily and quickly together. The aesthetic memory will linger.



Buffet-Kegel-Set, klein

buffet cone set, small
 set cône de buffet, petit mod.
 set cono buffet completo, pequeño
 set portastuzzichini conico per buffet, piccolo

drehbar, für 180 Spieße, bestehend aus: Buffet-Kegel klein, Drehtablett klein und Einsatzbehälter /
 turnable, holds 180 cocktail sticks, consisting of: buffet cone small, revolving tray small and insert

Cromargan® / stainless 18/10

Höhe	height	Ø	Ø	
cm	in.	cm	in.	
29,5	11 1/2	42,5	16 3/4	06.2471.6040

Ersatzteil / spare part:
 Einsatzbehälter / insert 06.2470.6044
 Buffet-Kegel, klein / buffet cone, small 06.2471.6042
 Drehtablett, klein / revolving tray, small 06.2471.6045



Buffet-Kegel-Set, groß

buffet cone set, large
 set cône de buffet, grand mod.
 set cono buffet, grande
 set cono buffet, grande

drehbar, für 330 Spieße, bestehend aus: Buffet-Kegel groß, Drehtablett groß und Einsatzbehälter /
 turnable, holds 330 cocktail sticks, consisting of: buffet cone large, revolving tray large and insert

Cromargan® / stainless 18/10

Höhe	height	Ø	Ø	
cm	in.	cm	in.	
51	20 1/2	59,5	22	06.2470.6040

Ersatzteil / spare part:
 Buffet-Kegel, groß / buffet cone, large 06.2470.6042
 Drehtablett, groß / revolving tray, large 06.2470.6045
 Einsatzbehälter / insert 06.2470.6044



Dekorations-Picker

cocktail sticks
 brochettes cocktail
 pincho de cocktail
 spiedini da cocktail

Packung 1.000 St., zum Bestücken mit Food für die Buffet-Kegel-Sets 06.2470.6040, 06.2471.6040 und das Tischkegel-Set 06.2474.6040 /
 package 1.000 pcs., to spit on with food for the buffet cones 06.2471.6040, 06.2470.6040 and the table cone set 06.2474.6040

Holz / wood

Länge	length	Ø	Ø	
cm	in.	cm	in.	
10	4	0,2	1/6	19.9999.8695



Buffetkegel-Schiene

slotted rail for buffet cones
 porte-coupelle pour sets cône de table
 portacubiertos para cono mediano
 barra per posate sets cono da tavola

Cromargan® / stainless 18/10

Buffetkegel-Schiene, kurz / slotted rail, short for buffet cones

mit Ausschnitten für 5 Happy Spoons und für 3 Spangen für Gläser S oder Tassen S KaffeeKultur, passend zu Buffetkegel klein. (Max. 8 Schienen) /

with slots for 5 happy spoons and for 3 glass hooks for glasses S or cups S CoffeeCulture, fitting for buffet cone small. (Max. 8 rails)

Größe	size
cm	in.
28,9 x 4,5	11 ¹ / ₄ x 1 ³ / ₄

06.0481.6040



Buffetkegel-Schiene, lang / slotted rail, long for buffet cones

mit Ausschnitten für 9 Happy Spoons und 5 Spangen für Gläser S oder Tassen S KaffeeKultur, passend zu Buffetkegel groß. (Max. 8 Schienen) /

Größe	size
cm	in.
51,9 x 4,5	20 ¹ / ₂ x 1 ³ / ₄

06.0482.6040



Happy Spoon

happy spoon
 happy spoon
 happy spoon
 happy spoon

in Menue- und Vorspeisengröße! /
 in size table and dessert spoon!

Cromargan® / stainless 18/10

	Länge	length	
	cm	in.	
Happy Spoon	12,5	5	12.8993.6040
Happy Spoon S	11,5	4 ¹ / ₂	12.8345.6040



Spangen für Gläser

glass hooks
 agrafes pour verres
 ganchos para vasos
 fermagli per bicchieri

zum Einhängen in die Buffetkegel-Schienen. Fixiert die Gläser S oder Tassen S von KaffeeKultur oder Gläser mit Sitz-Ø max. 4,4 cm /
 to hinge in the rails for buffet cones. Fixes glasses S or cups S of CoffeeCulture or glasses with diameter max. 4,4 cm at their seating

Cromargan® / stainless 18/10

Ø	Ø
cm	in.
5	2

06.0487.6040



**Porzellantasse S
KAFFEEKULTUR**

porcelain cup S
tasse en porcelaine S
taza de porcelana S
tazzina di porcellana S

Porzellan / porcelain

Höhe cm	height in.	Inhalt Ltr.	cap. oz.
7,4	3	0,09	3,2

60.2508.9990



Glas S

glass S
verre S
vaso S
bicchiere S

Glas / glass

Höhe cm	height in.	Inhalt Ltr.	cap. oz.
7,4	3	0,09	3,2

60.2506.9990



Happy Spoon Gestell

Happy Spoon stand
présentoir Happy Spoon
soporte Happy Spoon
porta Happy Spoon

für 8 Happy Spoons /
for 8 happy spoons

Cromargan® / stainless 18/10

Größe cm	size in.
13 x 11 x 26,25	5 x 4 ¹ / ₄ x 10 ¹ / ₄

06.8344.6040

Zubehör / accessory:

Happy Spoon S	12.8345.6040
Happy Spoon	12.8993.6040

**Früchtekorb**

fruit basket
panier à fruits
frutero
fruttiera

passend in Etagère 06.3010.6040, 06.3011.6040, 06.2441.6040
combiNation buffet nur in Verbindung mit Kühlbehälter 06.3014.6045
(bitte separat bestellen) /
fitting together with cooler 06.3014.6045 (please order separately) in
etagere 06.3010.6040, 06.3011.6040, 06.2441.6040 combiNation buffet

Cromargan® / stainless 18/10

Höhe	height	Ø	Ø
cm	in.	cm	in.
22,5	8 ³ / ₄	26	10 ¹ / ₄

06.6521.6040

**Brotkorb, rund
OLE PALSBY**

bread-basket, round
panier à pain, rond
cesta del pan, redonda
cestino per il pane, rotondo

Cromargan® / stainless 18/10

Ø	Ø
cm	in.
18	7 ¹ / ₂
26	10 ¹ / ₄

06.6575.6040

06.6514.6040

**Brotkorb
PURE**

bowl for bread
panier à pain
panera
portapane

stapelbar /
stackable

Cromargan® teilmattiert / stainless 18/10 partly satin finished

Größe	size
cm	in.
25 x 14 x 5	9 ³ / ₄ x 5 ¹ / ₂ x 2

06.6535.6040

**Brotkorb**

bread-basket
panier à pain
cesta del pan
cestino per il pane

oval /
oval

versilbert / silverplated

Größe	size
cm	in.
22,3 x 16,3 x 6	8 ³ / ₄ x 6 ¹ / ₂ x 2 ¹ / ₄
27 x 19 x 6,5	10 ³ / ₄ x 7 ¹ / ₂ x 2 ¹ / ₂

19.6319.7030

19.6329.6440





Brottschale

bowl for bread
panier à pain
panera
portapane

Größe	size
cm	in.
28 x 17	11 x 6 ³ / ₄

Cromargan®	versilbert
stainless 18/10	silverplated
06.6380.6040	19.6380.6440



Brottschale

bowl for bread
panier à pain
panera
portapane

oval, Durchbruchdekor /
oval, stencil pattern

Cromargan® / stainless 18/10

Größe	size
cm	in.
20 x 15	8 x 6

06.6571.6040



**Universalschale
PURE**

universal dish
coupe universelle
recipiente universal
ciotola universale

stapelbar /
stackable

Cromargan® teilmattiert / stainless 18/10 partly satin finished

Höhe	height	Ø Schale	dish Ø
cm	in.	cm	in.
5,5	2 ¹ / ₄	12	4 ³ / ₄

06.1799.6040



Universalschale

finger bowl
coupe universelle
recipiente universal
ciotola universale

Cromargan® / stainless 18/10

Inhalt	cap.	Ø Schale	dish Ø
Ltr.	oz.	cm	in.
0,2	7	12	4 ³ / ₄

06.1849.6040



Cocktail- und Dessertschale CLASSIC

cocktail and dessert dish
coupe à cocktail et dessert
copa cóctel y postre
coppa per cocktail e frutta

Höhe	height	Ø	Ø	Cromargan®	versilbert
cm	in.	cm	in.	stainless 18/10	silverplated
13,5	5 1/4	11,4	4 1/2	06.1878.6040	19.1878.6440



Eisschale

ice cream cup
coupe à glace
recipiente universal
coppa gelato

Cromargan® / stainless 18/10

Höhe	height	Inhalt	cap.	Ø	Ø	
cm	in.	Ltr.	oz.	cm	in.	
4,5	1 3/4	0,11	2,9	9,5	3 3/4	06.1830.6040



Obstschale BISTRO

fruit stand
coupe à fruits
frutero
alzata per frutta

Cromargan®, Glas / stainless 18/10, glass

Höhe	height	Ø Schale	Ø bowl	
cm	in.	cm	in.	
16	6 1/4	38	15	06.6895.6040

Ersatzteil / spare part:

Glasschale mittel / glass plate medium	19.9999.8644
--	--------------



Obstschale CLASSIC

fruit bowl
coupe à fruits
frutero
alzata per frutta

Höhe	height	Ø	Ø	Cromargan®	versilbert
cm	in.	cm	in.	stainless 18/10	silverplated
14	5 1/2	23	9	06.6483.6040	19.6483.6440



Früchtekorb

fruit basket
corbeille de fruits
cesta de frutas
cesto di frutta

Cromargan® / stainless 18/10

Größe	size
cm	in.
36 x 24 x 5	14 ¹ / ₄ x 9 ¹ / ₂ x 2

06.8237.6040



Obstschale

fruit bowl
coupe à fruits
frutero
alzata per frutta

oval /
oval

Cromargan® / stainless 18/10

Größe	size
cm	in.
22 x 27 x 13,5	8 ³ / ₄ x 10 ³ / ₄ x 5 ¹ / ₄

06.8238.6040



Obstschale

fruit bowl
coupe à fruits
frutero
alzata per frutta

Cromargan® / stainless 18/10

Größe	size
cm	in.
22,5 x 22,5 x 7,2	8 ³ / ₄ x 8 ³ / ₄ x 2 ³ / ₄
34,5 x 35 x 11	13 ¹ / ₂ x 13 ³ / ₄ x 4 ¹ / ₄

06.8236.6040

06.8235.6040

BAR & SMOKE



Alles für den
professionellen
Sommelier und
Barfachmann
All for the professional
sommelier and bartender



Cocktailshaker

cocktail shaker
shaker
coctelera
shaker

Cromargan® / stainless 18/10

Inhalt	cap.
Ltr.	oz.
0,5	17,5

06.1371.6030



Boston Shaker, Metallbecher 18/10 mit Rührglas

boston shaker, metal 18/10 with mixing glass
shaker boston, acier 18/10 et verre mélanger
coctelera boston, metal 18/10 con interior de cristal
boston shaker, inox 18/10 e vetro

Cromargan® / stainless 18/10

Inhalt	cap.	Ø	Ø
Ltr.	oz.	cm	in.
0,4	14	9	3 1/2
0,27	9,5	8	3 1/4

06.1358.6040

06.1357.6040

Ersatzteil / spare part:

Ersatzglas groß / spare glass large

19.9999.8646

Ersatzglas klein / spare glass small

19.9999.8649



Rührglas

mixing glass
agitateur pour verre
vaso mezclador
mixer

Höhe	height	Inhalt	cap.	Ø	Ø
cm	in.	Ltr.	oz.	cm	in.
18	7	0,73	25,6	9	3 1/2

19.9999.8647



Messbecher, einteilig mit Steg

jigger, one piece with handle
measure, un pièce avec poignées
medidor, una pieza, con mango
misurino, ad uno scomparto, con manico

Cromargan® / stainless 18/10

Inhalt	cap.
Ltr.	oz.
0,02	0,7

06.5165.6040



Messbecher, zweiteilig

jigger, double
 mesure, double
 medidor, doble
 misurino, bifronte

Cromargan® / stainless 18/10

Inhalt	cap.
Ltr.	oz.
0,02 / 0,04	0,7 / 1,4

06.5166.6040



Cocktailsieb

cocktail strainer
 passoire à cocktail bar
 colador de cocktail
 colino per cocktail

Cromargan® / stainless 18/10

Länge	length
cm	in.
17,5	7

06.1364.6040



Bitterflasche

bitter bottle
 flacon à angostura
 botella para bitter
 spruzzamaro

Kristall mit Spritzkork / crystal with squirt-cork

Inhalt	cap.
Ltr.	oz.
0,2	7
0,3	10,5

06.7172.6040

06.7171.6040

Ersatzteil / spare part:

Ersatzflasche klein / spare bottle small	19.9999.8648
Ersatzflasche groß / spare bottle large	19.9999.8605



Spritzkork

squirt-cork
 bouchon-verseur
 tapón
 tappo a spruzzo

Ausgießer verchromt / pourer chromeplated

06.4051.6040



**Universalschale
PURE**

universal dish
coupe universelle
recipiente universal
ciotola universale

stapelbar /
stackable

Cromargan® teilmattiert / stainless 18/10 partly satin finished

Höhe	height	Ø Schale	dish Ø	
cm	in.	cm	in.	
5,5	2 ¹ / ₄	12	4 ³ / ₄	06.1799.6040

Universalschale

finger bowl
coupe universelle
recipiente universal
ciotola universale

Cromargan® / stainless 18/10

Inhalt	cap.	Ø Schale	dish Ø	
Ltr.	oz.	cm	in.	
0,2	7	12	4 ³ / ₄	06.1849.6040



**Relish-Pickles-Gestell
NEUTRAL**

relish or condiment server
service à relish
porta aperitivos
portasalatini / olive

Cromargan® / stainless 18/10

Höhe	height	Ø Schale	dish Ø	
cm	in.	cm	in.	
13	5	8	3 ¹ / ₄	06.2829.6040



**Relish-Pickles-Gestell
CLASSIC**

relish or condiment server
service à relish
porta aperitivos
portasalatini / olive

Höhe	height	Ø Schale	dish Ø	Cromargan®	versilbert
cm	in.	cm	in.	stainless 18/10	silverplated
19,5	7 ³ / ₄	8	3 ¹ / ₄	06.2846.6040	19.2846.6440





Bargestell, 3teilig

bar-relish dish, 3 pieces
service à relish, 3 parties
soporte de bar, 3 recipientes
set per bar, 3 pezzi

drehbar /
turnable

Cromargan® / stainless 18/10

Höhe cm	height in.	Ø Schale cm	dish Ø in.
19	7½	8	3¼

06.2831.6040

Ersatzteil / spare part:
Glasschale / glass dish

19.9999.8616



Sektflaschenverschluss

champagne bottle sealer
bouchon à champagne
tapón botellas champán
tappo per spumante

verchromt / chromeplated

Länge cm	length in.	Ø cm	Ø in.
9	3½	4	1½

06.4081.6040



Eiszange

ice tongs
pince à glace
pinza hielo
pinza per ghiaccio

Länge cm	length in.
17,3	6¾

Cromargan® versilbert
stainless 18/10 silverplated
12.8307.6040 10.8307.6060



Eiszange

ice tongs
pince à glace
pinza hielo
pinza per ghiaccio

Cromargan® / stainless 18/10

Länge cm	length in.
20	8

12.9009.6040



Dekorierzange

decoration tongs
 pince à décorer
 pinza para decorar
 pinza per decorare

Cromargan® / stainless 18/10

Länge	length
cm	in.
11	4 1/4

12.9010.6040



Roheisschaufel

ice shovel
 pelle à glace
 pala hielo
 paletta per ghiaccio

Cromargan® / stainless 18/10

Länge	length
cm	in.
18	7

12.8997.6030



Barlöffel

bar spoon
 cuiller à soda
 cuchara bar
 cucchiaio per bar

Cromargan® / stainless 18/10

Länge	length
cm	in.
26,5	10 1/2

12.9000.6040



Barlöffel, gedreht

bar spoon, twisted
 cuiller à soda, torsadée
 cuchara gitador bar
 cucchiaio per bar, ritorto

Cromargan® / stainless 18/10

Länge	length
cm	in.
27	10 1/2

12.9004.6040

Barquirl

twirling stick
cuillère de bar
batidor de bar
miscelatore



Cromargan® / stainless 18/10

Länge	length
cm	in.
22	8 ³ / ₄

12.8998.6040

Barmesser

bar knife
couteau de bar
cuchillo bar
coltello per bar



Klingenstahl mit Wellenschliff / monobloc with serrated edge

Länge	length	Klingenlänge	length of blade
cm	in.	cm	in.
23	9	11,5	4 ¹ / ₂

12.9003.6040

Kapselheber

bottle opener
décapsuleur
abrebotellas
levacapsule



Cromargan® / stainless 18/10

Länge	length
cm	in.
16	6 ¹ / ₄

12.9001.6040

Barzange

bar tongs
pince de bar
pinzas bar
pinza per bar



vernickelt / nickelplated

Länge	length
cm	in.
17	6 ³ / ₄

12.9006.6040



Zuckerzange

sugar tongs
 pince à sucre
 pinza de azucar
 pinza per zucchero

Länge	length
cm	in.
10,7	4 1/4

Cromargan®	versilbert
stainless 18/10	silverplated
12.8342.6040	10.8342.6060



Stößel

tamping tool
 pilon
 mazo de mortero
 pestello

Holz / wood

Länge	length
cm	in.
19,5	7 3/4

12.9005.9990



Kellnermesser

waiter's knife
 couteau à sommelier
 abridor múltiple-camareros
 coltello per bar

Cromargan® mattiert / stainless 18/10, satin finished

Länge	length
cm	in.
13,4	5 1/4

12.8009.6030



Dosenöffner

can opener
 ouvre-boîte
 abrelatas
 abriscatole

ganz Metall. Hinterlässt keine scharfen Kanten am Dosendeckel, Deckel kann wieder aufgesetzt werden. /
 all metal. Does not leave sharp edges on the can lid - lid can be replaced on can.

Cromargan® / stainless 18/10

Länge	length
cm	in.
20	8

18.7319.6040



Korkenzieher

cork-screw
tire-bouchon
sacacorchos
cavatappi

Cromargan® / stainless 18/10

Länge	length
cm	in.
17,5	7

18.8252.6019



Zitronenpresse, 6er Set

lemon/orange squeezer, set of 6
presse-citron, en 6 parties
exprimidor para limones, 6 piezas
spremilimone, a 6 vaschette

Cromargan® mattiert / stainless 18/10, satin finished

06.8221.6030



Eisgefäß CLASSIC

ice bucket
seau à glace
cubo hielo
secchiello da ghiaccio

mit Eiseinsatz /
with grid

Höhe	height	Inhalt	cap.	Cromargan®	versilbert
cm	in.	Ltr.	oz.	stainless 18/10	silverplated
12	4 ³ / ₄	1,5	52,5	06.1761.6040	19.1761.6440



Eisgefäß URBAN

ice bucket
seau à glace
cubo hielo
secchiello da ghiaccio

doppelwandig /
double wall

Cromargan® / stainless 18/10

Höhe	height	Ø	Ø
cm	in.	cm	in.
15	6	14	5 ¹ / ₂

55.0065.6040



**Eisgefäß
NEUTRAL**

ice bucket
seau à glace
cubo hielo
secchiello da ghiaccio

Cromargan® / stainless 18/10

Höhe	height	Inhalt	cap.
cm	in.	Ltr.	oz.
12	4¾	1,5	52,5

06.1760.6040



**Eisgefäß
PURE**

ice bucket
seau à glace
cubo hielo
secchiello da ghiaccio

Cromargan® teilmattiert / stainless 18/10 partly satin finished

Höhe	height	Inhalt	cap.
cm	in.	Ltr.	oz.
15	6	1,5	52,5

06.1767.6040



Eisgefäß

ice bucket
seau à glace
cubo hielo
secchiello da ghiaccio

doppelwandig /
double wall

Cromargan® / stainless 18/10

Höhe	height	Inhalt	cap.	Ø	Ø
cm	in.	Ltr.	oz.	cm	in.
15	6	0,7	23,66	12,5	5

55.0035.6040



**Ascher
PURE**

ash tray
cendrier
cenicero
posacenere

stapelbar /
stackable

Cromargan®, teilmattiert /
stainless 18/10, partly satin finished

Höhe	height	Ø	Ø
cm	in.	cm	in.
5	2	14	5½

06.5552.6040

**Zigarrenabschneider**

cigar cutter
coupe-cigares
cortapuros
spuntasigari

Edelstahl 18/10 / stainless 18/10

Länge	length
cm	in.
10	4

55.0094.6040

TRENDS & THEMEN

trends & topics

Hotelzimmer
rooms

Apartments

Glas
glass

Servierwagen
serving trolleys

Küche
kitchen

Kaffeemaschinen
coffee machines

Unser Roomservice – das Angebot an hochwertigen, stilvollen und funktionalen Artikeln, die sich sinnvoll in das Design Ihrer Zimmerausstattung integrieren lassen und Ihren Gast während seines Aufenthaltes begleiten.

Our room service – the range of high quality, stylish and functional products reasonably integrate in the design of your room furniture and accompany your guest during his residence.



Blumenvasen
flower vases



Alle unsere Besteckmodelle im Überblick im Katalogteil I – „BESTECK“
All our models as overview in catalogue part I – „FLATWARE“



Früchteschalen
fruit bowls



Kaffee & Tee
coffee & tea



Petit-Four-Ständer
petit-four-stand



Menagen
cruet stand



Eiseimer
ice bucket



Glas
glass



Doppelwandkannen
Double wall pots

Hotelzimmer
rooms



Apartments liegen weltweit im Trend der Zeit und den Gast erfreut das Gefühl des Vertrauten. Mit unseren funktionalen, designorientierten Artikeln helfen wir, dass es sich ganz wie „Zuhause“ anfühlt.

Apartments meet the current trend worldwide and the guest enjoys the feeling of familiarity. With the aid of our functional, design orientated products it feels like "at home".



Alle unsere Besteckmodelle im Überblick im Katalogteil I - „BESTECK“
All our models as overview in catalogue part I - „FLATWARE“



Seiher
strainer



Gewürzmöhlen
spice mills



Pfannen
pans



Kochtöpfe
cooking pots



Messerserien
kitchen knives



Kinder-Frühstück-Sets
kids breakfast-sets



Glas
glass



Porzellan
porcelain

Apartments



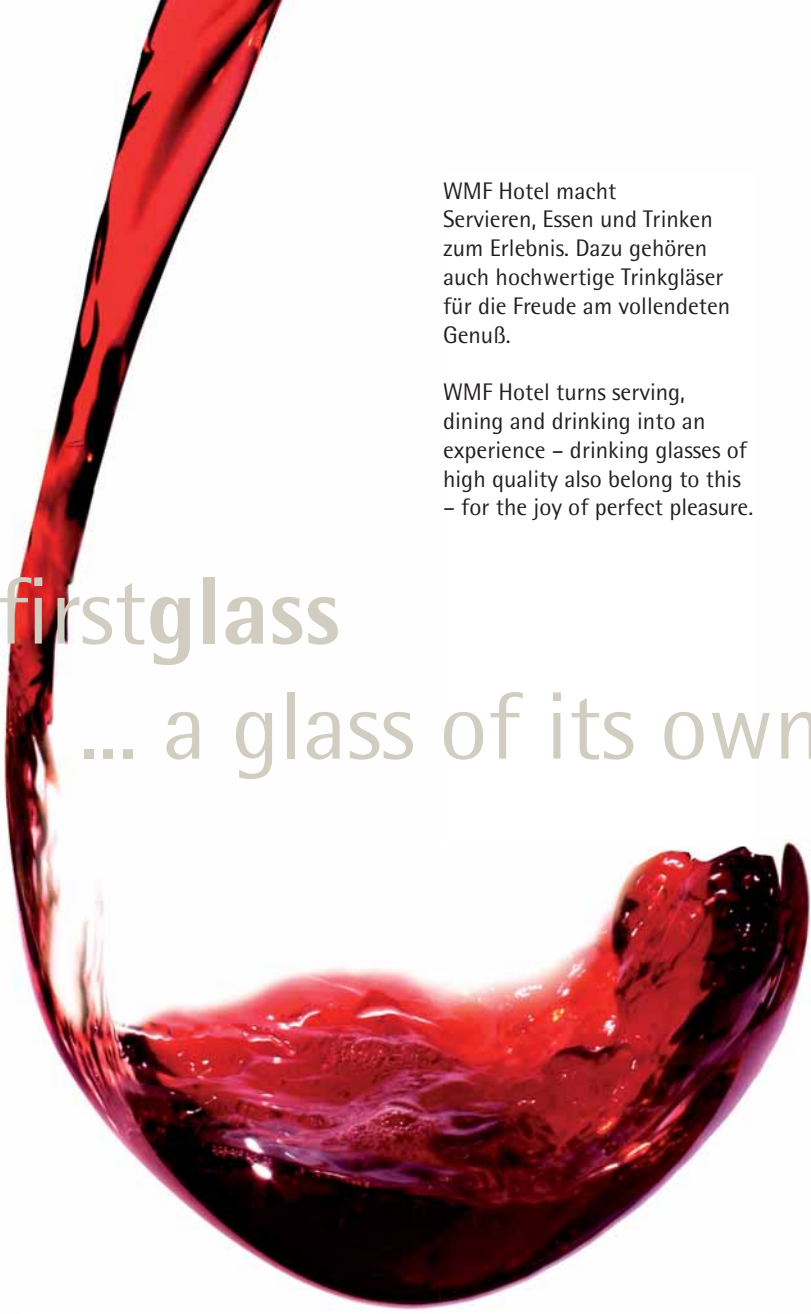

WMF Hotel macht
Servieren, Essen und Trinken
zum Erlebnis. Dazu gehören
auch hochwertige Trinkgläser
für die Freude am vollendeten
Genuß.

WMF Hotel turns serving,
dining and drinking into an
experience – drinking glasses of
high quality also belong to this
– for the joy of perfect pleasure.

WMF firstglass

... a glass of its own

KOMPETENZ:

Kompetenz bedeutet für uns ein bleifreies Kristallglas, dessen Form und Brillanz den Ansprüchen der besten Weine gerecht wird. Eine zweckdienliche Gläserauswahl braucht keinen riesigen Gläserschrank, denn nur Glasformen, die geschmacklich wirklich nachvollziehbare Erlebnisse fördern, machen Sinn.

COMPETENCE:

Competence means to us a lead-free crystal glass whose shape and brilliance meet the requirements of the best wines. A useful selection of glasses does not require a lot of storage as only glass shapes which compliment the wine-tasting experience make sense.

DESIGN:

Wie kein anderes Produkt spielt ein perfektes Glas seine Stärken dadurch aus, ein Präsentationsrahmen für das Besondere zu sein. Nicht die kleinste Unsauberkeit trübt den Blick nach Innen. Nicht der Werkstoff Glas muss wirken, sondern die feinen Spiegelungen und die weichen, fassenden Formen. Im perfekten Zusammenspiel bei WMF firstglass umrahmen sie den Inhalt und bringen ihn glänzend zur Geltung.

DESIGN:

Like no other product a perfect glass highlights its quality by its form. No imperfections spoil the presentation of the wine. Not the material glass must act but the fine reflections and the soft, merging shapes. The composition of WMF firstglass gives shape and form to accentuate its content brilliantly.

Glas
glass



WMF Hotel Servier- und Servicewagen passen einfach überall.
3 Serien im Sortiment (Rondo, Royal, Bistro). Sonderfarben passend zu Ihrer Einrichtung gerne auf Anfrage.
Das ganze Sortiment finden Sie in unserem Teilkatalog WMF Hotel Servier- und Servicewagen.

WMF Hotel serving and service trolleys fit in perfectly, anywhere.
As well as the standard colours shown below, our serving and service trolleys are also available in custom colours according to your requirements or with different leg profiles – to suit your décor.

Qualitätsmerkmale:

Ein Wagen, viele Funktionen. Durch das Wechseln der Einsätze können Sie den Servierwagen der Serien Bistro, Rondo und Royal z. B. in einen Käsewagen etc. verwandeln. So sparen Sie Geld und Platz für viele weitere Wagen.

Quality features:

One trolley, lots of uses. By swapping over the top assemblies you can convert Bistro, Rondo and Royal series serving trolleys into a cheese trolley, for example. A feature which saves you money and the space needed for separate trolleys.



Unempfindlich gegen Feuchtigkeit durch wasserfesten Lack (keine stehende Nässe).
Insensitive to moisture thanks to waterproof varnish (no stagnant water).



Praktische durchdachte Lösungen für den professionellen Einsatz.
Practically thought-out solutions for professional use.



Leicht und leise zu bewegen durch hochwertige (z. T. vergoldete) Vollgummi-Lenkrollen.
Light and easy to move on high-quality (some gold-plated) smooth rubber steering castors.



Hohe Tragkraft von 80 kg.
Big load capacity of 80 kg.



Hohe Stabilität durch verdeckt integrierten Stahlrohrrahmen.
Good stability, frame is reinforced with steel tube inside.



Robuste Rahmen und Kanten aus Massivholz.
Sturdy frame and edges made from solid wood.

Servierwagen
serving trolleys



Der harte Gastronomiealltag ist eine Herausforderung, der wir uns gerne stellen.
Langjährige Erfahrung, ein umfangreiches Profi-Sortiment aus geprüften Materialien in einer hochwertigen Verarbeitung. Dies sind beste Voraussetzungen für unser „Küchenwerkzeug“.

The tough everyday catering trade is a challenge, to which we gladly rise.
Experience of many years, an extensive professional assortment from compliant materials.
These are the best qualifications for our "professional kitchen equipment".



Kochgeschirr
cookware



Kochgeschirr
cookware



Kochgeschirr
cookware



Pfannen
pans



Sauteusen
saucepan



Seiher
sieves



Rührbesen
whisks



Küchenmesser
kitchen knives



Schneidbretter
cutting boards



Küchenkleininventar
kitchen utensils



Küchengeräte
kitchen equipment



Küchengeräte
kitchen equipment

Küche
kitchen



Unter einer Vielzahl verschiedenster Typen und Ausführungen finden Sie genau die Maschine, die den individuellen Anforderungen Ihres Betriebes gerecht wird.

Somewhere in the wide range of different models and versions you will find exactly the right machine to suit the particular requirements of your business.



WMF Kaffeekultur und Qualität made in Germany - weltweit. Tauchen Sie ein in die Welt der Kaffeervielfalt und lassen Sie sich verwöhnen.



WMF coffee culture and quality made in Germany - worldwide. Dip into the world of coffee variety and let your senses be spoiled.



Fordern Sie unverbindlich eines unserer Kaffeemaschinen Prospekte an oder informieren Sie sich über www.wmf-kaffeemaschinen.de
Please, request one of our coffee machine folders or visit www.wmf-kaffeemaschinen.de

Kaffeemaschinen
coffee machines



WMF 8000 S

- Espresso
- Cafe
- Milk Choc
- Foam
- Cappuccino
- Latte Macchiato
- Cafe Latte
- Espr. Macchiato

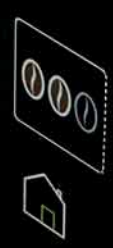

Pflege | Reparatur

maintenance | repair



Material
material

Aufarbeitung & Reparatur
refurbishment & repair

Pflege-Tipps
maintenance

Pflegemittel
cleaning aids

Material:

Die WMF verarbeitet bei Bestecken und Tafelgeräten hauptsächlich korrosions- und säurebeständige Edelstähle (Cromargan®, Chromstahl), wobei Cromargan® teilweise mit einer Silberauflage veredelt wird.



Cromargan®

- Cromargan® ist das eingetragene Warenzeichen der WMF für Edelstahl Rostfrei 18/10
- Edelstahl Rostfrei 18/10 Cromargan® wurde bereits 1927 für die WMF rechtlich geschützt.
- WMF verwendet Cromargan® für die Herstellung von Besteck, Kochgeschirr und vielen anderen Produkten.

Eigenschaften

- auch bei intensivem Gebrauch unverwüstlich und pflegeleicht
- spülmaschinenfest
- temperaturwechselbeständig
- geschmacksneutral und beständig gegen alle Speisesäuren
- absolut hygienisch

Chromstahl

Der von WMF eingesetzte Chromstahl weist eine sehr hohe Beständigkeit sowohl gegenüber Speisesäuren als auch bei der Beanspruchung in Geschirrspülmaschinen auf. Verwendet wird dieser Werkstoff für hochwertige Messerklingen.

Silber

Bei Hotelartikeln wird Silber als Oberflächenbeschichtung, d.h. als galvanischer Niederschlag, verarbeitet. Basismaterial von versilberten Bestecken ist Cromargan®. Glanzversilbertes WMF Besteck zeichnet sich durch einen besonders hohen Gebrauchswert, in Verbindung mit dem festlichen Glanz des Silbers aus. Ein Besteck, das täglich benutzt werden kann und das noch nach vielen Jahren sein schönes Aussehen behält.

Eigenschaften

- Metall mit dem höchsten Reflexionsvermögen
- absolut alltagstauglich
- antibakterielle Wirkung

Material:

For cutlery and tableware WMF mainly uses:

High quality steels (Cromargan®, chrome steel) which are resistant to corrosion and acid, whereas Cromargan® is partly finished with silver plating.



Cromargan®

- Cromargan® is the registered trademark of WMF for special stainless steel 18/10
- Cromargan® has registered in 1927 as a trademark of WMF
- WMF uses Cromargan® for the production of cutlery, cookware and a lot of other products.

Characteristics

- indestructible and easy to clean even when intensively used
- dishwasher safe
- resistant to temperature changes
- tasteless and resistant to all food acids
- completely hygienic

Chrome steel

The chrome steel used by WMF shows a very high resistance to food acids as well as to intensive use of dishwashers. This material is used for high quality knife blades.

Silver

Silver is being used as surface coating, i.e. as a galvanic precipitate for hotel products.

Cromargan® is the basic material of silver plated cutlery. Polished silver plated WMF cutlery is characterized by a very high level of use in relation to the brilliance of the silver. A cutlery which can be used daily and keeps its beautiful look even after many years.

Characteristics

- metal with the highest level of reflection
- completely suitable for daily use
- antibacterial effect

Material
material

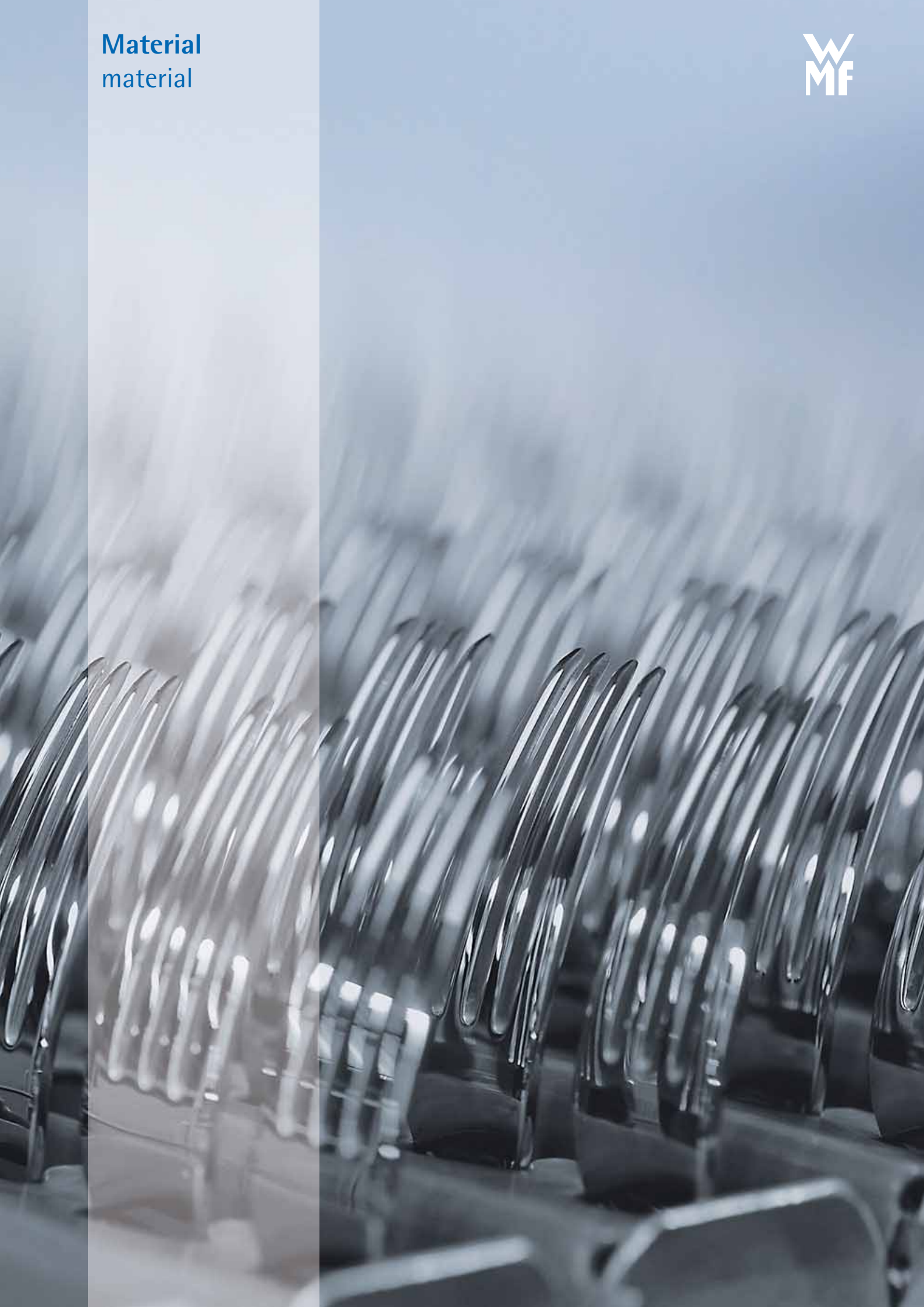



Aufarbeitung & Reparatur

Aus alt mach neu - WMF Hotel ist nicht nur ein Anbieter qualitativ hochwertigster Produkte für den gedeckten Tisch und das Buffet, sondern bietet Ihnen auch den einzigartigen Service Ihre Produkte zu reparieren und aufzufrischen.

Nutzen Sie unser Know-how.

Unser Service-Team berät Sie gerne und erstellt Ihnen ein unverbindliches Angebot für folgende Service-Leistungen:

- Oberflächenbearbeitung von Serviergeräten und Bestecken: Polieren, Mattieren oder Sandstrahlen.
- Schweißen und Löten von z.B. Griffen und Scharnieren.
- Komplette Neuversilberung von Tablett, Kannen, Leuchter, etc.
- Ver- und Bearbeitung von Edelstahl, Messing, Neusilber, etc.
- Galvanikverfahren: Versilberung, Vergoldung, Verkupfern, Vernickeln, Verchromen.
- Erneuerung Wellenschliff bei Messern.
- Laserkennzeichnung / Stempelung / Gravuren sowie Ätzung von Bestecken und Serviergeräten.

Bitte wenden Sie sich bei Bedarf an Ihren zuständigen WMF Verkaufsberater oder nehmen Sie direkt Kontakt auf zu unserem Service-Team unter info@WMF-Hotel.de

Refurbishment & Repair

Make new from old – WMF Hotel is not only a supplier of high-class quality products for the table and the buffet but also offers an unique service to repair and polish up your products.

Take advantage of our know-how.

Our service team likes to advise you submits to you an offer without commitment for the following services:

- Processing of the surface of serving dishes and cutlery: Polishing, mat finishing or sandblasting.
- Welding and soldering of handles and hinges for example.
- Complete new silvering of serving trays, pots, candelabras, etc.
- Machining and processing of high quality steel, brass, new silver, etc.
- Electroplating process: silver, gold, copper, nickel and chromium plating.
- Renewal of serrated knives.
- Labelling with laser / stamping / engraving as well as etching of cutlery and service dishes.

For any requirements please apply to your responsible WMF sales agent or contact us directly under info@WMF-Hotel.de

**Aufarbeitung
& Reparatur**
refurbishment &
repair





Pflege-Tipps

Ein gutes Besteck kann Sie über lange Zeit erfreuen. Dafür verdient es auch ein wenig Zuwendung und Pflege, damit eingetrocknete Speisereste, Feuchtigkeit oder falsches Handling diesem nicht dauerhaft Schaden. Alle WMF Bestecke in der original WMF Legierung Cromargan® sind spülmaschinenfest. Damit Ihr Besteck immer so schön bleibt wie am ersten Tag, hier einige Pflegetipps:

- Reinigen Sie Ihr Besteck nach Gebrauch von groben Speiseresten und lassen Sie es nie längere Zeit ungespült liegen.
- Besteck darf nicht eingeweicht werden oder längere Zeit feucht liegen bleiben.
- Beim Waschen in der Spülmaschine stellen Sie die Besteckteile mit dem Griff nach unten in den Korb. Sie vermeiden Kratzer, indem Sie Bestecke unterschiedlicher Art getrennt voneinander spülen.
- Nehmen Sie Ihr Besteck möglichst bald nach Beendigung des Spülgangs aus der Maschine und trocknen Sie es bei Bedarf ab. Falls dies nicht möglich ist, öffnen Sie bitte die Tür der Maschine, damit der Dampf abziehen kann und kein Feuchtigkeitsstau entsteht.
- Wir empfehlen, nach dem Auffüllen Ihrer Spülmaschine mit Regeneriersalz einen Leerspülgang durchzuführen.
- Verwenden Sie nur hochwertige Geschirrspülmittel, und beachten Sie die Hinweise auf den Packungen der Spülmittel, damit Sie stets mit einem glänzenden Ergebnis rechnen können. Beachten Sie auch die Gebrauchsanleitung Ihrer Geschirrspülmaschine.

Für Bestecke mit perfekter Glanzversilberung gelten folgende Pflegehinweise:

Sie sind spülmaschinenfest und im täglichen Gebrauch unkompliziert. Falls Ihr Silberbesteck längere Zeit nicht benutzt wurde, empfehlen wir das WMF Purargan® Silberpflegemittel.

Maintenance

A good cutlery can please you for a long time. For this reason it deserves a little attention and care so that dried up leftovers, humidity and wrong handling causes durable damage.

All WMF cutlery models in the original WMF alloy Cromargan® are dishwasher safe. For keeping your cutlery as beautiful as on the first day, please see the following care hints:

- After use please clean your cutlery of rough leftovers and do not leave it uncleaned for any length of time.
- Cutlery must not be soaked or left damply for any length of time.
- When cleaning in the dishwasher please put the cutlery items with the handle on bottom in the basket. You avoid scratches when cleaning cutleries of different types separately.
- Take your cutlery out of the dishwasher as soon as possible after ending of the cleaning process and dry it if necessary. If this is not possible please open the door of the dishwasher so that the damp can move off and no humidity accumulation can occur.
- We recommend making a cleaning process with the empty dishwasher first after refilling the regenerating salt.
- Use only high quality cleaning products and pay attention to the advices on the packages of the washing-up liquids so that you can always expect a brilliant result. Pay also attention to the operation instructions of your dishwasher.

For cutlery with perfect polished silver plating the following care advices are valid:

They are dishwasher safe and uncomplicated in daily use. If the silver cutlery is not being used for any length of time we recommend the WMF Purargan® silver care product.

Pflege-Tipps
maintenance





Purargan® Silbertauchbad

Purargan®-silver-dip-bath
 Purargan®-bain à immersion pour l'argenterie
 Purargan®-baño de inmersión limpiaplata
 Purargan®-bagno ad immersione per la pulizia dell'argento

Zur regelmäßigen Behandlung versilberter Teile mit leichtem bis mittleren Anlauf. /
 For regular care of silverplated items with slight to medium tarnish.

Inhalt	cap.	
Ltr.	oz.	
5	175	14.2826.9990



Purargan® C, -Pflegemittel für Silber, Messing und Kupfer

Purargan® C, -silver, brass and copper polish
 Purargan® C, -produit de nettoyage pour l'argenterie, laiton et cuivre
 Purargan® C, -limpia-plata, latón y cobre
 Purargan® C, -liquido per la pulizia dell'argento

geeignet für starken Anlauf und gleichzeitiges Aufpolieren der Oberfläche der Produkte /
 suitable for heavy tarnish and also for polishing the surface of the products

Inhalt	cap.	
Ltr.	oz.	
1	35	14.2828.9990



Purargan® forte, -Pflegemittel für Silber, Messing und Kupfer

Purargan® forte, -silver, brass and copper polish
 Purargan® forte, -produit de nettoyage pour l'argenterie, laiton et cuivre
 Purargan® forte, -limpia-plata, latón y cobre
 Purargan® forte, liquido per la pulizia dell'argento

geeignet für leichten bis mäßigen Anlauf, enthält Wiederanlauf-Schutz /
 suitable for slight to moderate tarnish; contains anti-tarnish protection

Inhalt	cap.	
Ltr.	oz.	
1	35	14.2831.9990



Purargan®-Silber-Pflegetuch

Purargan®-silver polishing cloth
 Purargan®-chiffon nettoyeur pour argenterie
 Purargan®-pañó de limpieza para platería
 Purargan®-panno per la cura dell'argento

Reinigt und schützt durch Polieren vor Anlauf von Silber, Kupfer, Messing und Zinn. /

Cleans and polishes to protect silver, copper, brass and tin from tarnishing.

14.2822.9990

Artikel	Seite	Artikel	Seite	Artikel	Seite
"4 for you" - Löffel	62	Eierbecher- / Teelicht-Aufsatz	71	Kartenhalter	133 - 134
Abdeckhaube	154, 231	Eierbecher-Set	115	Kartoffellöffel	57
Adapter für Elektroheizteil	196	Eier-Einsatz	193	Kaviar-Bowl	109
Allround "KaffeeKultur-Set"	67	Eierlöffel	58, 115	Kaviarkühler	109
Ascher	252	Einsatz für Chafing Dish	192	Kaviarlöffel	61
Austerngestell	109	Einsteckschild	159	Kaviarmesser	61
Austernplatte	108	Einzelartikel "KaffeeKultur"	68	Kellnermesser	250
Bargestell	247	Eisgefäß	251 - 252	Kinderstet	64
Barlöffel	248	Eislöffel XL	63	Korkenzieher	251
Barmesser	249	Eisröhre	215	Krümelsammler	116
Barquirl	249	Eisschale	110, 120, 241	Kuchen-/Tortenplatte	232
Barzange	249	Eisschaufel	57	Kühlakku	155
Bebildungs-Satz	164	Eiswanne	154 - 155	Kühlbehälter	161, 222
Beilagenschale	159	Eiswasserkrug	97 - 98	Käsedose	142
Besteckablage	198 - 199	Eiszange	54, 247	Käseglocke	231
Besteckbaum	162	Erweiterungsreling L	146	Käsemesser	62
Bitterflasche	245	Erweiterungsreling M	147	Lachs Brett	230
Blumenvase	128 - 130	Espresso-Set	66	Latte Macchiato-Set	66, 88
Boston Shaker	244	Essig-/Ölflasche	137	Légumier	101 - 102
Bowlenlöffel	56	Essig-/Ölgestell	136, 138 - 139, 141	Leuchter	122 - 124
Bratenplatte	103	Essig-/Öl-Menage	138	Löffel "KaffeeKultur"	62
Brennstoffdose	198	Essig-/Öl-Set	137	Marmeladegestell	113
Brennstoffdosenhalter	197 - 198	Etagère	160, 219 - 221	Menage	107, 141
Brennstoffdosen-Regulierer	198	Fischservierbesteck	61	Messbecher	244 - 245
Brennstoffhalter Coffee Urn	202	Flaschenteller	96	Milchdispenser	213 - 214
Brille	156, 158	Fleischgabel	52	Milchkaffee-Set	66
Brotkorb	118, 239	Früchtekorb	118, 121, 161, 223, 239, 242	Milchkanne	73 - 76
Brotmesser	58	Gastronorm-Einsatz	194	Milchkännchen	86
Brottschale	119, 240	Gebäck- und Servierzange	54	Milch-Zucker-Set	80 - 81, 83 - 85
Buffetgestell	176 - 178	Glas S	238	Mokkaétagère	111, 220
Buffetkegel-Schiene	237	Glasbehälter	71	Nudellöffel	53
Buffet-Kegel-Set	236	Glaskrug	156	Obstschale	120 - 121, 241 - 242
Buffet-Set	216 - 217	Glasschale	157 - 158, 160, 221	Parmesanreibe mit Behälter	53
Butterkühler	104 - 105	Glasschüssel für Punchbowl	92	Petits Fours-Ständer	112 - 113
Café au Lait-Set	67	Glas-Set LATTE	88	Plastik-Tischnummer	132
Café Crème-Set	66	Gläser-/Flaschenring	92 - 93	Platte	152, 193
Ceralien-/Saft-Set	216	Gläser-Set	88	Platzteller	99
Cerealien-Dispenser	206 - 207	Gläsersteller	96	Plexiglashülle S	163
Chafing Dish	147 - 148, 174 - 175, 182 - 187	Grundreling L	146	Portions-Chafing Dish	186
Chafing Dish - Besteck	52, 200	Grundreling M	146	Portionsschöpfer	57
Chillcup	110	Happy Spoon	61, 237	Porzellanbehälter	70
Cocktail- und Dessertschale	120, 241	Happy Spoon Gestell	106, 238	Porzellan-Einsatz	189, 192, 195
Cocktailshaker	244	Heizelement	149, 196 - 197	Porzellan-Einsätze	193
Cocktailsieb	245	Heizelement Coffee Urn	202	Porzellankugel	157, 159
Coffee Urn	201 - 202	Honig-/Sahnespender	79	Porzellanschale	87, 113
Deckel mit Ausschnitt	69	Hummergabel	55	Porzellantasse S	238
Deckel zu Glasschale	157, 160, 221	Hummerzange	55	Punchbowl	91 - 92
Deckel zu Zuckerdose	74, 77	Hygieneschutz	162	Purargan® C	276
Dekorations-Picker	236	Isolierkanne	77	Purargan® forte	276
Dekorierzange	248	Kaffeebereiter	72	Purargan® Silbertauchbad	276
Dessertgestell	106 - 108, 217 - 219	Kaffeekanne	72 - 74, 76 - 77	Purargan®-Silber-Pflegetch	276
Doppel-Espresso-Set	67	Kaffeetablett	87, 225	Rahmen	149 - 150
Dosenöffner	250	Kapselheber	249	Relish-Pickles-Gestell	246
Dressingbehälter	159			Ring für Glasschüssel	92
Dressinglöffel	56			Roheisschaufel	248
Eierbecher / Teelicht	126			Rotweinwiege	91
Eierbecher / Teelicht / Vase	71, 115, 127, 129			Rührglas	244

Artikel	Seite	Artikel	Seite
Saftbar	215	Universalschale	103 - 104, 119, 240, 246
Saftdispenser	212 - 213	Universalteller	103
Sahne-/Zucker-Set	69	Universalzange	54
Sahnegießer	78	Wandhalterung Cer.disp.	208
Sahnekännchen	70	Wein-/Sektkühler	93 - 94
Sahne-Zucker-Set	81 - 82	Weinkorb	91
Salat-/Vorlegebesteck	52	Weinkühler	94 - 95
Salatzange	53	Weinkühlerständer	95 - 96
Salz- und Pfeffergestell	136	Windlicht	124 - 126
Salz-/Pfeffer-Set	140	Vorlege-/ Aufschnittgabel	58
Salzmühle / Pfeffermühle	135	Zahnstocher- und Süßstoffbehälter	86, 117, 134, 141
Salzstreuer / Pfefferstreuer	135	Zahnstocherbehälter	116 - 117
Sauceneinsatz	193	Zigarrenabschneider	253
Saucenlöffel	56	Zitronenpresse	90, 251
Sauciere	101	Zuckerdose	74 - 76, 85 - 86
Schild mit Kette	203	Zuckerdosierer	79
Schnecken-gabel	55	Zucker-gestell	79, 83
Schnecken-zange	56	Zuckerstangengefäß	86
Schreibtafel S	162	Zuckerteller	78
Sektflaschenverschluss	247	Zuckerzange	55, 250
Senftopf	142		
Serviergestell	108, 219		
Servierpfanne / Paella Pfanne	103		
Serviertablett für Zucker	80		
Spangen für Gläser	237		
Speisekartenhalter	134		
Spritzkork	245		
Steakbesteck	60		
Steakbesteck SOLID	60		
Steakmesser	60		
Steakmesser*	60		
Stößel	250		
Suppenmarmite	189, 191		
Suppenschöpfer	57		
Suppenstation	190		
Suppenterrine	102		
Tablett	87, 114, 137, 152 - 153, 161, 222, 224 - 230		
Tablett Gastronorm	228 - 229		
Teeglas	89		
Teekanne	72 - 73, 75 - 76, 78		
Teelichtleuchter 3fl. klein	126		
Teesieb	72, 89		
Teesieb-Behälter	73, 89		
Teesieb-Einsatz	89		
Teller-/Schalengestell	217		
Teller-cloche	99 - 100		
Tischnummer	131		
Tischnummern-Aufsteller	133		
Tischnummernständer	131 - 133		
Tischrestehälter	116		
Toastständer	114		
Tortenheber	62		
Tortenplatte	160, 222, 232		
Tortenständer	220		
Tranchierbrett	190		
Tranchiergabel	59		
Tranchiermesser	59		
Transportgestell	215		
Tropfblech	155		

Article	Page	Article	Page	Article	Page
"4 for you" spoon	62	creamer	70, 78, 86	ice tube	215
4-pc. child's set	64	cutting board	190	ice-shovel	57
all purpose dish	103	decoration tongs	248	insert for boiled eggs	193
all-round "KaffeeKultur Set"	67	dessert stand	106 - 108, 217 - 219	insert for chafing dish	192
ash tray	252	drainer	155	insert holder	156, 158
bar knife	249	dressing insert	159	jam stand	113
bar spoon	248	dressing ladle	56	jigger	244 - 245
bar tongs	249	egg cup / tealight	126	juice bar	215
bar-relish dish	247	egg cup / tealight / vase	71, 115, 127, 129	juice dispenser	212 - 213
basic rail L	146	egg cup / tealight insert	71	Latte Macchiato Set	66, 88
basic rail M	146	egg cup set	115	lemon/orange squeezer	90, 251
bitter bottle	245	egg spoon	58, 115	lid for glass bowl	157, 160, 221
blackboard S	162	espresso double set	67	lid for sugar basin	74, 77
boston shaker	244	espresso set	66	lid with cut-out	69
bottle opener	249	etagere	160, 219 - 221	lobster fork	55
bowl for bread	118 - 119, 239 - 240	extension rail L	146	lobster-crack	55
bowl for ingredients	159	extension rail M	147	meat fork	59
bread knife	58	finger bowl	104, 119, 240, 246	meat platter	103
bread-basket	118, 239	fish servers	61	menage	107, 141
buffet cone set	236	flower vase	128 - 130	menu stand	134
buffet set	216 - 217	frame	149 - 150, 176 - 178	milk dispenser	213 - 214
burner holder	197 - 198	fruit basket	118, 121, 161, 223, 239, 242	milk jug	73 - 76
burner holder coffee urn	202	fruit bowl	120 - 121, 241 - 242	mixing glass	244
butter cooler	104 - 105	fruit stand	120, 241	mustard pot	142
café au lait set	67	glass bowl	157 - 158, 160, 221	name plate with chain	203
café crème set	66	glass dish	71	oil and vinegar set	136 - 139, 141
caffè Latte set	66	glass hooks	237	oil/vinegar bottle	137
cake plate	160, 222, 232	glass insert for punch bowl	92	oyster platter	108
cake stand	220	glass pitcher	156	oyster rack	109
can opener	250	glass ring	92 - 93	pàella pan	103
candelabra	122	glass S	238	parmesan grater	
candle stick	123 - 124	glass set	88	with storage box	53
card holder	133 - 134	glass set LATTE	88	parmesan jar	142
carving knife	59	GN insert	194	pasta serving spoon	53
caviar cooler	109	GN porcelain insert	195	pastry serving tongs	54
caviar knife	61	gravy boat	101	pastry stand	111, 220
caviar spoon	61	gravy ladle	56	petits-fours-stand	112 - 113
cereal dispenser	206 - 207	happy spoon	61, 237	pie server	62
Chafing Dish	147 - 148, 174 - 175, 182 - 187	Happy Spoon stand	106, 238	plastic table number	132
chafing dish serving set	52, 200	heating element	149, 196 - 197, 202	plate and bowl stand	217
champagne bottle sealer	247	holder for heating element	196	plate cover	99 - 100
cheese dish	231	honey/cream dispenser	79	plate tray	99
cheese knife	62	hygienic cover	162	platter	152, 193
chillcup	110	ice bucket	251 - 252	platter Gastronom	152
cigar cutter	253	ice cream bowl	110	plexi glass frame S	163
coaster for bottles	96	ice cream cup	120, 241	porcelain bowl	157, 159
coaster for glasses	96	ice shovel	248	porcelain bowl 3-section	87, 113
cocktail and dessert dish	120, 241	ice spoon XL	63	porcelain cup S	238
cocktail shaker	244	ice tongs	54, 247	porcelain dish	70
cocktail sticks	236	ice tray	154 - 155	porcelain insert	189, 192 - 193
cocktail strainer	245			potato spoon	57
coffee pot	72 - 74, 76 - 77			punch bowl	91 - 92
coffee pot insulated	77			punch bowl ladle	56
coffee press	72			Purargan® C	276
coffee urn	201 - 202			Purargan® forte	276
cooler	161, 222			Purargan®-silver	
cooling block	155			polishing cloth	276
cork-screw	251			Purargan®-silver-dip-bath	276
cover for trays	154, 231				

Article	Page	Article	Page
rack for utensils	198 - 199	tealight candle stick	126
red wine cradle	91	toast rack	114
relish or condiment server	246	toothpick- and sweetener box-holder	86, 117, 134, 141
ring for glass insert	92	toothpick-holder	116 - 117
salad serving tongs	53	transport unit	215
salad/buffet serving set	52	tray	137, 226
salmon board	230	twirling stick	249
salt and pepper set	140	universal dish	103, 119, 240, 246
salt mill / pepper mill	135	utensil holder	162
salt shaker / pepper shaker	135	waiter's knife	250
salt-pepper-set	136	wall mount for cer. disp.	208
sauce insert	193	water pitcher	97 - 98
service tray	161, 222	vegetable dish and cover	101 - 102
serving fork	52, 58	wine / champagne cooler	93 - 94
serving stand	108, 219	wine cooler	95
serving tray	87, 114, 152 - 153, 224 - 230	wine-basket	91
serving tray Gastronorm	228 - 229		
set for cereal/juice dispenser	216		
set of illustrations	164		
sign	159		
silent waiter	116		
single items "KaffeeKultur"	68		
slotted rail for buffet cones	237		
small plate for packed sugar	78		
snail fork	55		
snail tweezer	56		
solid alcohol	198		
soup ladle	57		
soup tureen	102, 189 - 191		
spoons "KaffeeKultur"	62		
squirt-cork	245		
stand for wine/champagne cooler	95 - 96		
steak flatware	60		
steak fork and knife SOLID	60		
steak knife	60		
steak knife*	60		
sterno control	198		
sugar and creamer set	80 - 82		
sugar and milk set	69, 82 - 85		
sugar basin	74 - 76, 85 - 86		
sugar bowl serving tray	80		
sugar dispenser	79		
sugar pack holder	86		
sugar server	79		
sugar set	83		
sugar tongs	55, 250		
table crumbler	116		
table lamp	125 - 126		
table lamp with glass	124 - 125		
table number	131, 133		
table number stand	131 - 133		
tamping tool	250		
tea glass	89		
tea pot	72 - 73, 75 - 76, 78		
tea strainer	72, 89		
tea strainer holder	73, 89		
tea strainer insert	89		

Article	Page	Article	Page	Article	Page
adaptateur pour plaque électrique	196	couteau à fromage	62	intérieur verre pour bol à punch	92
agitateur pour verre	244	couteau à pain	58	kit café au lait	66 - 67
agrafes pour verres	237	couteau à sommelier	250	kit café crème	66
alcool solidifié	198	couteau à steak	60	kit espresso	66
anneau (porte verre)	92 - 93	couteau à steak*	60	kit espresso double	67
anneau pour intérieur verre	92	couteau à viande	59	"kit KaffeeKultur"	
articles isolés "KaffeeKultur"	68	couteau de bar	249	polyvalent	67
assiette de présentation	99	couvercle avec découpe	69	kit latte-macchiato	66
		couvercle pour bol à verre	157		
bac réfrigérant	154 - 155	couvercle pour coupe en verre	160, 221		
bar à jus de fruit	215	couvercle pour sucrier	74, 77	latte-macchiato-set	88
bati	176 - 178	couvert à salade/servir	52	légumier et couvercle	101 - 102
boîte de table	116	couvert à servir le poisson	61	louche	57
bol à punch	91 - 92	couvert à steak	60	louche à potage	57
bol à verre	157 - 158	couvert à steak SOLID	60		
bol de acero	159	couvert enfant	64	marmite à potage	189 - 191
bouchon à champagne	247	crémier	70, 78	menagère	107, 141
bouchon-verseur	245	cuiller "4 for you"	62	menagère 2 pièces	136
boule porcelaine	157, 159	cuiller à caviar	61	mesure	244 - 245
brique réfrigérante	155	cuiller à glace	57	mise à coquetier / bougie	71
broc en verre	156	cuiller à glace XL	63	moulin à sel / moulin à poivre	135
brochettes cocktail	236	cuiller à oeuf	58, 115	moutardier	142
burette à vinaigre/huile	137	cuiller à pommes de terre	57		
		cuiller à punch	56	numéro de table	131, 133
cadre	149 - 150	cuiller à sauce	56	numéro de table en plastique	132
cafetière	72 - 74, 76 - 77	cuiller à soda	248	numéro de table en plastique "Non Smoking"	132
cafetière à piston	72	cuillère à spaghetti	53		
cafetière thermos	77	cuillère de bar	249	ouvre-boîte	250
carafe à l'eau	97	cuillers "KaffeeKultur"	62		
carafe à l'eau	97 - 98	décapsuleur	249	panier à fruits	118, 161, 223, 239
cartouches de combustible - régulatantes	198	dessous de bouteille	96	panier à pain	118 - 119, 239 - 240
cendrier	252	dessous de verre	96	panier à vin	91
Chafing Dish	147 - 148, 174 - 175, 182 - 187	dispenseur de céréales	206 - 207	passoire	89
		dispenseur de jus	212 - 213	passoire à cocktail bar	245
chandelier	122 - 124	dispenseur de lait	213 - 214	passoire à thé	72, 89
chandelier avec verrine	124 - 126	distributeur à miel / crème	79	pelle à gâteau	62
chandelier bougie		double fixation murale		pelle à glace	248
à chauffe-plat	126	p. disp. à céréales	208	pichet à eau froide	
châssis de transport	215	égouttoir	155	double paroi	98
chillcup	110	ensemble buffet	216 - 217	pilon	250
cloche à fromage	231	étagère	160, 219 - 221	pince à décorer	248
cloche pour assiette	99 - 100	étagère à couverts	162	pince à escargots	56
cloche pour plateaux	154, 231	étiquette avec chaîne	203	pince à gâteau	54
coffee urn	201 - 202	étiquette enfichables	159	pince à glace	54, 247
coquetier / bougie				pince à homard	55
à chauffe-plat	71, 115, 126 - 127, 129	flacon à angostura	245	pince à salade	53
		fourchette à escargots	55	pince à sucre	55, 250
corbeille de fruits	121, 242	fourchette à homard	55	pince de bar	249
coupe à cocktail et dessert	120, 241	fourchette à viande	52, 58 - 59	planche à découper	190
coupe à fruits	120 - 121, 241 - 242	fromagère	142	planche à saumon	230
coupe à glace	110, 120, 241			planche Gastronorm	
coupe à sucre	78	garniture pour saucière	159, 193	pour recipient	152
coupe en porcelaine 3 parties	87, 113	GN intérieur	194	planche pour recipient	152
coupe réfrigérante	161, 222	GN intérieur en intérieur	195	plaque électrique	149, 196 - 197, 202
coupe universelle	103 - 104, 119, 240, 246	happy spoon	61, 237	plat	103, 193
coupe verre glasskin	160, 221	huilier-vinaigrier	136 - 141	plat à fruits de mer	108
coupe-cigares	253			plat à pâëlla	103
couteau à caviar	61	intérieur en porcelaine	189, 192 - 193	plat à tarte	160, 222, 232
		intérieur pour chafing dish	192	plat universel	103
				plateau	137, 226

Article	Page	Article	Page
plateau de service	87, 114, 152 - 153, 161, 222, 224 - 230	soucoupe pour passoire à thé	73, 89
plateau de service Gastronorm	228 - 229	soupière	102
plateau de service pour sucre	80	sucrier	74 - 76, 85 - 86
plateau pléxiglas	162	support	156, 158
plateau pléxiglas S	163	support 3 barres de base L	146
porte brûleur	197 - 198	support 3 barres de base M	146
porte brûleur coffee urns	202	support 3 barres supplémentaire L	146
porte menu	134	support 3 barres supplémentaire M	147
porte numéro de table	131 - 133	support couverts à servir	198 - 199
porte petits fours	111 - 113, 220	support plateau fruits de mer	109
porte tarte	220	support pour bols à céréales	217
porte-bouteille	91	support pour confiture	113
porte-carte	133 - 134	support pour pain grillé	114
porte-coupelle pour sets cône de table	237	support pour seau à champagne	95 - 96
porte-cure-dents	116 - 117	tableau S	162
porte-cure-dents et récipient pour sucrètes	86, 117, 134, 141	tasse en porcelaine S	238
pot à lait	73 - 76	théière	72 - 73, 75 - 76, 78
présentoir à assiette	108, 219	tire-bouchon	251
présentoir a cereales/jus de fruit	216	tube à glace	215
présentoir à gâteau	106 - 108, 217 - 219	vase à fleurs	128 - 130
présentoir Happy Spoon	106, 238	verre à thé	89
presse-citron	90, 251	verre S	238
Purargan® C	276		
Purargan® forte	276		
Purargan®-bain à immersion pour l'argenterie	276		
Purargan®-chiffon nettoyeur pour argenterie	276		
ramasse-brosse	116		
râpe à parmesan avec boîte fraicheur	53		
récipient en porcelaine	70		
récipient en verre	71		
récipient pour oeufs à la coque	193		
refraîchisseur à beurre	104 - 105		
refraîchisseur à caviar	109		
saucière	101		
saupoudreuse à sucre	79		
seau à glace	251 - 252		
seau à vin	95		
seau à vin / champagne	93 - 94		
série d'illustrations	164		
service à relish	246 - 247		
service à sucre	79		
service à sucriers	83		
service pots à lait / sucriers	69, 80 - 86		
service pour chafing dish	52, 200		
set à glass	88		
set à glass LATTE	88		
set cône de buffet	236		
set de coquetier	115		
shaker	244		
shaker boston	244		
simple fixation murale pour disp. à céréales	208		

Articulo	Página	Articulo	Página	Articulo	Página
abrebottellas	249	cubierto steak	60	jarra agua	97 - 98
abrelatas	250	cubierto steak SOLID	60	jarra de cristal	156
abridor múltiple-camareros	250	cubiertos para chafing dish	200	juego azucarero	83
acumulador refrigerador	155	cubo hielo	251 - 252	juego azucarero / cremera	69,
adaptador para placa		cubo vino	95		80 - 85
calentadora	196	cubo vino / champán	93 - 94	juego café con leche	66 - 67
anilla para interior de cristal	92	cuchara "4 for you"	62	juego café-crème	66
anilla para ponchera	92 - 93	cuchara bar	248	juego de bufete	216 - 217
		cuchara caviar	61	juego de ilustración	164
árbol cubertero	162	cuchara gitador bar	248	juego espresso	66
artículos diversos		cuchara huevos	58, 115	juego espresso doble	67
"KaffeeKultur"	68	cuchara pasta	53	juego latte macchiato	66, 88
azucarero	74 - 76,	cucharas "KaffeeKultur"	62	juego universal para el	
85 - 86		cucharon patatas	57	"KaffeeKultur"	67
azucarero para azúcar		cuchillo bar	249	juego vasos	88
en cañas	86	cuchillo carne	59	juego vasos LATTE	88
		cuchillo caviar	61		
bajoplato	99	cuchillo pan	58	lechera	73 - 76
bandeja	87, 114,	cuchillo queso	62	legumbreira con tapa	101 - 102
	137,	cuchillo steak	60	linterna con cristal	124 - 126
	152 - 153,	cuchillo steak*	60		
	161, 222,	cuenco de porcelana		marco	149 - 150
	224 - 230	3 divisiones	87, 113	marco de metacrilato S	163
bandeja con azucareros	80			mazo de mortero	250
bandeja Gastronorm	228 - 229	depósito para chafing dish	192	medidor	244 - 245
bandeja para hielo	154 - 155	depósitos de cristal	157 - 158,	molinillo sal / molinillo	
bastidor de transporte	215		160, 221	pimienta	135
batidor de bar	249	dispensador de cereales	206 - 207	mostacero	142
bol de acero	159	dispensador de zumo	212 - 213		
bola de porcelana	157, 159	dispensador leche	213 - 214	número de mesa	131, 133
botella de aceite/vinagre	137	dispensador miel / nata	79	número de mesa plastico	132
botella para bitter	245	dosificador azúcar	79	número de mesa plastico	
				"Non Smoking"	132
cafetera	72 - 74,	enfriador caviar	109	paellera	103
	76 - 77	enfriador para mantequilla	104 - 105	pala hielo	248
cafetera de émbolo	72	etiqueta con cadena	203	pala para hielo	57
cafetera termo	77	exprimidor para limones	90, 251	pala para hielo XL	63
campana	100			pala tarta	62
campana con pomo	99	florero	128 - 130	palillero	116 - 117
campana para bandejas	154, 231	frutero	118,	palillero y dispensador de	
candelabro	122		120 - 121,	edulcorante	86, 117,
candelero	123 - 124		161,		134, 141
candelero lamparilla	126		219 - 220,	panera	118 - 119,
cazo ponche	56		223, 239,		239 - 240
cazo porciones	57		241 - 242	pincho de cocktail	236
cazo salsa	56	frutero articulado	160, 221	pinza caracoles	56
cazo sopa	57	fuelle	103, 152,	pinza de azucar	55, 250
cenicero	252		193	pinza hielo	54, 247
cesta de frutas	121, 242	fuelle Gastronorm	152	pinza para decorar	248
cesta del pan	118, 239	fuelle para mariscos	108	pinza para ensalada	53
cesta vino	91			pinza para langostas	55
Chafing Dish	147 - 148,	ganchos para vasos	237	pinza para pasteles	54
	174 - 175,	GN interior	194	pinzas bar	249
	182 - 187	GN interior porcelana	195	pizarra S	162
coctelera	244			placa calentadora	149,
coctelera boston	244	happy spoon	61, 237		196 - 197,
colador de cocktail	245	huevera / candela	71, 115,	place calentadora	197
combustible	198		126 - 127,	platito azúcar	78
copa cóctel mariscos	110		129	plato tarta	160, 222,
copa cóctel y postre	120, 241				232
copa helado	110	interior colador té	72, 89	plato universal	103
cortapuros	253	interior cristal	92	ponchera	91 - 92
cremera	70, 78, 86	interior de porcelana	193	porta aperitivos	246
cubierto ensalada/servir	52	interior para huevos cocidos	193	porta menus	134
cubierto niño	64	interior para salsas	193	porta número de mesa	131
cubierto servir chafing dish	52	interior porcelana	189, 192		
cubierto servir pescado	61				

Artículo	Página	Artículo	Página
porta número de mesa (sin grabación)	133	soporte para platos o fuentes	217
porta número de mesa (sin número)	132	soporte plato postre	106 - 108, 217 - 218
porta tarta	220	soporte platos	108, 219
portabotella	96	soporte platos postre	108, 219
portabotellas	91	soporte principal L	146
portacubiertos para cono mediano	237	soporte principal M	146
portacubos champán	95 - 96	soporte quemador	197 - 198
portapastas	111 - 113, 220	soporte quemador urna de café	202
portatarjetas	133 - 134	subo vino / champán	94
portatostadas	114	sujeción doble de pared para disp. Cereales	208
portavasos	96	sujeción sencilla de pared para disp. cereales	208
protector higiénico	162	suplemento para huevera / vela	71
Purargan® C	276	tabla para trinchar	190
Purargan® forte	276	tapa con recorte	69
Purargan®-baño de inmersión		tapa para azucarero	74, 77
limpiaplata	276	tapa para depósitos de cristal	157, 160, 221
Purargan®-pañó de limpieza para platería	276	tapón	245
quesera	231	tapón botellas champán	247
rallador queso	53	taza de porcelana S	238
recipiente	142, 161, 222	tenedor bogavante	55
recipiente colador	89	tenedor caracoles	55
recipiente colador té	73, 89	tenedor carne	52, 58 - 59
recipiente de cristal	71	tetera	72 - 73, 75 - 76, 78
recipiente de porcelana	70, 192	tubo para hielo	215
recipiente desperdicios	116	urna de café	201 - 202
recipiente para salsas	159	vaso mezclador	244
recipiente sopa	189 - 190	vaso S	238
recipiente universal	103 - 104, 119 - 120, 240 - 241, 246	vaso té	89
recogemigas	116	vinagreras	136 - 141
regulador de botes de material combustible	198		
rejilla bandeja goteo	155		
rótulo insertable	159		
sacacorchos	251		
salmonera	230		
salsera	101		
servicio condimento	136		
servicio de azúcar	79		
set 3 recipientes	107, 141		
set cono buffet	236		
set cono buffet completo	236		
set de huevera	115		
set para cereales/jugo	216		
set para zumos	215		
sopera	102		
sopera para chafing dish	191		
soporte	156, 158		
soporte adicional L	146		
soporte adicional M	147		
soporte buffet	176 - 178		
soporte cubiertos servir	198 - 199		
soporte de bar	247		
soporte fuente	109		
soporte Happy Spoon	106, 238		
soporte para mermelada	113		

Articolo	Pagina	Articolo	Pagina	Articolo	Pagina
abriscatole	250	coperchio per zuccheriera	74, 77	ménage per tapenade	107, 141
adattatore per piastra		copertura	162	mestolino salsa	56
riscaldante	196	coppa gelato	110, 120,	miscelatore	249
alcool solido	198		241	misurino	244 - 245
alzata per frutta	120 - 121,	coppa per cocktail e frutta	120, 241	mixer	244
	241 - 242	copripiatto con pomolo	99 - 100		
alzata porta dolci	111 - 113	cremiera	78	numero tavolo	131
alzata portadolci	111, 220	cucchiaini "KaffeeKultur"	62	numero tavolo in plastica	132
anello per bicchieri		cucchiaino "4 for you"	62		
e bottiglie	92 - 93	cucchiaino per bar	248	oliera	136 - 141
anello per interno in vetro	92	cucchiaino per bowl	56		
		cucchiaino per caviale	61	padella per servizio	103
barra per posate sets cono		cucchiaino per patate	57	pala da torta	62
da tavola	237	cucchiaino per uovo	58, 115	paletta per ghiaccio	248
base	161, 222	cucchiaino per gelato	57	pestello	250
bicchiere da tè	89	cucchiaino per gelato XL	63	piastra riscaldante	149,
bicchiere S	238	cucchiaino per pasta	53		196 - 197,
boston shaker	244				202
bowl per punch	91 - 92	deposito por		piattino per zucchero	78
bricchetto per il latte	70	portauova / lumino	71	piatto	152
brocca di vetro	156	dispenser cereali	206 - 207	piatto da torta	160, 222,
brocca per acqua	97 - 98	dispenser latte	213 - 214		232
brocca termica a doppia		dispenser per succhi di frutta	212 - 213	piatto Gastronorm	152
parete	98			piatto multioso	103
		estensione L	146	piatto per ostriche	108
caffettiera	72 - 74,	estensione M	147	piatto segnaposto	99
	76 - 77	etagere	160	pinza per aragoste	55
caffettiera con filtro	72			pinza per bar	249
caffettiera termica	77	fermagli per bicchieri	237	pinza per decorare	248
candeliere	122 - 124	forchetta aragosta	55	pinza per ghiaccio	54, 247
candeliere lumino	126	forchetta da antipasto	52, 58	pinza per lumache	56
caraffa per aceto/olio	137	forchetta per lumache	55	pinza per zucchero	55, 250
carrello da trasporto	215	forchettone	59	pinza servire insalata	53
cavatappi	251	formaggiaria	142	pinza servire per dolci	54
cestino per il pane	118, 239	fornello	197 - 198	pinza universale	54
cestino portavino	91	fornello coffee urn	202	porta formaggio	231
cesto di frutta	121, 242	fruttiera	118, 161,	porta frutta	219 - 221
Chafing Dish	147 - 148,		223, 239	porta Happy Spoon	106, 238
	174 - 175,			porta immagini in plexi S	163
	182 - 187	GN interno	194	porta piattini per dessert	106 - 108,
chillcup	110	GN interno in porcellana	195		217 - 219
ciotola universale	103 - 104,	grattuggia formaggio con		porta posante	198 - 199
	119, 240,	contenitore	53	porta rifiuti per tavolo	116
	246	griglia	155	porta stuzzicadenti	116 - 117
coffee urn	201 - 202			porta stuzzicadenti e	
colino per cocktail	245	happy spoon	61, 237	contenitore per dolcificante	86, 117,
colino per tè	72, 89				134, 141
colino per tè con vaschetta		inserto piatto chafing dish	192	portacarta	133 - 134
raccogliocce	89	inserto uovo	193	portamenu	134
colonna per secchio		interno in porcellana	189,	portapane	118 - 119,
spumante	95 - 96		192 - 193		239 - 240
coltellino per caviale	61	interno in vetro	157 - 160,	portapiatti	108, 219
coltello carne	59		221	portapostate con stuttura	
coltello da bistecca	60	interno in vetro per bowl	92	ad albero	162
coltello da bistecca*	60	interno per salsa	193	portasalatini / olive	246
coltello formaggio	62			porta-toast	114
coltello pane	58	lampa da tavola alta		portatorta	220
coltello per bar	249 - 250	c. paralum	126	portauovo / candela	
contenitore per colino tè	73, 89	lampa da tavola alta		scaldavivande	71, 115,
contenitore per salsa	159	con paralume	124 - 125		126 - 127,
coperchio adatto per vassoio	231	lattiera	73 - 76		129
coperchio adatto per vassoio	154, 231	lavagna S	162	posacenero	252
coperchio con punto aperto		legumiera con coperchio	101 - 102	posate chafing dish	52, 200
per cucchiaino	69	levacapsule	249	posate da bistecca	60
coperchio per coppa in vetro	157			posate da bistecca SOLID	60
coperchio per scodella		macinasale / macinapepe	135	posate servire insalata	52
di vetro	160, 221	menage	136	posate servire pesce	61

Articolo	Pagina	Articolo	Pagina
Purargan® C	276	tappo per spumante	247
Purargan® forte	276	targhetta ad appoggio per numero tavolo	131, 133
Purargan®-bagno ad immersione per la pulizia dell'argento	276	targhetta con aggancio a catenella	203
Purargan®-panno per la cura dell'argento	276	targhetta inseribile	159
raccoglibriciole	116	tavoletta per il ghiaccio	155
ramaiolo	57	tazzina di porcellana S	238
recipiente di porcellana	70	teiera	72 - 73, 75 - 76, 78
recipiente di vetro	71	telaio	149 - 150, 176 - 178
regolatore di combustibile	198	tubo in acciaio	215
rinfrecavino / spumante	94	unità base L	146
rinfresca-burro	104 - 105	unità base M	146
rinfresca-caviale	109	vasca per ghiaccio	154 - 155
rinfrescavino	95	vaso da fiori	128 - 130
rinfrescavino / spumante	93 - 94	vassoietto tripartito	
salsiere	101	portazzucchero	87, 113
secchiello da ghiaccio	251	vassoio	87, 103, 114, 137, 152 - 153, 161, 193, 222, 224 - 230
secchiello da ghiaccio	251 - 252	vassoio Gastronorm	228 - 229
segnatavola	131 - 132	vassoio per salmone	230
senapiera	142	vassoio per zucchero	80
serie di illustrazioni	164	versamiele / versalette	79
set "KaffeeKultur" completo	67	versavino	91
set café au lait	67	versazucchero	79
set café crème	66	zuccheriera	74 - 76, 79, 85 - 86
set café espresso doppio	67	zuppiera	102, 189 - 190
set café latte	66	zuppiera per chafing dish	191
set cono buffet	236		
set da bicchieres	88		
set da bicchieres LATTE	88		
set da café espresso	66		
set girevole per succhi di frutta	215		
set latte-macchiato	66, 88		
set lattiera zuccheriera	69, 80 - 86		
set per bambini	64		
set per bar	247		
set per buffet	216 - 217		
set per cereali/succhi	216		
set portastuzzichini conico per buffet	236		
set portauovo	115		
set zuccheriera	83		
sfera in porcellana	157, 159		
shaker	244		
singolo articolo			
"KaffeeKultur"	68		
sottobicchiere	96		
sottobottiglia	96		
spiedini da cocktail	236		
spremilimone	90, 251		
spruzzamaro	245		
spuntasigari	253		
supporto	156, 158		
supporto per confetture	113		
supporto per dispenser cereali	208		
supporto per dispenser cereali dop.	208		
supporto per piatti e coppe	217		
supporto per piatto ostriche	109		
tagliere	190		
tappo a spruzzo	245		

Showrooms
Sales offices in Germany

Frankfurt
Otto-Volger-Straße 5
65843 Sulzbach
☎ 0 61 96 / 75 00-07
Fax 0 61 96 / 74 88 2
verkaufsbuero.sulzbach@wmf.de

Berlin
Am Borsigturm 15
13507 Berlin
☎ 030 / 496 - 65 11
Fax 030 / 496- 98 06
verkaufsbuero.berlin@wmf.de

Hamburg
Mönckebergstr.13
20095 Hamburg
☎ 0 40 / 23 03 21
Fax 0 40 / 23 68 77 31
verkaufsbuero.hamburg@wmf.de

Tochtergesellschaften
Subsidiaries

WMF Nederland B.V.
Postbus 20604
1001 NP Amsterdam
Netherlands

Showroom:
Gyroscoopweg 82/84
1042 AX Amsterdam
Netherlands
☎ +31 20 480 80 80
Fax +31 20 480 80 70
info@wmf.nl

WMF Belgium S.A.-N.V.
Atomiumsquare
B.P./P.B. 673
1020 Brussel/Bruxelles
Belgium
☎ +32 24 788 41 7
Fax +32 24 722 22 83
business@wmf.be

WMF in Österreich GmbH
Etrichgasse 13,
6020 Innsbruck
Austria
☎ +43 512 33 02 - 0
Fax +43 512 33 02 - 98
gastro@wmf.at

WMF Schweiz AG
Bernstraße 90
8953 Dietikon2
Switzerland
☎ +41 43 322 93 33
Fax +41 43 322 93 99
gastro@wmf.ch

WMF Española, S.A.
Avda. Llano Castellano, 15
28034 Madrid/Spain
☎ +34 91 334 12 15
Fax +34 91 729 32 22
hotel@wmf.es

WMF France S.A.R.L.
13 avenue Nicolas Ledoux
94000 Creteil
France
☎ +33 1 49 80 80 10
Fax +33 1 49 80 70 90
info@wmf.fr

WMF Italia S.p.A
Via della Meccanica, 24
37139 Verona/Italy
☎ +39 045 839 35 11
Fax +39 045 839 35 10
ristorazione@wmf.it

WMF United Kingdom Ltd.
31 Riverside Way
Uxbridge
Middlesex UB8 2YF
United Kingdom
☎ +44 1895 816 100
Fax +44 1895 816 105
sales@wmf.uk.com

WMF Americas Group Inc.
3512 Faith Church Road
Indian Trail, NC 28 28079
☎ +1 704-893-3893
Fax +1 704-893-2198
Hotel@WMFAmericas.com

WMF Japan Corp. K.K.
23-5, Nishishinbashi 3-Chome,
Minato-ku,
Tokyo 105-0003
Japan
☎ +81 3 5408 3301
☎ +81 3 5408 3302 (hotel)
Fax +81 3 5408 3311
info@wmf-japan.co.jp
wmfj@wmf-japan.co.jp

WMF Shanghai Co. Ltd.
1101-1102 International
Capital Plaza
1318 North SiChuan Road
Hongkou District
Shanghai 200086
P.R. China
☎ +86 21 5515 5212
Fax +86 21 5515 5220
info@wmf-china.com

WMF Hotel

Eine Marke der proHeq GmbH
A brand of proHeq GmbH
Carl-Benz-Straße 10
D-75217 Birkenfeld, Germany

☎ +49 (0) 72 31 / 4885 500
Fax +49 (0) 72 31 / 4885 590
info@wmf-hotel.de
www.wmf-hotel.de

3127 #63 8080 9990 Printed in Germany 02.13
Druckfehler und Irrtum für den gesamten Inhalt vorbehalten.
Errors and omissions exempted – applies to the full content.

